

TAS20

Time Interval Analyzer

USER'S MANUAL

Foreword

Thank you for purchasing the YOKOGAWA TA520 Time Interval Analyzer. This User's Manual contains useful information about the precautions, functions, and operating procedures of the instrument. To ensure correct use, please read this manual thoroughly before operation.

Keep this manual in a safe place for quick reference in the event a question arises. The following manual is also provided in addition to this manual.

Manual Name	Manual No.	Description
TA520 GP-IB Interface User's Manual	IM704310-12E	Describes the communication functions of the GP-IB interface.

Notes

The contents of this manual are subject to change without prior notice as a result of continuing improvements to the instrument's performance and functions. The figures given in this manual may differ from the actual screen.

Every effort has been made in the preparation of this manual to ensure the accuracy of its contents. However, should you have any questions or find any errors, please contact your nearest YOKOGAWA dealer as listed on the back cover of this manual.

Copying or reproducing all or any part of the contents of this manual without YOKOGAWA's permission is strictly prohibited.

Trademarks

MS-DOS is a registered trademark of Microsoft Corporation.

Other product names are trademarks or registered trademarks of their respective holders.

Revisions

1st Edition: April 1999

2nd Edition: November 1999

Checking the Contents of the Package

Unpack the box and check the contents before operating the instrument. If some of the contents are not correct or missing or if there is physical damage, contact the dealer from which you purchased them.

Main Unit

Check that the model name and suffix code given on the name plate match those on the order.

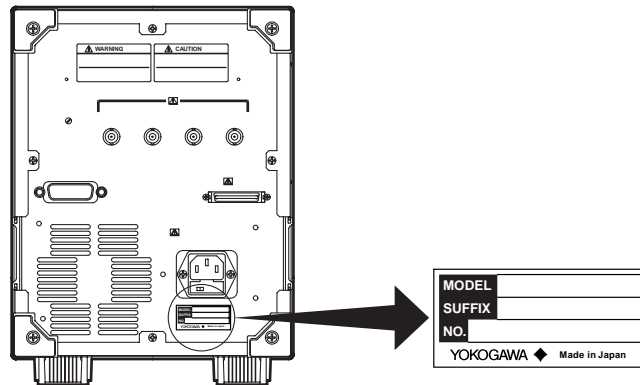

MODEL (Type Name)

704310

SUFFIX (Suffix code)

	Suffix Code	Description
Power voltage	-1	100-120 VAC
	-5	200-240 VAC
Power cord	-D	UL/CSA Standards Power Cord (Part No.: A1006WD) [Maximum Rated Voltage: 125 V, Maximum Rated Current: 7 A]
	-F	VDE Standard Power Cord (Part No.: A1009WD) [Maximum Rated Voltage: 250 V, Maximum Rated Current: 10 A]
	-Q	BS Standard Power Cord (Part No.: A1054WD) [Maximum Rated Voltage: 250 V, Maximum Rated Current: 10 A]
	-R	SAA Standard Power Cord (Part No.: A1024WD) [Maximum Rated Voltage: 240 V, Maximum Rated Current: 10 A]
Optional specifications	/C8	Internal hard disk + SCSI
	/F1	Inter-symbolic interference analysis function

NO. (Instrument No.)

When contacting the dealer from which you purchased the instrument, please quote the instrument No.

Note

We recommend you keep the packing box. The box is useful when you need to transport the instrument.

Standard Accessories

The following standard accessories are supplied with the instrument.

Part Name	Part Number	Quantity	Notes
1. Power cord	See page 2	1	See page 2
2. Rubber feet	A9088ZM	1	A set of two pieces
3. Printer roll chart	B9850NX	1	Thermalsensible paper Total length: 30 m
4. User's Manual	IM 704310-01E	1	User Manual (this manual)
5. User's Manual	IM 704310-12E	1	GP-IB Interface User's Manual
6. Spare fuse for the power supply	A1436EF	1	Spare, attach to fuse holder of the main unit

1. Power cord (one of the following power cords is supplied according to the instrument's suffix codes)

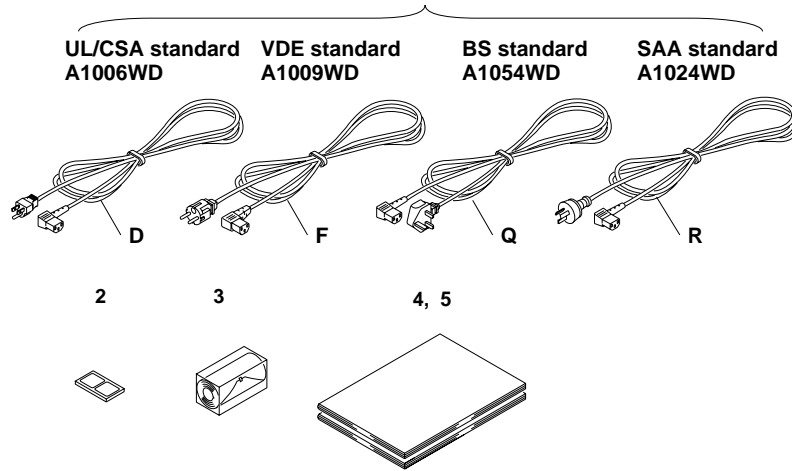

Optional Accessories (sold separately)

The following optional accessories are sold separately.

For information and ordering, contact your dealer.

Part Name	Part No.	Sales Unit	Notes
BNC cable	366924	1	BNC-BNC, Length: 1 m
BNC cable	366925	1	BNC-BNC, Length: 2 m
Rack mount kit	751533-E6	1	For EIA single mount
Rack mount kit	751534-E6	1	For EIA dual mount
Rack mount kit	751533-J6	1	For JIS single mount
Rack mount kit	751534-J6	1	For JIS dual mount

Safety Precautions

This instrument is an IEC safety class I instrument (provided with terminal for protective grounding).

The following general safety precautions must be observed during all phases of operation. If the instrument is used in a manner not specified in this manual, the protection provided by the instrument may be impaired. YOKOGAWA Electric Corporation assumes no liability for the customer's failure to comply with these requirements.

The following symbols are used on this instrument.



"Handle with care." To avoid injury, death of personnel or damage to the instrument, the operator must refer to the explanation in the User's Manual or Service Manual.



Alternating current



ON (power)



OFF (power)



ON (power) state



OFF (power) state

Make sure to comply with the following safety precautions. Not complying might result in injury, death of personnel, or cause damage to the instrument.

WARNING

Power Supply

Ensure that the source voltage matches the voltage of the power supply before turning ON the power.

Power Cord and Plug

To prevent an electric shock or fire, be sure to use the power cord supplied by YOKOGAWA. The main power plug must be plugged into an outlet with a protective grounding terminal. Do not invalidate protection by using an extension cord without protective grounding.

Protective Grounding

Make sure to connect the protective grounding to prevent electric shock before turning ON the power.

Necessity of Protective Grounding

Never cut off the internal or external protective grounding wire or disconnect the wiring of the protective grounding terminal. Doing so poses a potential shock hazard.

Defect of Protective Grounding and Fuse

Do not operate the instrument when the protective grounding or the fuse might be defective. Also, make sure to check them before operation.

Fuse

To avoid fire, only use a fuse that has a rating (voltage, current, and type) that is specified by the instrument. When replacing a fuse, turn OFF the power switch and unplug the power cord. Never short the fuse holder.

Do Not Operate in Explosive Atmosphere

Do not operate the instrument in the presence of flammable liquids or vapors. Operation of any electrical instrument in such an environment constitutes a safety hazard.

Do Not Remove Covers

Some areas inside the instrument have high voltages. Do not remove the cover if the power supply is connected. The cover should be removed by YOKOGAWA's qualified personnel only.

External Connection

Connect the protective grounding before connecting to the item under measurement or control unit.

Structure of the Manual

This User's Manual consists of the following 15 chapters and an index.

Chapter 1 Functions

Describes the measurement principles and functions of the instrument. Operating procedures are not given in this chapter. However, reading this chapter will help you understand the operating procedures given in the chapters that follow.

Chapter 2 Names and Uses of Parts

Describes the names and uses of each part of the instrument. For keys, references are given to sections (or pages) in the manual where operating procedures are explained.

Chapter 3 Before Starting Measurements

Describes precautions on use, how to install the instrument, how to connect the power supply, turn ON/OFF the power switch, connect a probe, and set the date and time.

Chapter 4 Basic Operations

Describes how to start/stop the measurement acquisition of input signals, enter values using the numerical keys, and operate the rotary knob.

Chapter 5 Setting the Sampling Mode and Measurement Functions

Describes how to set the sampling mode and measurement function (item).

Chapter 6 Setting the Acquisition Conditions of the Measurement Input Signal

Describes how to set the acquisition conditions of the measurement input signal such as input coupling, input impedance, trigger mode, trigger level, gate, sampling size, sampling interval, arming source, slope, delay, and inhibit.B

Chapter 7 Displaying the Measured/Calculated Results in the Time Stamp Mode

Describes how to configure the displays such as histograms, time variations, lists, statistics, and panorama.

Chapter 8 Displaying the Measured/Calculated Results in the Hardware Histogram Mode

Describes how to configure the displays such as histograms, lists, statistics, multi-windows, panoramas, and histogram sum.

Chapter 9 Using the Inter-symbolic Interference Analysis Function (Option)

Describes how to use the inter-symbolic interference analysis function.

Chapter 10 Storing/Recalling Setup Information from the Internal Memory

Describes how to store and recall setup information from the internal memory and how to change the setup.

Chapter 11 Saving and Loading Data and Connecting to a PC

Describes how to save and load data such as setup information and measured/calculated results from the floppy disk, internal hard disk (option), and external SCSI devices and how to format disks and delete data.

Chapter 12 Outputting Screen Images

Describes how to output screen images to the internal printer, the floppy disk, the internal hard disk (option), and to an external SCSI device.

Chapter 13 Using Other Functions

Describes how to initialize the settings, calibrate the instrument, output monitor signals, confirm current conditions, adjust the brightness of the LCD, and other such operations.

Chapter 14 Troubleshooting and Maintenance

Describes the possible causes of problems and their appropriate corrective measures. Describes the messages that are displayed on the screen. Describes how to log errors, perform self-tests, adjust the time base, carry out performance tests, and replace fuses.

Chapter 15 Specifications

Describes the specifications of the instrument.

Index

Gives an index.

Conventions Used in this Manual

Unit

k Denotes 1000. Example: 100kHz

K Denotes 1024. Example: 720KB (Storage capacity of floppy disks)

Symbols

The following symbols are used in this manual.



Affixed to the instrument. Indicates danger to personnel or instrument and the operator must refer to the User's Manual. The symbol is used in the User's Manual to indicate the reference.

WARNING

Describes precautions that should be observed to prevent injury or death to the user.

CAUTION

Describes precautions that should be observed to prevent minor or moderate injury, or damage to the instrument.

Note

Provides important information for the proper operation of the instrument.

Symbols used on pages in which operating procedures are given.

In chapters 3 through 13, on pages where operating procedures are given, the following symbols are used to classify a description.

Procedure

Describes the keys used during operation and the operating procedures. In some cases, you may not have to follow the steps in the order they are given.

Explanation

Describes the details of the settings and the restrictions that exist with the operating procedure. A detailed description of the function is not provided in this section. See chapter 1 for a detailed description of the functions.

Contents

Checking the Contents of the Package	ii
Safety Precautions	iv
Structure of the Manual	vi
Conventions Used in this Manual	vii



Chapter 1 Functions

1.1	System Configuration and Block Diagram	1-1
1.2	Measurement Principle	1-3
1.3	Sampling Mode	1-4
1.4	Measurement Functions (Measurement Items)	1-5
	Period, Time Interval, Pulse Width	1-5
1.5	Acquisition Conditions for the Input Signal Being Measured	1-6
	Measurement Block	1-6
	Block Sampling	1-7
	Gate, Sampling Interval	1-8
	Arming, Arming Delay	1-9
	Inhibit	1-10
	Input Coupling, Input Impedance	1-11
	Trigger Mode/Trigger Level, Reference Signal I/O	1-12
1.6	Analysis and Calculation	1-13
	Readout Function	1-13
	Statistical Calculation	1-14
1.7	Displaying the Measured/Calculated Results	1-18
	Histogram Display	1-18
	List Display	1-19
	Time Variation Display	1-20
	Statistics Display	1-21
	Panorama Display	1-22
	Multi-window function	1-23
	Auto window function, Scaling Function	1-24
1.8	Other Functions	1-25
	External Signal Input/Output, Communication, Storing and Recalling Setup Information, Saving and Loading Data from Floppy Disks, the Internal Hard Disk, and External SCSI Devices, Initialization of Setup Information	1-25
	Calibration, Beep and Click Sounds, Error Logging, Self-test, Inter-symbol Interference Analysis Function (Option)	1-26





Chapter 2 Names and Uses of Parts

2.1	Front Panel	2-1
2.2	Rear Panel	2-2
2.3	Screen Display	2-3

Chapter 3 Before Starting Measurements

3.1	Precautions on the Use of the instrument	3-1
	3.2 Installing the Instrument	3-3
	3.3 Connecting the Power Cord	3-5
	3.4 Turning the Power Switch ON/OFF	3-6
	3.5 Connecting Cables and Probes	3-7

△	3.6	Calibrating the Probe (Performing Phase Correction)	3-8	1
	3.7	Setting the Date and Time	3-10	
Chapter 4 Basic Operations				2
	4.1	Starting and Stopping the Acquisition of an Input Signal	4-1	
	4.2	Setting Numerical Values and Strings	4-2	
	4.3	The Way to Look at the Soft Key Menu/Using the Rotary Knob and Select Key	4-4	3
Chapter 5 Setting the Sampling Mode and Measurement Functions				4
	5.1	Selecting the Sampling Mode	5-1	
	5.2	Setting the Period Measurement	5-2	
	5.3	Setting the Time Interval Measurement	5-3	
	5.4	Setting the Pulse Width Measurement	5-5	5
Chapter 6 Setting the Acquisition Conditions of the Measurement Input Signal				6
	6.1	Setting the Gate	6-1	
	6.2	Setting the Sampling Interval	6-4	
	6.3	Performing Block Sampling	6-5	
△	6.4	Setting the Arming Source, Slope, and Delay	6-7	7
△	6.5	Setting the Inhibit Function	6-11	
	6.6	Setting the Input Coupling, Input Impedance, and Trigger	6-13	
△	6.7	Inputting/Outputting the Reference Signal	6-15	8
Chapter 7 Displaying the Measured/Calculated Results in the Time Stamp Mode				9
	7.1	Displaying the Histogram	7-1	
	7.2	Displaying the List	7-3	
	7.3	Displaying the Time Variation	7-5	
	7.4	Displaying the Statistics	7-7	
	7.5	Displaying the Panorama Display	7-9	10
	7.6	Setting the Statistical Calculation Parameters (Calc/Stat)	7-12	
	7.7	Changing the Scale Value	7-15	
	7.8	Reading the Data	7-17	11
Chapter 8 Displaying the Measured/Calculated Results in the Hardware Histogram Mode				12
	8.1	Displaying the Histogram	8-1	
	8.2	Displaying the List	8-3	
	8.3	Displaying the Statistics	8-5	
	8.4	Displaying the Panorama Display	8-7	13
	8.5	Using the Multi-Window Function	8-10	
	8.6	Using the Auto Window Function	8-13	
	8.7	Setting the Statistical Calculation Parameters (Calc/Stat)	8-16	14
	8.8	Changing the Scale Value	8-18	
	8.9	Reading the Data	8-20	
Chapter 9 Using the Inter-symbol Interference Analysis Function (Option)				15
	9.1	Using the Inter-symbol Interference Analysis Function	9-1	
	9.2	Setting the Conditions for Data Extraction	9-3	
	9.3	Analysis Example	9-6	

Chapter 10 Storing/Recalling Setup Information from the Internal Memory	
10.1	Storing the Setup Information to the Internal Memory 10-1
10.2	Recalling Setup Information from the Internal Memory 10-2
Chapter 11 Saving and Loading Data and Connecting to a PC	
11.1	Floppy Disks 11-1
 11.2	Internal Hard Disk (Option) 11-2
11.3	Connecting SCSI Devices 11-3
11.4	Changing the SCSI ID Number 11-4
11.5	Formatting the Disk 11-5
11.6	Saving and Loading Setup Information 11-8
11.7	Saving and Loading the Measurement Results 11-12
11.8	Saving the Statistical Calculation Results 11-16
11.9	Deleting Files 11-18
11.10	Copying Files 11-21
11.11	Changing the File Name and Creating Directories 11-24
11.12	Connecting the Instrument to a PC 11-26
Chapter 12 Outputting Screen Images	
12.1	Attaching the Paper Roll for Printing 12-1
12.2	Printing 12-4
12.3	Saving Screen Images to Floppy Disk, Internal Hard Disk (Option), and External SCSI Device 12-6
Chapter 13 Using Other Functions	
13.1	Initializing the Setup Information 13-1
13.2	Calibrating the Instrument 13-4
 13.3	Outputting Monitor Signals 13-5
13.4	Checking the Setup Conditions of the Instrument and the ROM Version 13-6
13.5	Turning ON/OFF the Click Sound, Beep Sound, and Warning Display, Setting the Brightness of the LCD Monitor 13-7
Chapter 14 Troubleshooting and Maintenance	
14.1	Troubleshooting 14-1
14.2	Messages 14-2
14.3	Using the Error Logging Function 14-4
14.4	Performing a Self-test 14-5
 14.5	Adjusting the Time Base 14-8
 14.6	Executing the Performance Test 14-10
 14.7	Replacing the Power Fuse 14-20
14.8	Recommended Replacement Parts 14-21
Chapter 15 Specifications	
15.1	Measurement Input and Trigger 15-1
15.2	Measurement Functions (Measurement Items) 15-2
15.3	Gate, Arming, and Inhibit 15-4
15.4	Block Sampling 15-4
15.5	Display 15-5
15.6	Auto Window Function 15-6
15.7	Inter-symbol Interference Analysis Function (Option) 15-7
15.8	Rear Panel Input/Output 15-7

15.9 GP-IB Interface	15-7	1
15.10 SCSI (Option)	15-8	
15.11 Time Base	15-8	2
15.12 Internal Memory Function	15-8	
15.13 Built-in Printer	15-9	3
15.14 Built-in Floppy Disk Drive	15-9	
15.15 Internal Hard Disk Drive (Option)	15-9	3
15.16 General Specifications	15-10	
15.17 External Dimensions	15-12	
Index	Index-1	4

1

2

3

4

5

6

7

8

9

10

11

12

13

14

15

Index

1.1 System Configuration and Block Diagram

System Configuration

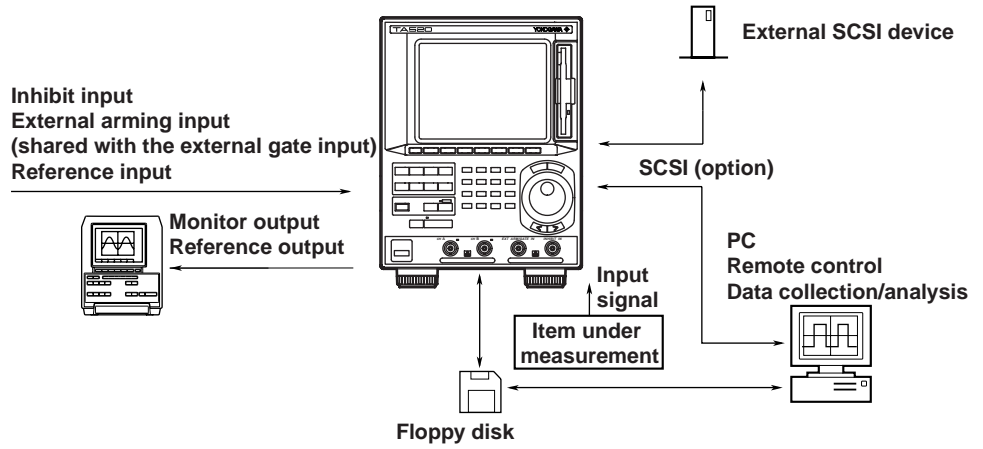

Block Diagram

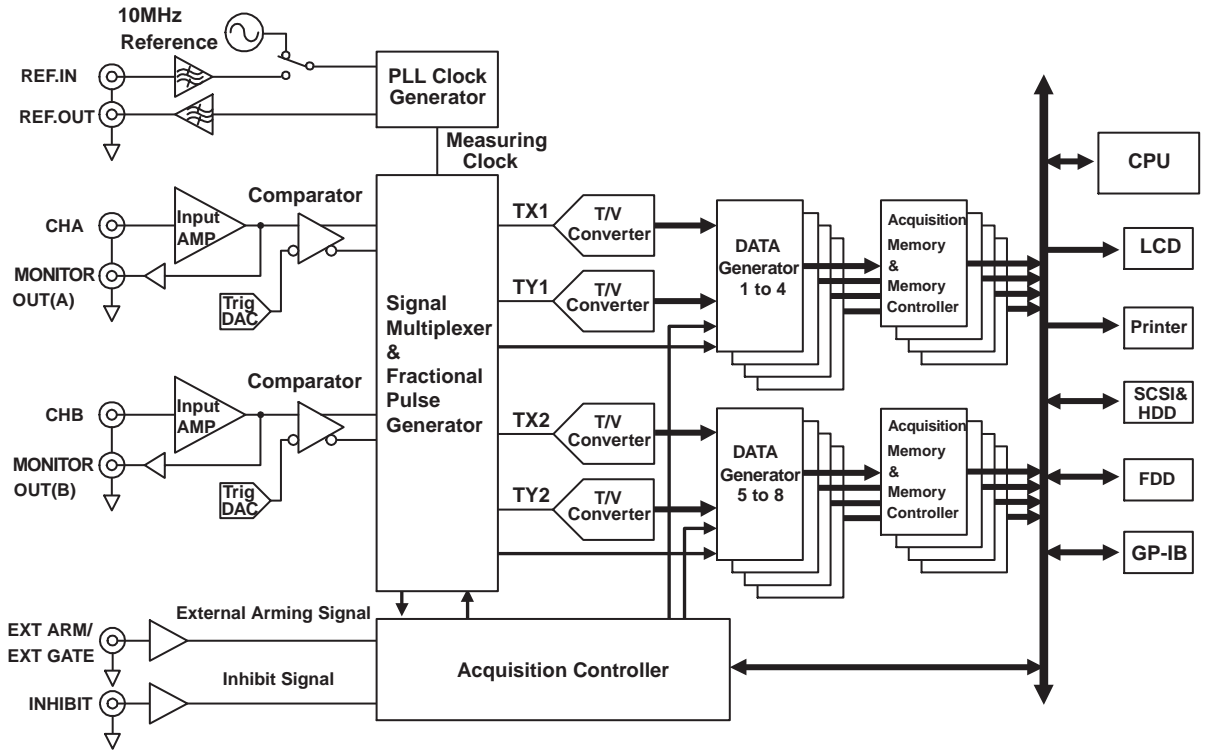

Signal Flow

A signal that is input to the input terminal (Ach/Bch) is converted to a low-impedance signal by the input amplifier (Input AMP). It is then passed to the comparator where it is converted to a binary signal. The signal from the input amplifier is also output as a monitor signal (MONITOR OUT(A)/MONITOR OUT(B)).

The signal multiplexer selects the measurement signal according to the specified measurement function (item) and outputs the fractional sections according to the measurement clock as fractional pulses. The fractional pulse width is measured with 25-ps resolution by the time/voltage converter (T/V Converter) and sent to the data generator where the measured data are generated.

The TA520 has eight data generator systems that generate data alternately. The acquisition controller controls the overall acquisition process including the external arming signal or inhibit signal.

In the time stamp mode, both the measured values and time stamp data (elapsed time) are acquired in the acquisition memory. In the hardware histogram mode, however, only the frequencies of occurrence of each measured value are acquired in the acquisition memory. The acquired data are read by the CPU via the memory controller, at which point the data are used in statistical calculations or displayed on the LCD.

Either the signal from the internal crystal oscillator (compensated against temperature drift) or an external reference signal (signal from the REFERENCE IN terminal) can be used as the reference signal. In either case, the signal is passed through a 10-MHz band-pass filter and output as a reference clock output. The measurement clock uses the frequency multiples of this reference clock.

1.2 Measurement Principle

Measurement Principle

Time shorter than the period of the reference clock is called fractional time. In general, since the signal being measured and the measurement clock are not synchronized, fractional time exists at both the beginning and the end of measurements. This instrument generates a "fractional pulse" which is a pulse signal amounting to the sum of the fractional time and one cycle of the reference clock.

If the pulse width of the signal being measured, the period of the measurement clock, and the times of the fractional pulses are taken to be T , t_0 , T_a , and T_b , respectively, T can be broken into two terms: integer multiple of the measurement clock, $N \cdot t_0$, and the time of the fractional pulses, T_a, T_b .

$$T = N \cdot t_0 + (T_a - T_b)$$

This instrument converts the time (T_a, T_b) of the fractional pulse that it generated at the beginning and end of the measurement to voltage values, which are then converted to digital values using an 8-bit A/D converter.

In this way, the instrument is able to measure the time of the fractional pulse at 25-ps time resolution per 1 LSB. T is determined by substituting the measured times of the fractional pulses into the variables T_a and T_b of the above equation.

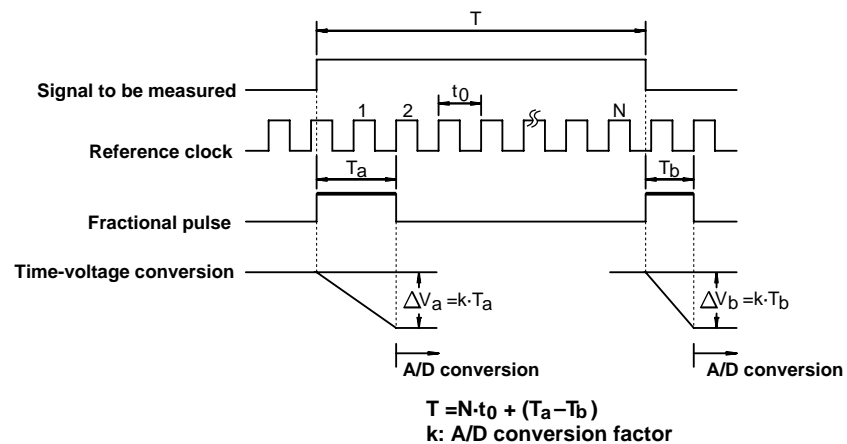

1.3 Sampling Mode

Sampling Mode ≡See 5.1 for the operating procedures≡

There are two sampling modes, time stamp mode and hardware histogram mode. The sampling method (data acquisition method), the display format after measurements, and methods of analysis and calculation vary depending on the sampling mode. For details on the display format, see section 1.7 “Displaying the Measured/Calculated Results.”

Time stamp mode

The measured values and their time stamps* are acquired in the acquisition memory and are handled as time-series data. The maximum sampling size (maximum number of data points that can be acquired) is 512,000 points. There are four types of display formats: histogram, list (measured values and time stamps), time variation, and statistics.

* The time elapsed from the point the arming occurred to the point the measurement of one sample ended is called a time stamp.

Hardware histogram mode

The measured values and the frequencies of occurrence of those values are acquired in the acquisition memory. The maximum sampling size (maximum number of data points that can be acquired) is 10^9 points. There are three display formats: histogram, list (measured values and frequencies of occurrence), and statistics.

The differences between the time stamp mode (T.S.) and hardware histogram mode (H.H.)

	T.S.	H.H.
Histogram display	Yes	Yes
List display	Yes	Yes
Time variation	Yes	No
Statistics display	Yes	Yes
Multi-window function	No* ¹	Yes
Maximum sampling size	512,000	10^9
Longest sampling time	320 s* ²	3200 s

*1 When using the ISI (inter-symbolic interference analysis function) in the T.S. mode, the multi-window function is used.

*2 320 s when the sampling interval is set to [0 μ s], 3200 s when it is set to anything else.

1.4 Measurement Functions (Measurement Items)

Period

≡See 5.2 for the operating procedures≡

Measures the pulse interval (time between rising edges or falling edges) of the input signal. Either rising edge or falling edge can be selected. Channel A or B can be selected for the measurement.

Example (rising slope is selected)

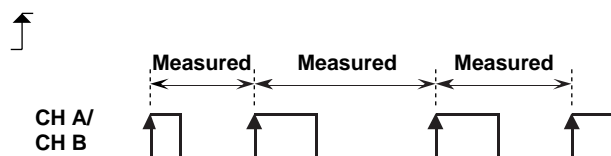

Time Interval

≡See 5.3 for the operating procedures≡

Measures the time between the edge of the input signal of channel A and the first edge of the input signal of channel B. For the various combinations of slopes, see section 5.3 "Setting the Time Interval Measurement."

Example (Both channels A and B: rise)

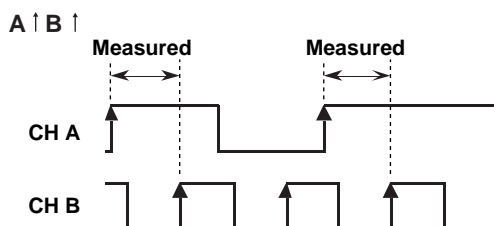

Example (Channel A: both rise and fall, channel B: rise)

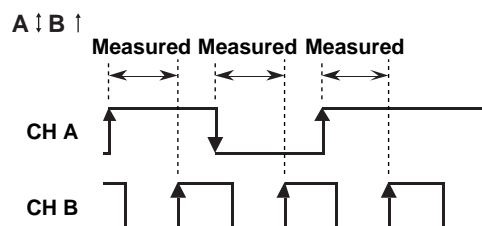

Pulse Width

≡See 5.4 for the operating procedures≡

Measures the time of the positive side (between the rising edge and falling edge) or the negative side (between the falling edge and the rising edge) of the input signal. For the various patterns of polarities, see section 5.4 "Setting the Pulse Width Measurement." Channel A or B can be selected for the measurement.

Example (positive: rising to falling)

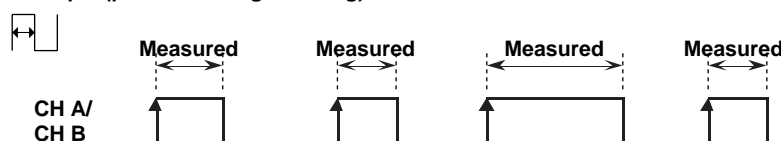

1.5 Acquisition Conditions for the Input Signal Being Measured

Measurement Block

The TA520 repeats the process of making measurements, processing data, and displaying the result. The “measurement block” refers to the smallest unit of measurement that is handled in one cycle of the process. If the number of samples (number of data points) acquired in one cycle of the process is N , then “one measurement block” refers to measuring, processing, and displaying N samples of data. As shown in the examples below, each sample (S_1, S_2, S_3 , to S_N) in the measurement block is measured for the corresponding sampling pulse (P_1, P_2, P_3 , to P_N) that occurs according to the specified sampling interval (see the section on sampling interval given later).

When the period of the input signal is longer than the sampling interval

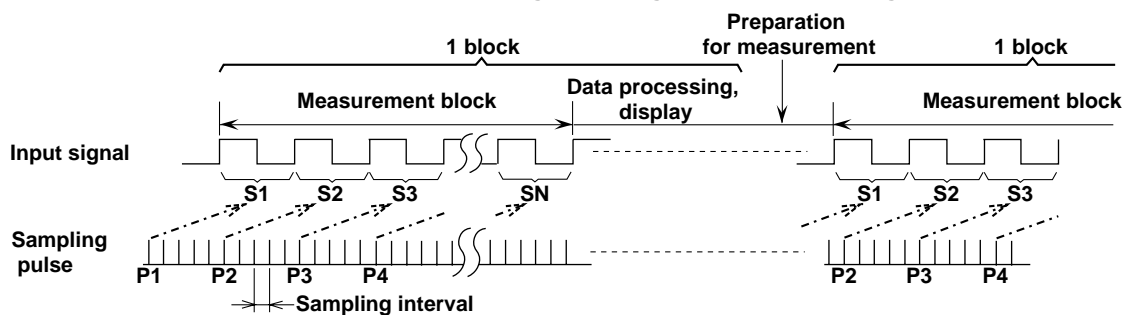

When the period of the input signal is shorter than the sampling interval

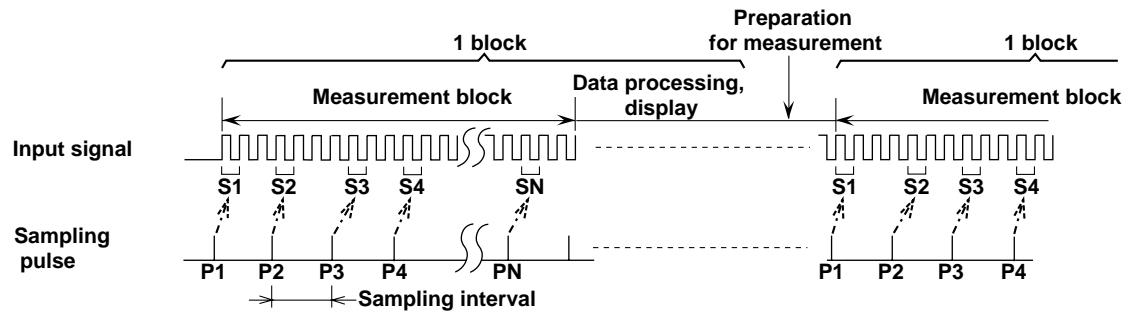

Block Sampling ≡See 6.3 for the operating procedures≡

The single measurement block explained above can be repeated N times. Repetitively measuring “one measurement block” N times is called block sampling.

In block sampling, data processing and display are done after measuring all N blocks of data. Also, in block sampling, you can set a pause time, defined as the period of time between block measurements.

The display and analysis of data that has been block sampled varies depending on the sampling mode as follows.

During the time stamp mode

The list and time variation for each measurement block can be displayed and statistical calculations can be performed.

The maximum selectable block size (number of repetitions: N) is 100.

During the hardware histogram mode

An histogram of all measurement blocks can be displayed and statistical calculations can be performed on them. Lists and statistical calculations on each block are not allowed.

The maximum selectable block size (number of repetitions: N) is 1000.

The relationship between the pause time and arming during block sampling is shown below.

For Arming: Ext/with arming delay, pause time: OFF

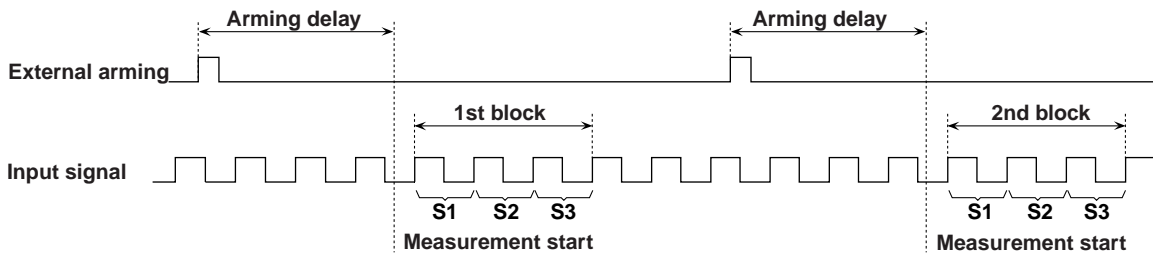

For Arming: Ext/no arming delay, pause time: enabled

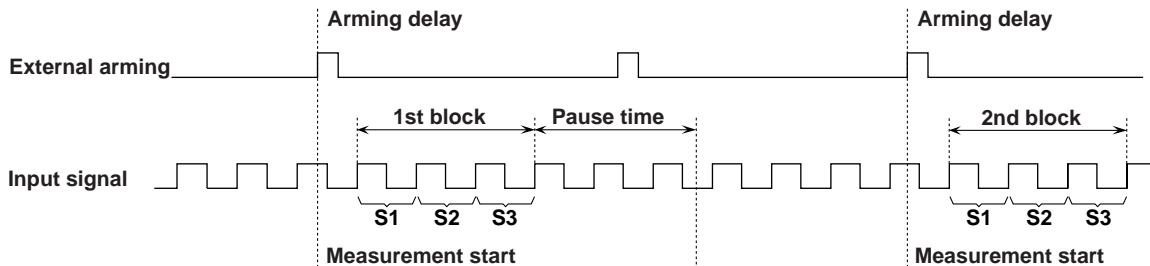

For Arming: Auto, pause time: OFF

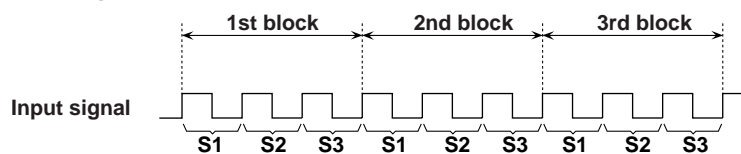

For Arming: Auto, pause time: enabled

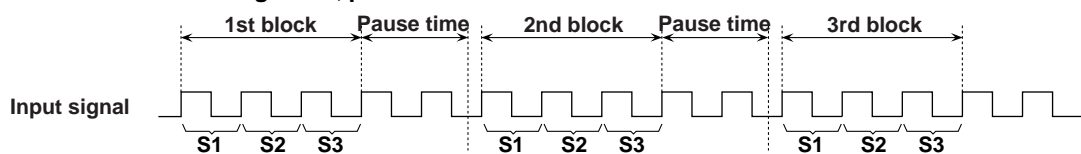

1.5 Acquisition Conditions for the Input Signal Being Measured

Gate

≡See 6.1 for the operating procedures≡

You can specify the size of a measurement block in terms of the number of events or the gate time. Measurement is carried out for the number of events or over the time when the gate is open. There are three types of gates.

Event gate

Each sample is called an event. For example, measurement of one period is equivalent to one event. Up to 512,000 events during time stamp mode, and up to 10^9 events during the hardware histogram mode can be set as long as the time is within the maximum sampling time (see page 1-4) since arming (see next page).

Time gate

Up to 10 s of gate time can be set as long as the maximum sampling size of each sampling mode is not exceeded.

External gate

The external arming input terminal (see next page) is used to control the gate. The gate can be open for up to the longest allowed sampling time (see page 1-4) as long as the maximum sampling size of each sampling mode is not exceeded. You can also select which polarity, positive or negative, to use in opening the gate.

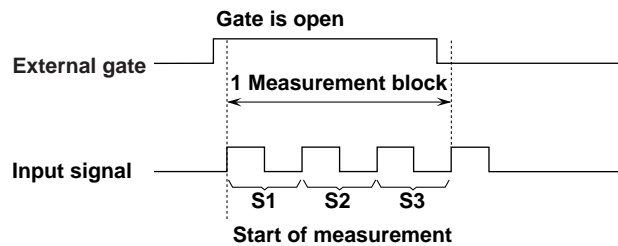

Sampling Interval ≡See 6.2 for the operating procedures≡

The sampling interval is the interval at which data samples are acquired. Samples are acquired continuously at the specified interval. However, samples cannot be acquired continuously if the period of the input signal is shorter than 23 ns. The operation varies depending on the sampling mode.

During time stamp mode

The TA520 generates sampling pulses (see the measurement block section described earlier) at the sampling interval. After the sampling pulse, when the input signal meets the trigger condition (trigger level, slope, etc.), a measurement is made. The available sampling intervals are 0 μ s and 1 μ s to 1 s. When 0 μ s is selected, the data are sampled at approximately 23 ns intervals.

During hardware histogram mode

The sampling interval is fixed to approximately 23 ns and cannot be changed.

Arming

≡See 6.4 for the operating procedures≡

Arming is the trigger that starts the measurement of a measurement block. There are two types of arming: auto arming in which the measurement starts when the START key is pressed or the START command is issued, and external arming in which the measurement starts when an external signal is received.

Auto arming

Arming is activated automatically after the START key is pressed or the START command is issued. In this case, the arming source is an internal signal.

External arming

After the measurement is started, arming is activated by applying a signal to the external arming input terminal. In this case, the arming source is an external signal. You can select whether the rising or falling edge is used to activate the arming. The following signal levels (arming levels) are available: TTL (1.4 V), TTL/10 (0.14 V), and 0 V.

**Arming Delay**

≡See 6.4 for the operating procedures≡

When using external arming, you can delay the start of the measurement by a certain amount of time or number of events after an arming occurs.

There are two types of arming delays.

Time delay

The measurement starts after being delayed for the specified time (up to 1 s).

Event delay

The measurement starts after being delayed for the specified number of events (up to 1000000).

Inhibit

≡See 6.5 for the operating procedures≡

You can inhibit measurements by applying a signal to the INHIBIT input terminal. This is possible even while the gate is open or during measurement after arming activation. You can inhibit measurements for time periods as long as the longest allowed sampling time (see page 1-4).

You can select whether the positive or negative polarity of the signal will be used to inhibit the measurement. The following signal levels (inhibit) are available: TTL (1.4 V), TTL/10 (0.14 V), and 0 V.

The following examples show some of the relationships between the inhibit signal and gating/arming.

Relation between the inhibit signal and gating

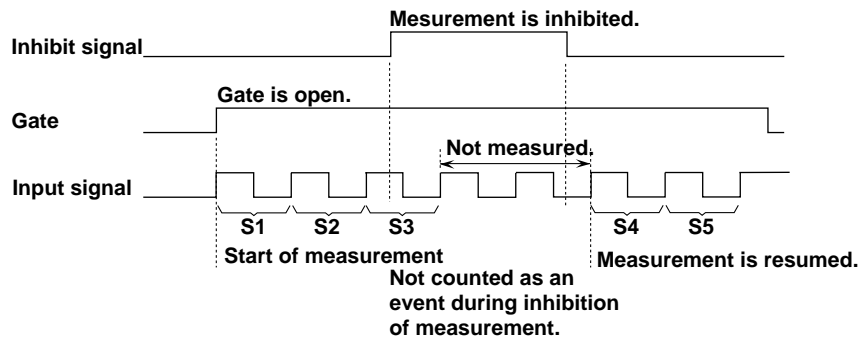

Relation between the inhibit signal and gating/external arming

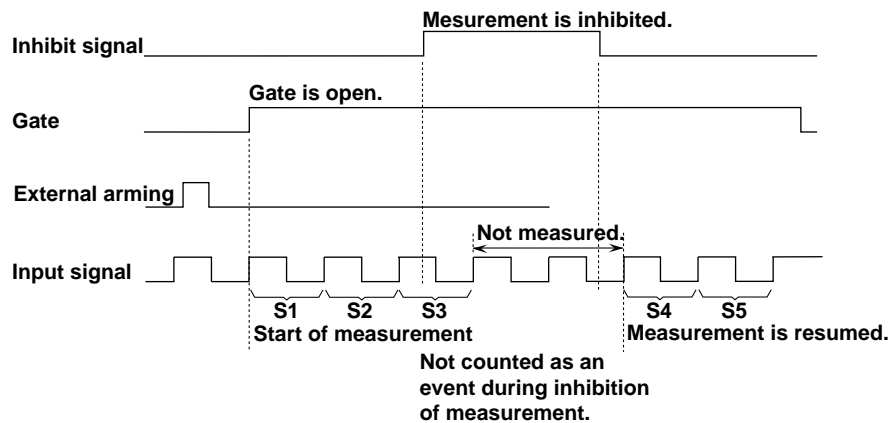

Relation between the inhibit signal and gating/external arming/arming delay

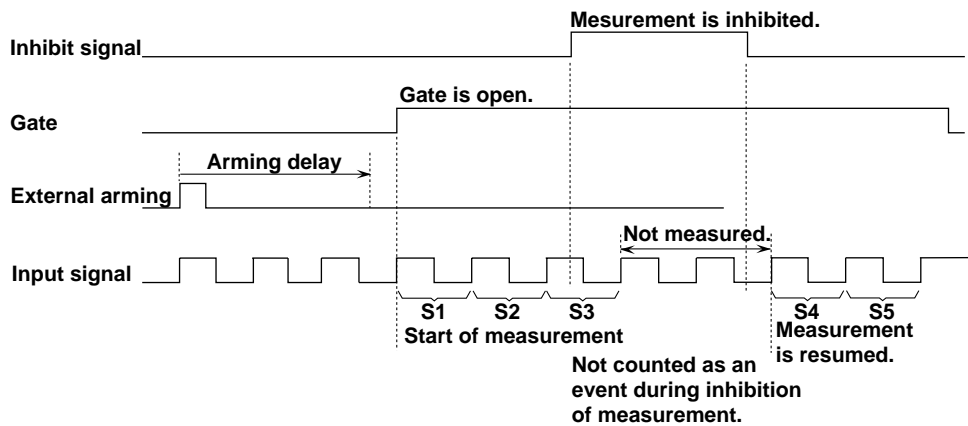

Input Coupling ≡See 6.6 for the operating procedures≡

When you want to measure just the amplitude (AC component) of an input signal or a signal riding on top of a certain DC voltage, measurements can be facilitated if the DC component is removed from the signal. In other cases, you may want to measure both the AC and DC components of the input signal. In these cases, an appropriate input coupling is applied to the signal when entering the input amplifier. The following types of input coupling are available:

AC

The signal is input through a capacitor. This setting is used to remove the DC component from the input signal in order to measure just the amplitude of a signal or a signal riding on top of a certain DC voltage.

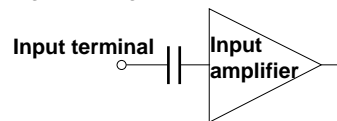
**DC**

The signal is input directly to the amplifier. This setting is used when measuring both the AC and DC components of a signal.

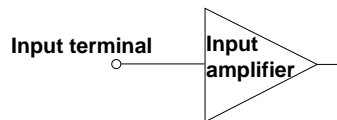
**Input Impedance** ≡See 6.6 for the operating procedures≡

To reduce attenuation and distortion of the measurement signal, the input impedance of CHA and CHB of the instrument can be selected so that it matches the output impedance of the signal source. The available settings are 50 Ω and 1 M Ω .

1.5 Acquisition Conditions for the Input Signal Being Measured

Trigger Mode/Trigger Level ≡See 6.6 for the operating procedures≡

When measuring one sample, you can select the level at which the measurement is to be carried out (trigger condition). The level at which to activate the trigger is called the trigger level.

Manual trigger

The trigger level is set to the value that is specified using the rotary knob or the numerical keys.

Single auto trigger

Taking the maximum and minimum values of the input signal during the first measurement block to be 100% and 0%, respectively, the trigger level is set to the specified percentage level. The trigger level for all following blocks is set to this level.

Repeat auto trigger

Taking the maximum and minimum values of the input signal during the first measurement block to be 100% and 0%, respectively, the trigger level is set to the specified percentage level. Unlike single trigger, the trigger level is reset for each measurement block.

When the [Level] is set to 50% using single auto trigger

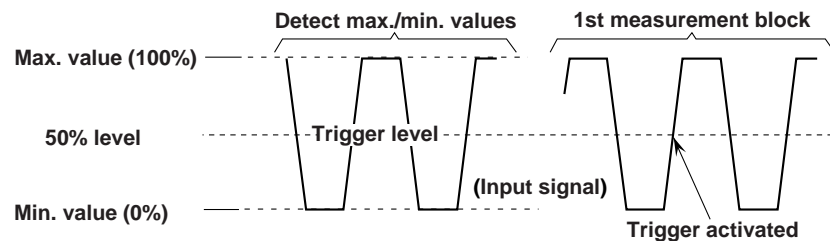

Reference Signal I/O ≡See 6.7 for the operating procedures≡

Reference input

The instrument has an internal reference clock used for making measurements. However, a 10-MHz external signal can be applied to the REFERENCE IN terminal on the rear panel and can be used as the reference clock instead.

Reference output

The internal reference clock signal or the externally applied reference clock signal is passed through a 10-MHz band-pass filter and is continuously output from the REFERENCE OUT terminal.

1.6 Analysis and Calculation

Readout Function ≡ See 7.8 and 8.9 for the operating procedures ≡

X1, X2, and Y markers can be displayed for histogram displays (see section 1.7). X1, X2, Y1, and Y2 markers can be displayed for time variation displays (see section 1.7). The coordinates of the cross points of these markers and the histogram and time variation graphs can be read. In addition, statistical calculation can be performed independently over the area enclosed by the markers (see next section).

For histogram displays

The values shown on the bottom of the graph represent the following:

X1: X coordinate (measured value) of the X1 marker

V1: Y coordinate (frequency of occurrence X1) of the X1 marker

X2: X coordinate (measured value) of the X2 marker

V2: Y coordinate (frequency of occurrence X2) of the X2 marker

ΔX : $X2 - X1$

Num: Number of samples used in the statistical calculation

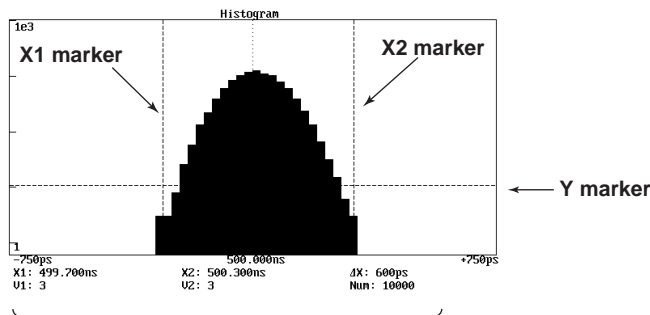

For time variation displays

The values shown on the bottom of the graph represent the following:

X1: X coordinate (time stamp) of the X1 marker

V1: Y coordinate (measured value) of the X1 marker

X2: X coordinate (time stamp) of the X2 marker

V2: Y coordinate (measured value) of the X2 marker

ΔX : $X2 - X1$

ΔV : $|V2 - V1|$

Y1: Y coordinate (measured value) of the Y1 marker

Y2: Y coordinate (measured value) of the Y2 marker

ΔY : $|Y2 - Y1|$

T.Num: Number of samples used in the statistical calculation

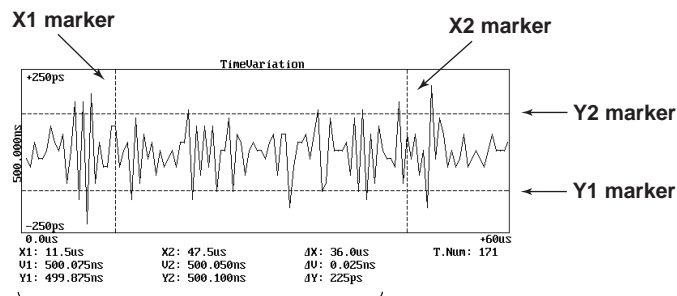

Note

- The Y marker on the histogram display is used to set the area for performing statistical calculations.
- During time variation display, if there are multiple data points at the marker position, the average value is displayed. If there is no data at the marker position, an asterisk (*) is displayed.

Statistical Calculation ≡See 7.6 and 8.7 for the operating procedures≡

You can set the area on which to calculate statistics, the constant T, and the parameters to be calculated.

Select the area to be used in the statistical calculations

Select whether to calculate the statistics over the entire window or the area enclosed by the markers.

If the time variation is displayed on data that was block sampled in the time stamp mode, you can also select the [Block] on which to calculate the statistics.

If you are using the multi-window or auto window function, the statistics are calculated over the area enclosed by markers for each window.

When calculating the statistics over an area enclosed by markers

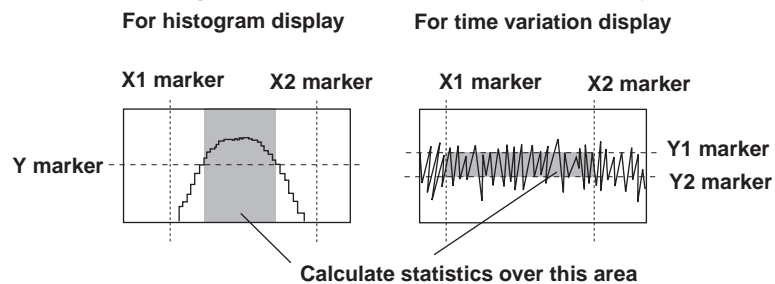

Setting the slope (Calculation Slope) and polarity (Calculation Polarity)

You can specify the slope and polarity for the statistical calculation only for the following measurement functions.

The statistics can be calculated separately on data having the specified slope or polarity.

- For time interval measurements, when the slope setting is either **A ↑ B ↑** or **A ↑ B ↓**.
- For pulse width measurements, when the polarity setting is

Setting the Constant T

Set the constant T used when calculating the statistical values jitter and MELE. This value corresponds to the read-out clock when the measured device is an optical disk or optical disk drive.

You cannot change the value of T when using the auto window function since it is automatically set.

Statistical calculation parameters

Statistics can be calculated based on the measured values (during time stamp mode) or histogram (during hardware histogram mode). The results of the statistical calculation can be displayed on the histogram, statistic, and time variation displays (see section 1.7).

The equations used to calculate some of the statistics vary depending on the sampling mode. In addition, in the time stamp mode, you can select to calculate the statistics on the time variation or on the histogram.

During the time stamp mode

The following differences exist between the time variation display and the histogram display.

Time variation: You can set the area over which to calculate the statistics with the time stamp and measured value.

Histogram : You can set the area over which to calculate the statistics with the measured value (bin) and frequency of occurrence.

In the following equations, n is the number of samples, X_i is the measured value of each sample, and X_j (only for histograms) is the class value of each bin of the histogram.

If the statistics are calculated on the time variation, "T." is placed in front of the statistical calculation parameter names.

- **Average value**

Calculates the average value of the measured values.

$$\text{Average} = \frac{1}{n} \sum_{i=1}^n X_i$$

- **Maximum value**

Indicates the maximum measured value.

$$\text{Maximum} = [X_i]_{\max}$$

- **Minimum value**

Indicates the minimum measured value.

$$\text{Minimum} = [X_i]_{\min}$$

- **Peak-to-Peak**

Calculates the difference between the maximum and minimum values.

$$\text{Peak - Peak} = \text{Maximum} - \text{Minimum}$$

- **Standard deviation (σ)**

Calculates the standard deviation of the measured values. This indicates the degree to which the values are spread out from the average value.

$$\sigma = \sqrt{\frac{1}{n} \sum_{i=1}^n (X_i - \text{Average})^2}$$

- **Flutter ($\sigma/\text{Average}$)**

Measures the flutter. This indicates the spread in the values in terms of a percentage of the average value.

$$\sigma / \text{Average} = \frac{\sigma}{\text{Average}} \times 100 (\%)$$

- **σ/T (only for histograms)**

Calculates the histogram jitter using the specified constant T. Indicates the spread of the values in terms of a percentage of the value T.

$$\sigma / T = \frac{\sigma}{T} \times 100 (\%)$$

- **Effect Length Error, E.L.Error for short (only for histograms)**

X_{CENTER} is the center value of the x axis in the window. See section 1.7 for details. Originally, X_{CENTER} represented the value around which the measured data would be distributed.

Indicates the offset of the measured average value with respect to X_{CENTER} .

$$\text{E.L.Error} = \text{Average} - X_{\text{CENTER}}$$

- **Maximum Effect Error, MELE for short (only for histograms)**

Indicates the offset of the measured average value with respect to X_{CENTER} in terms of a percentage of the value T.

$$\text{MELE} = \frac{|\text{Average} - X_{\text{CENTER}}|}{T} \times 100 (\%)$$

1.6 Analysis and Calculation

- **Median (only for histograms)**

Indicates the median of the histogram.

$$\text{Median} = [X_j]_{\text{Median}}$$

- **Mode (only for histograms)**

Indicates the class value with the highest frequency of occurrence (most frequent value).

$$\text{Mode} = [X_j]_{\text{Mode}}$$

- **T.(P-P/Average)**

Indicates the spread in the Peak-to-Peak values in terms of a percentage of the average value.

$$T.(P-P/Average) = \frac{P-P}{\text{Average}} \times 100$$

- **T.RF (only for time variation)**

Calculates the average value of T.(P-P/Average) of all blocks that were block sampled.

N is the total number of blocks. P-P_k is the Peak-to-Peak value of each block, and AVE_k is the average value of each block.

$$T.RF = \frac{1}{N} \sum_{k=1}^N \left(\frac{P-P_k}{AVE_k} \times 100 \right)$$

During the hardware histogram mode

In the equation below, n is the number of bins in the histogram. A bin of a histogram refers to a bar that indicates the frequency of occurrence on the histogram. Xi is the class value of each bin of the histogram. Depending on the span setting of the X-axis, the interval width of each bin becomes 25 ps in which case Xi becomes the measured value. For details, see section 1.7 "Histogram Display."

- **Average**

Calculates the average value of the histogram. Pi is the relative frequency*.

$$\text{Average} = \sum_{i=1}^n X_i \times P_i$$

* If the total number of samples on which the statistics are being calculated is N, and the frequency of occurrence (number of samples) of a certain bin is Ni, then the relative frequency becomes Pi = Ni/N.

- **Maximum value**

Indicates the maximum class value.

$$\text{Maximum} = [X_i]_{\text{max}}$$

- **Minimum value**

Indicates the minimum class value.

$$\text{Minimum} = [X_i]_{\text{min}}$$

- **Peak-to-Peak**

Calculates the difference between the maximum and minimum values.

$$\text{Peak- Peak} = \text{Maximum} - \text{Minimum}$$

- **Standard deviation (σ)**

Calculates the standard deviation of the histogram. This indicates the degree to which the values are spread out from the average value. P_i is the relative frequency.

$$\sigma = \sqrt{\sum_{i=1}^n (X_i - \text{Average})^2 \times P_i}$$

- **Flutter ($\sigma/\text{Average}$)**

Measures the flutter of the histogram. Indicates the spread in the values from the average value in terms of a percentage of the average value.

$$\sigma / \text{Average} = \frac{\sigma}{\text{Average}} \times 100 (\%)$$

- **σ/T**

Calculates the histogram jitter using the specified constant T. Indicates the spread in the values in terms of a percentage of the value T.

$$\sigma / T = \frac{\sigma}{T} \times 100 (\%)$$

- **Effect Length Error, E.L.Error for short**

X_{CENTER} is the center value of the x axis in the window. See section 1.7 for details. Originally, X_{CENTER} represented the value around which the measured data would be distributed.

Indicates the offset of the actually measured average value with respect to X_{CENTER} .

$$\text{E.L.Error} = \text{Average} - X_{\text{CENTER}}$$

- **Maximum Effect Length Error, MELE for short**

Indicates the offset of the measured average value with respect to X_{CENTER} in terms of a percentage of the value T.

$$\text{MELE} = \frac{|\text{Average} - X_{\text{CENTER}}|}{T} \times 100 (\%)$$

- **Median**

Indicates the median of the histogram.

$$\text{Median} = [X_i]_{\text{Median}}$$

- **Mode**

Indicates the class value with the highest frequency of occurrence (most frequent value).

$$\text{Mode} = [X_i]_{\text{Mode}}$$

1.7 Displaying the Measured/Calculated Results

Histogram Display ≡ See 7.1 and 8.1 for the operating procedures ≡

By displaying the histogram (frequency distribution) of the measured data, you can see the data distribution. You can manually set the X-axis (time) and Y-axis (frequency) of the histogram. You can also have them set automatically using the auto scale function. The following items can be set.

- The center value of the X-axis (X Center)
- The X-axis width (X Span)
- The scaling format of the Y-axis (select linear scale or log scale)
- The maximum Y-axis value (Y High)

Frequency distribution

The histogram is displayed according to the settings made for the above values. If a class has a time span, the average value will be used as the class value. For example, if the minimum and maximum values in a class are 505 ns and 515 ns, respectively, 510 ns will be treated as the class value. The samples in this class are all considered to correspond to 510 ns (if the value is read out with the marker, the class value is read out).

As shown in the diagram below, each value on the X-axis of the instrument represents a class value or a displacement. The histogram is created by accumulating the number of samples that fall in each class.

Y-axis Scale (Log scale for this example)

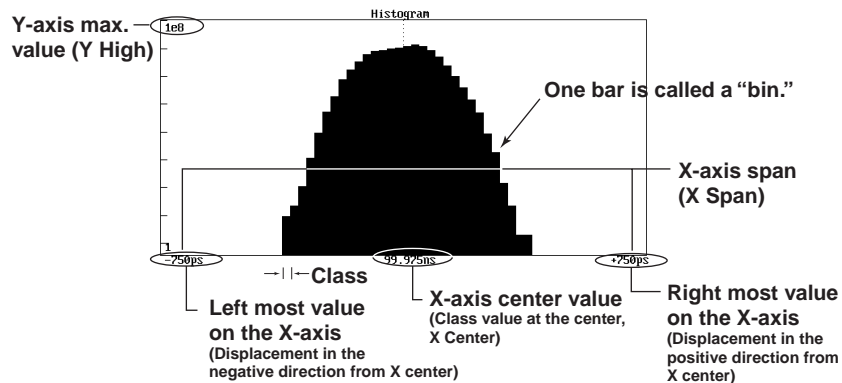

Items that can be displayed

Besides the histogram, you can select whether or not to display the marker read-out values, the statistics, and a panorama window.

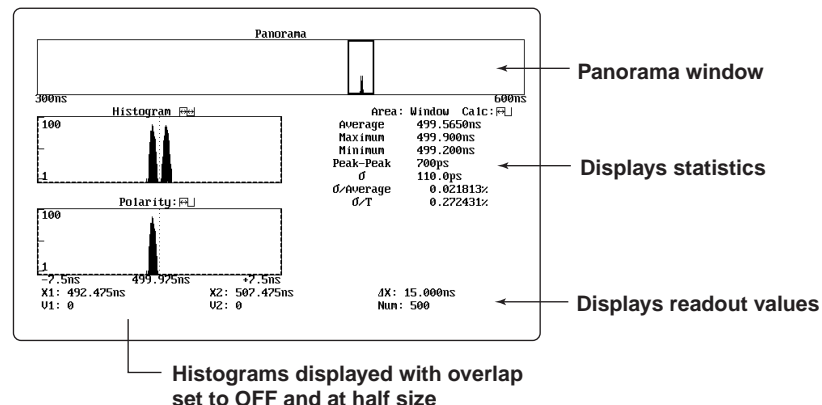

List Display

≡See 7.2 and 8.2 for the operating procedures≡

Display a list of the measured data. You can move and display different parts of the list using the jump function which can move to the top, center, or end of the data or by specifying the data number. The displayed contents vary depending on the sampling mode as follows:

During time stamp mode

The time stamp and measured values are listed within the range of the number of events or time specified for the [gate] (see section 1.5). The specified data number is highlighted and the time variation waveform corresponding to the data number displays a dotted line and a ◀ mark.

When block sampling, each block can be individually listed by specifying the number of the measurement block.

Number	Time Stamp	Measured data
802	141.0 us	-5.125 ns
803	141.2 us	15.250 ns
804	141.3 us	-1.750 ns
805	141.4 us	15.325 ns
806	141.5 us	-2.875 ns
807	141.7 us	16.500 ns
808	141.8 us	-5.825 ns
809	142.0 us	15.000 ns
810	142.1 us	1.075 ns
811	142.3 us	16.650 ns

Labels: Data number (points to Number), Time stamp (points to Time Stamp), Measured value (points to Measured data).
Annotation: Highlights the specified data (points to row 807).

During hardware histogram mode

The measured values (the class values of the histogram) and the frequencies are listed within the range of the width of the X-axis (X Span) of the histogram display. The specified data number is highlighted and the time variation waveform corresponding to the data number displays a dotted line and a ◀ mark.

When using the multi-window or auto window function, the list is displayed for each window (3T, 4T, All, etc.).

Number	Measured data	Frequency
881	-2.450 ns	10
882	-2.425 ns	12
883	-2.400 ns	8
884	-2.375 ns	13
885	-2.350 ns	17
886	-2.325 ns	14
887	-2.300 ns	12
888	-2.275 ns	24
889	-2.250 ns	18
890	-2.225 ns	11

Labels: Data number (points to Number), Class value (points to Measured data), Frequency (points to Frequency).
Annotation: Highlights the specified data (points to row 888).

1.7 Displaying the Measured/Calculated Results

Time Variation Display ≡See 7.3 for the operating procedures≡

During the time stamp mode, the measured data and time stamps are treated as data and acquired to the acquisition memory. The time variation display function uses this time-series data to display the variation of the measured value in relation to the elapsed time since the arming.

You can manually set the X-axis (time) and Y-axis (measured data) for the time variation display. You can also have them set automatically using the auto scale function. The following items can be set.

- The minimum X-axis value (X Minimum)
- The center value of the Y-axis (Y Center)
- The X-axis width (X Span)
- The Y-axis width (Y Span)

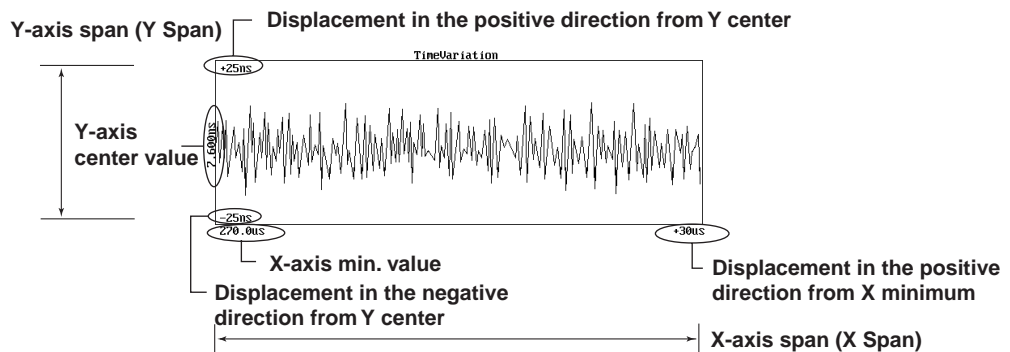

Items that can be displayed

Besides the histogram, you can select whether or not to display the marker read-out values, the statistics, and a panorama window.

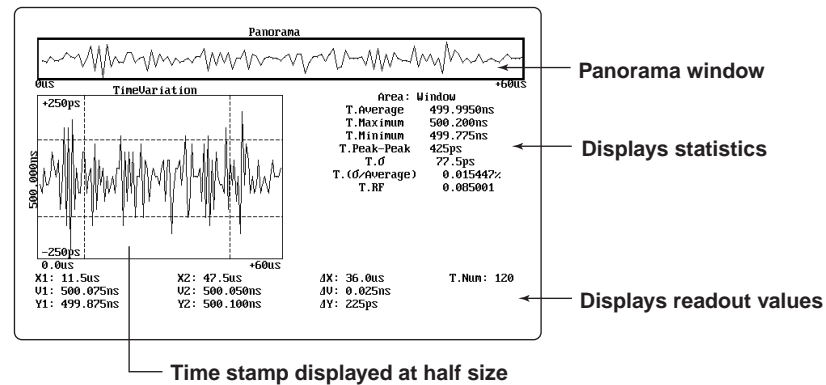

Display method

You can select whether or not to show the grid and whether or not to connect the data points with a line.

Statistics Display ≡See 7.4 and 8.3 for the operating procedures≡

The statistics are calculated over the area and on the items that are specified in the Calculation/Statistics setting menu that is accessed with the [Calc/Stat] soft key. A list of results is displayed. For information on the parameters of the statistical calculation, the details of the calculation, and the area, see section 1.6 "Analysis and Calculation." The displayed results vary depending on the sampling mode.

For time stamp mode

You can select to calculate the statistics of the histogram or of the time variation. Depending on the above selection, the statistical parameters that can be calculated vary.

When calculating the statistics of the histogram

Item	Value
Average	5.78800ns
Maximum	25.900ns
Minimum	-10.700ns
Peak-Peak	36.600ns
σ	4.49450ns
σ/T	*****
$\sigma/\text{Average}$	*****
E.L. Error	*****
MELE	*****
Median	*****
Mode	*****
Number	10000

When calculating the statistics of the time variation

Item	Value
T.Average	37.0675ns
T.Maximum	37.350ns
T.Minimum	36.825ns
T.Peak-Peak	925ps
T. σ	100.0ps
T.($\sigma/\text{Average}$)	0.270242%
T.(P-Average)	1.41665%
T.RF	1.403100%
T.Num	100

- If the statistics are calculated on the time variation, σ/T , E.L.Error, MELE, Median, and Mode are not calculated or displayed, but T.(P-P/Average) and T.RF are.
- If the statistics are calculated on the time variation of data that was block sampled, then you can select ALL or Block for the displayed statistics.
 - All : Display all of the statistics on each measurement block.
 - Block : Display only the statistics for the specified block.
- You can select the area over which the statistics are calculated from the following choices:
 - Window: Calculate over the entire window.
 - Marker : Calculate over the area enclosed by the markers.
 - Block : For data that was block sampled, calculate over each measurement block.
 - Calculate over all the data when block sampling is OFF.

For time interval measurement and pulse width measurement, the statistics can be displayed separately for each slope and polarity setting (see page 1-14 "Setting the slope and polarity").

1.7 Displaying the Measured/Calculated Results

For hardware histogram mode

When using single window, you can select the area over which to calculate the statistics from Window (entire window) and Marker (area enclosed by the markers).

When using the multi-window or auto window function, the statistics are calculated over the area enclosed by the markers. The following display styles are available for displaying the statistics:

- All : Display the statistics of all windows that were defined in the multi-window setting menu (example: 3T to 14T).
- Window: Display the statistics of the window that was defined in the [Window Parameter Setting] menu or the [Summation] window.

When Window is selected while using the multi-window function or when using single window

When ALL is selected while using the multi-window function

Statistics Value(Histogram)	Area: Window	Value
Average		114.42600nsec
Maximum		144.000nsec
Minimum		99.900nsec
Peak-Peak		44.100nsec
σ		3.40225nsec
σ/T		*****
σ/Average		*****
E.L. Error		*****
MELE		*****
Median		*****
Mode		*****
Number		31703

Window	Average	Maximum	Minimum
3T	114.42600ns	144.000ns	99.900ns
4T	157.30250ns	182.000ns	122.000ns
5T	194.62425ns	220.000ns	160.000ns
6T	229.81675ns	258.000ns	198.000ns
7T	266.37275ns	296.000ns	237.500ns
8T	303.8975ns	334.000ns	274.300ns
9T	342.5375ns	372.000ns	314.000ns
10T	371.5425ns	409.000ns	351.300ns
11T	402.0950ns	410.100ns	393.200ns
14T	512.5625ns	519.000ns	507.100ns

Statistics

Panorama Display ≡ See 7.5 and 8.4 for the operating procedures ≡

During the histogram display (only for the hardware histogram mode) or the time variation displayed, the measured data can be displayed in the upper section of the window (referred to as the panorama display). In addition, a section of the data that is displayed in the panorama display (waveform in the zoom box) can be displayed in the main window (zoom display). You can move the zoom box in the panorama window.

For time stamp mode

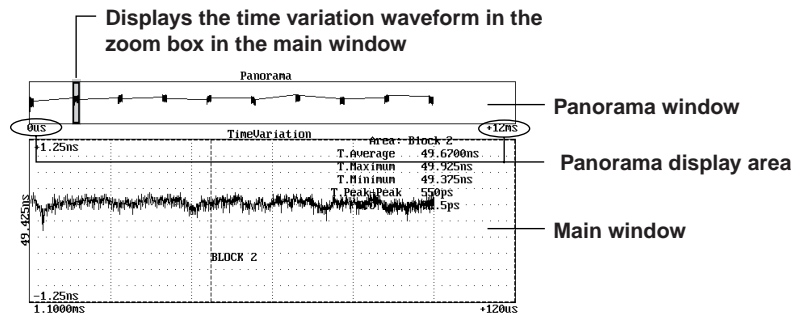

For hardware histogram mode

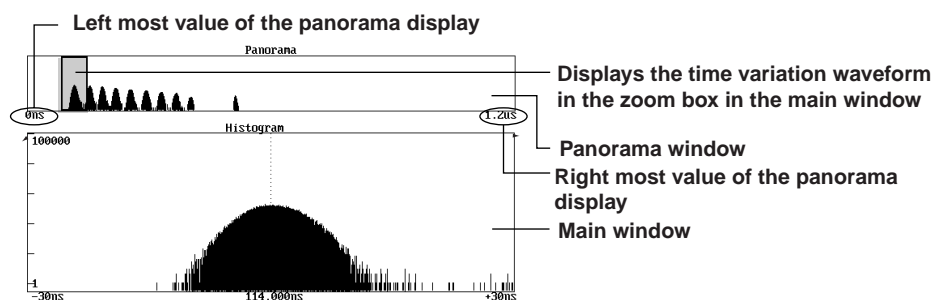

Multi-window function ≡See 8.5 for the operating procedures≡

When the distribution of the data of one measurement block is distributed over multiple center values on the X-axis, multiple histograms are created. You can simultaneously display all the histograms in the main window. However, you can also set multiple windows and display each histogram in its own window and observe it in detail. The function that allows for the setting of multiple windows and the display of the histogram of each window is called the multi-window function. Up to 16 arbitrary sized windows can be set.

By using this function in conjunction with the panorama display, you can easily see which histogram among the various windows is being displayed or set.

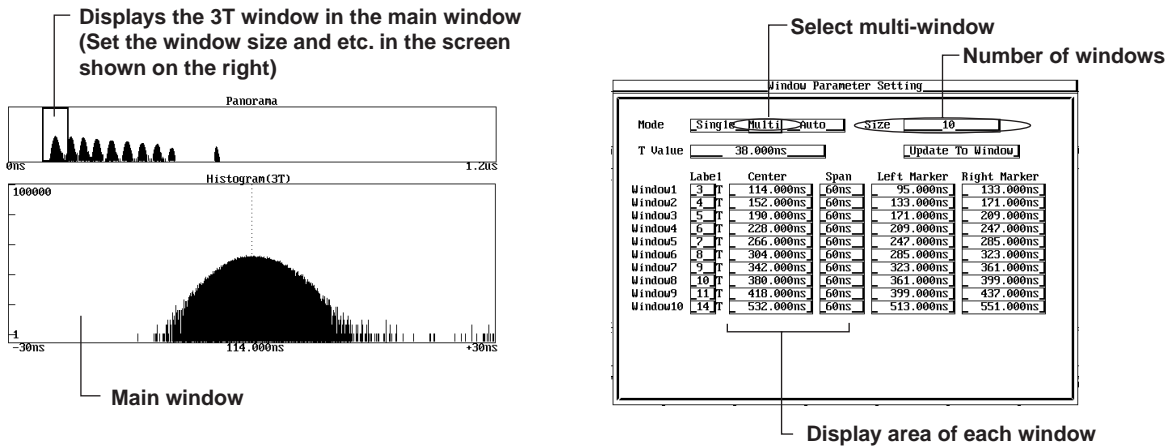

Summation display

The histograms (enclosed by the X1 and X2 markers) of all windows that have been set with the multi-window function can be summed and displayed in one window. The center values of the X-axis of the histogram of each window are aligned and the frequencies of each bin are summed.

Only the histograms in the area enclosed by the markers are summed.

You can compare the data distribution between each histogram and calculate the statistics of all histograms at once.

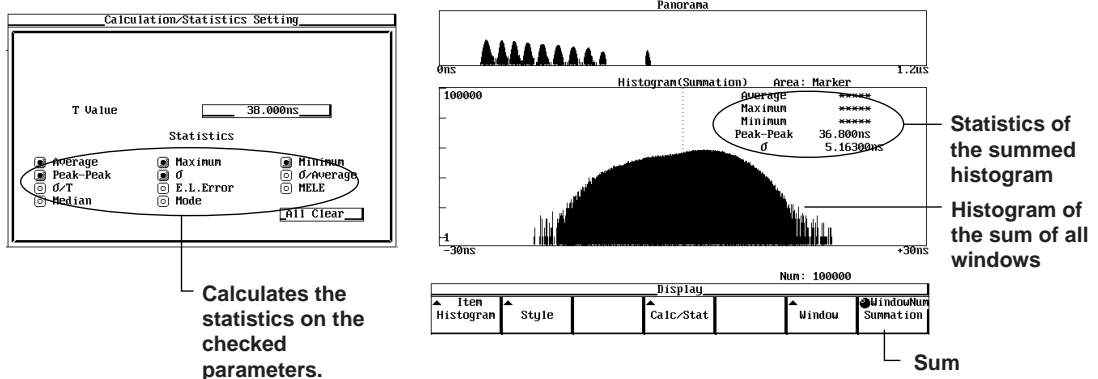

1.7 Displaying the Measured/Calculated Results

Auto window function ≡See 8.5 for the operating procedures≡

This function is used to measure the signal of several RLL (Run Length Limited) symbols for which the data rate is unknown. The clock period T is measured, and the X-axis values are automatically set.

The following modulation methods are supported:

- EFM modulation
- EFM+ modulation
- 1-7 modulation

There are two methods of automatic setting.

- Measured T: Apply the input signal to CHA and the read-out clock signal to CHB. The value of T is measured from the period of the clock signal.
- Estimated T: The value of T is estimated from the frequency distribution of the input signal and the modulation method. This is used when the clock signal cannot be inputted.

Select the method of automated measurement
Auto window
Select the modulation method

Label	Center	Span	Left Marker	Right Marker
Window1	120.000ns	60ns	100.000ns	140.000ns
Window2	160.000ns	60ns	140.000ns	180.000ns
Window3	200.000ns	60ns	180.000ns	220.000ns
Window4	240.000ns	60ns	220.000ns	260.000ns
Window5	280.000ns	60ns	260.000ns	300.000ns
Window6	320.000ns	60ns	300.000ns	340.000ns
Window7	360.000ns	60ns	340.000ns	380.000ns
Window8	400.000ns	60ns	380.000ns	420.000ns
Window9	440.000ns	60ns	420.000ns	460.000ns
Window10	500.000ns	60ns	540.000ns	580.000ns

Automatically configures the T value and X-axis values of each window

Scaling Function ≡See 7.7 and 8.8 for the operating procedures≡

To display the measured data, various values must be set such as the minimum value or the center value of the X-axis, the X-axis span, the center or the maximum value of the Y-axis, and the Y-axis span.

This instrument has auto scaling in which the X-axis and Y-axis parameters are automatically set according to the data. It also has manual scaling in which the X-axis and Y-axis parameters can be set arbitrarily.

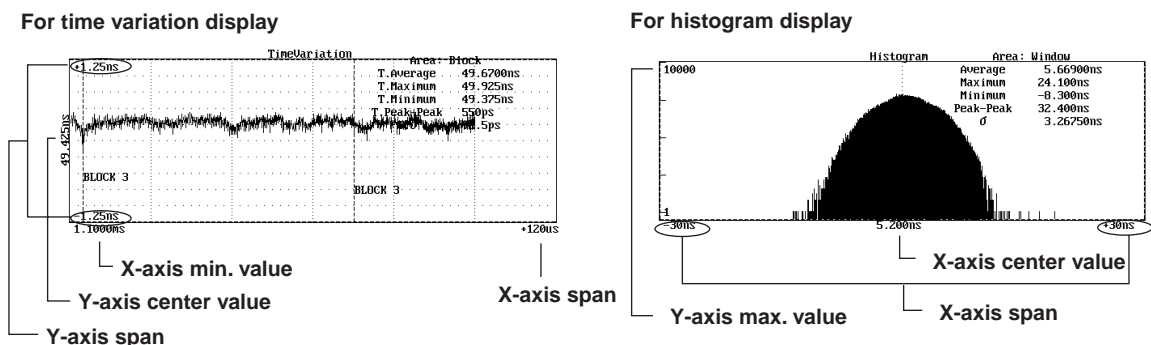

1.8 Other Functions

External Signal Input/Output ≡See chapter 6 and 13.3 for the operating procedures≡

Input/output terminals (BNC) for exchanging signals with external devices are provided on the front and rear panels. For the locations of the terminals, see section 2.1 "Front Panel" and 2.2 "Rear Panel."

Reference input

The instrument has an internal reference clock used for making measurements. However, a 10-MHz external signal can be applied to the REFERENCE IN terminal on the rear panel and can be used as the reference clock instead.

Reference output

The internal reference clock signal or the externally applied reference clock signal is passed through a 10-MHz band-pass filter and continuously output from the REFERENCE OUT terminal.

Monitor output

The signal applied to the input terminal is voltage divided to approximately half its value and output from this terminal.

This signal can be used to check the waveform when phase correcting a probe. Which channel's input signal is output varies depending on the measurement function.

External arming input/inhibit input

These signals are used to externally control the measurement functions of the instrument. The external arming input terminal is shared with the external gate input terminal. For the functions of the external arming or inhibit input signal, see section 1.5 "Acquisition Conditions for the Input Signal Being Measured."

Communication ≡See the "GP-IB Interface User's Manual" (IM704310-12E).≡

The GP-IB Interface comes standard with the instrument. The measured data can be transferred to a PC for analysis or an external controller can be used to control the instrument.

Storing and Recalling Setup Information

≡See chapter 10 for the operating procedures≡

Up to 10 sets of setup information can be stored in the internal non-volatile memory. The stored information can also be recalled to set up the instrument. This function is useful when the same setup is used often.

Saving and Loading Data from Floppy Disks, the Internal Hard Disk, and External SCSI Devices ≡See chapter 11 for the operating procedures≡

The floppy disk (FD) drive comes standard with the instrument. An internal hard disk can be installed as an option.

The setup information or measured data can be stored and loaded whenever it is necessary. You can also save an image of the screen in TIFF, BMP, or PostScript format. You can create reports by pasting the screen image data to a document created using a word processor.

Initialization of Setup Information ≡See chapter 13 for the operating procedures≡

The setup information can be reset to their factory default settings.

Calibration

≡See 13.2 for the operating procedures≡

Using the internal calibration signal, the offset voltage of the input amplifier and the conversion factors of the time and voltage converters can be calibrated. Calibrate the instrument when the ambient environment (temperature and humidity) changes drastically.

Beep and Click Sounds ≡See 13.5 for the operating procedures≡

A beep sound is heard when an error occurs. You can turn OFF this beep sound. You can also select to turn ON or OFF the click sound that is heard when the rotary knob is turned.

Error Logging ≡See 14.3 for the operating procedures≡

When a data error such as a data overflow or a communication error occurs, a ! mark is displayed in the upper right corner of the screen. In such instance, the error message is logged. You can review these messages later.

Self-test ≡See 14.4 for the operating procedures≡

If you are in doubt as to whether the instrument has malfunctioned, you can run a self-test before contacting a YOKOGAWA dealer. You can run checks on the circuit board, the keys, the display, and other functions.

Inter-symbol Interference Analysis Function (Option)

≡See chapter 9 for the operating procedures≡

The data around the spaces and marks of the specified condition can be extracted. The data can be displayed in a histogram format or their statistics can be calculated. In addition, the histograms and statistics of all marks and spaces of the measured data can be displayed at the same time.

Note that inter-symbol interference analysis can only be performed on pulse width measurements in the time stamp mode when the polarity setting is .

Analysis Example (Extracting the mark data before the 3T space)

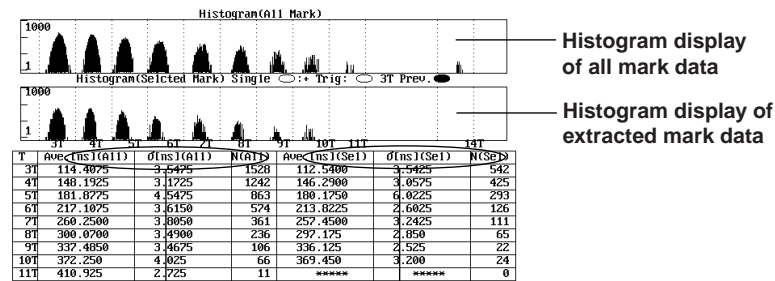
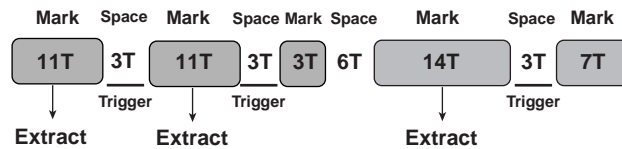

Statistics of the extracted mark data
Statistics of all mark data

2.1 Front Panel

- MODE key:** Select the sampling mode (Section 5.1).
- FUNCTION key:** Select the measurement function (Section 5.2 to 5.4).
- SAMPLE key:** Set gate, block sampling, arming, inhibit, and reference clock (Chapter 6).
- INPUT key:** Set input coupling, input impedance, and trigger mode (Section 6.6, 6.7).
- DISPLAY key:** Set the display format, calculation, and multi-window (Chapter 7).
- SCALE key:** Set the manual scaling (Section 7.7, 8.8).
- MARKER key:** Set the read-out marker (Section 7.8, 8.9).
- UTILITY key:** Initialize setup, store and recall from internal memory, etc (Chapter 10, 13).
- INITIALIZE key:** Initialize setup (Section 13.1).
- FILE key:** Save and load data from a medium (Chapter 11).
- AUTO SCALE key:** Execute auto scaling (Section 7.7, 8.8).
- COPY key:** Copy to the specified device (Chapter 12).
- LOCAL key:** Release remote mode.
- COPY MENU key:** Set copy (Chapter 12).

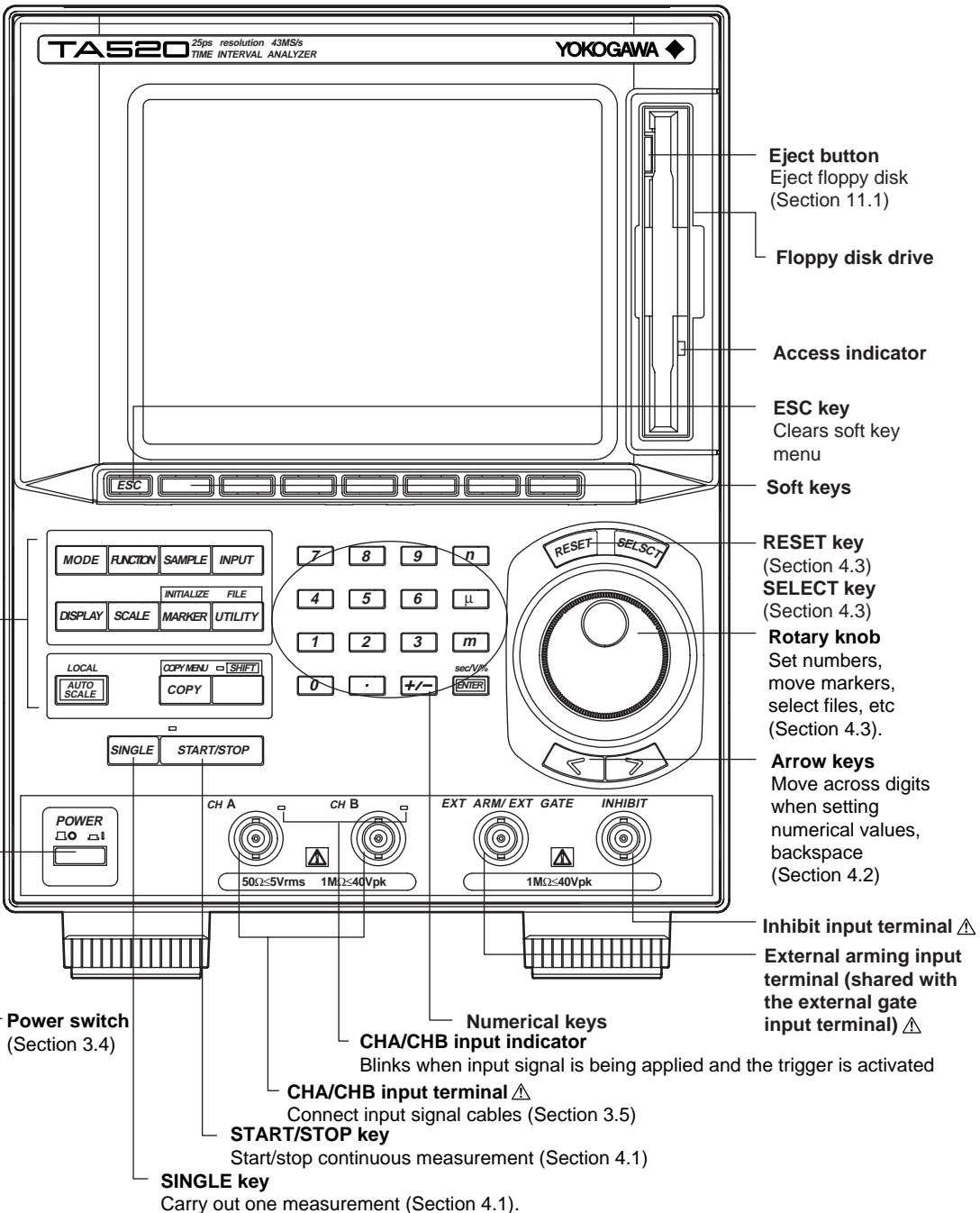

2.2 Rear Panel

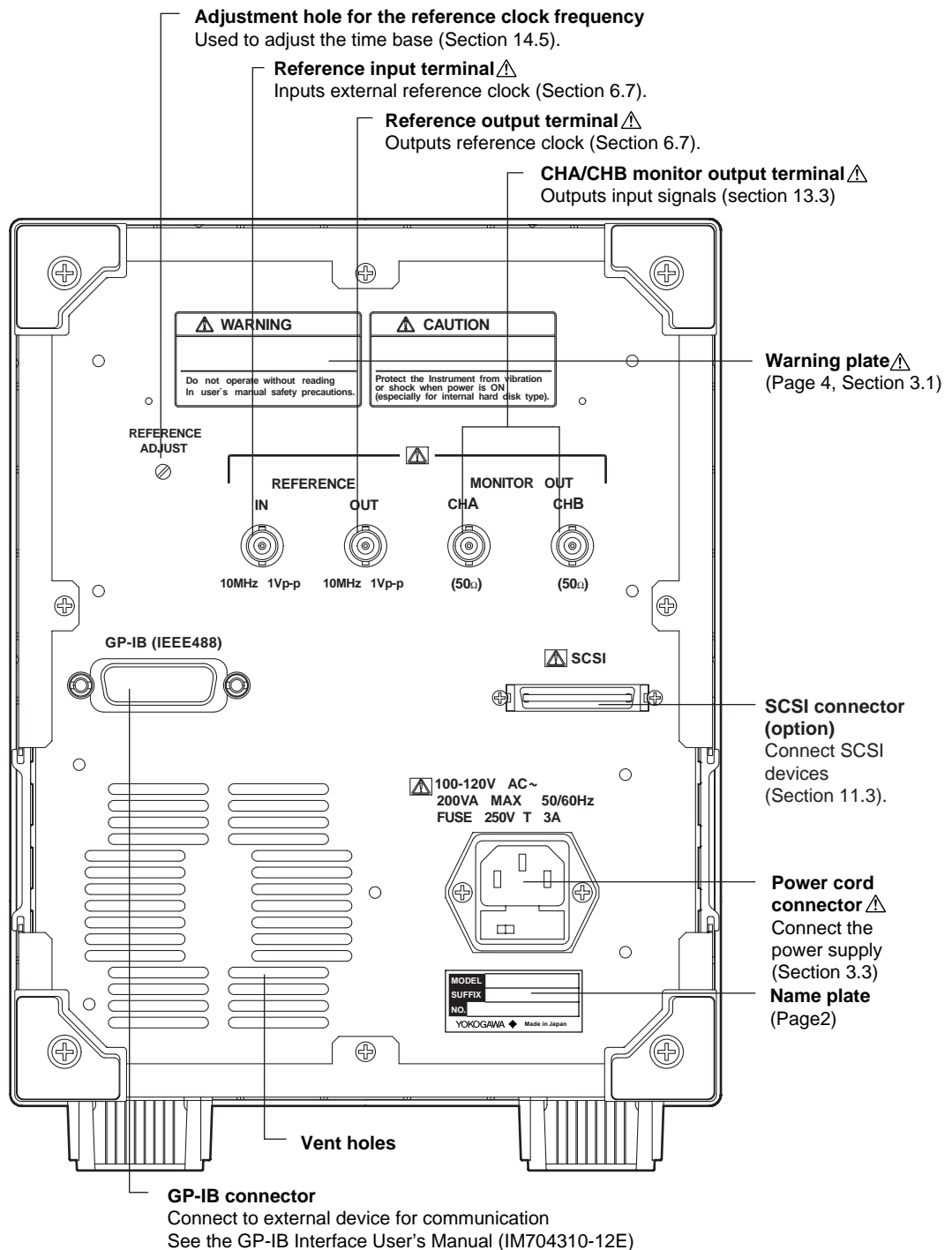

2.3 Screen Display

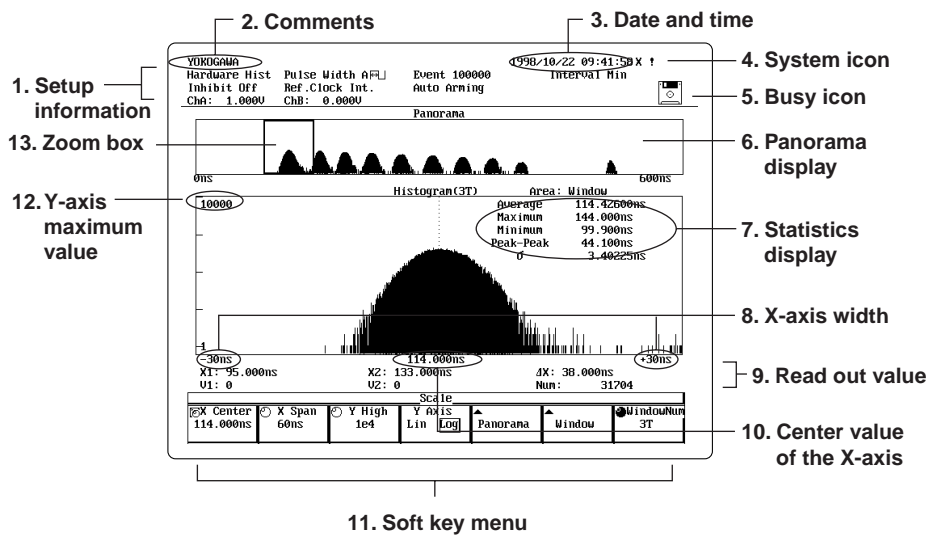

1. Setup information

Displays the conditions for measuring the data (sampling mode, measurement function, etc.).

2. Comments

Displays the comment that is added to the screen image data when they are printed such as on the internal printer.

3. Date and time (See section 3.7)

4. System icon

Displayed when there is a message or when the system is abnormal.

 : Displayed when there is a error message or a warning message (see section 14.3).

 : Displayed when the lithium battery is dead or the system is abnormal. Perform the self-test when this icon is displayed (see section 14.4).

5. Busy icon

Displayed during the following operations.

 : Blinks while accessing a medium.

 : Blinks while printing to the internal printer.

 : Blinks while processing data.

 : Blinks while detecting SCSI devices.

6. Panorama display (see sections 7.5 and 8.4)

7. Statistics display

The statistics can be displayed with the histogram or the time variation display.

8. X-axis width (X Span)

You can set the window range to display.

2.3 Screen Display

9. Read out value

Displays the read-out values of the X1 and X2 markers.

10.Center value of the X-axis

You can set the center value of the X-axis of the histogram display.

11.Soft key menu

Corresponds to the soft key on the front panel.

12.Y-axis maximum value

You can set this value for the log scale and linear scale.

13.Zoom box

The waveform in the zoom box is displayed zoomed in the main window.

3.1 Precautions on the Use of the instrument

Safety Precautions

- If you are using this instrument for the first time, make sure to thoroughly read the “Safety Precautions” given on page 4.
- Do not remove the cover from the instrument
Some sections inside the instrument have high voltages that are extremely dangerous. For internal inspection or adjustment, contact your nearest YOKOGAWA dealer.
- Never continue to use the instrument if there are any symptoms of trouble such as strange smells or smoke coming from the instrument. In such cases, immediately turn OFF the power and unplug the power cord. Then, contact your nearest YOKOGAWA dealer.
- If the following error message is displayed, immediately turn OFF the power. The cooling fan has stopped. From the rear panel, check for and remove any foreign object that may be obstructing the cooling fan. If the same error message appears when you turn ON the power switch again, it is probably a malfunction. In this case, contact your nearest YOKOGAWA dealer.

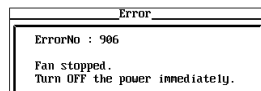

- Nothing should be placed on top of the power cord. The power cord should also be kept away from any heat sources. When unplugging the power cord from the outlet, never pull the cord itself. Always hold the plug and pull it. If the power cord is damaged, contact your dealer for replacement. Refer to page 2 for the part number when placing an order.

3.1 Precautions on the Use of the instrument

General Handling Precautions

- Never place any objects containing water on top of the instrument. This may cause problems.
- Do not apply shock or vibration to the instrument. It can lead to malfunction. Take extra care when dealing with the internal floppy disk drive and the internal hard disk (option), because they are prone to shock and vibrations. In addition, applying shock to the input terminal or the connected cable can cause electrical noise to enter the instrument.
- Do not bring charged objects near the input/output terminals. This can damage the instrument.
- When the instrument is not being used for an extended period of time, unplug the power cord from the outlet.
- When carrying the instrument, be sure to first disconnect the power and measurement cables. The instrument weighs 5 kg. To carry the instrument, use the handle as shown in the figure below, and move it carefully.

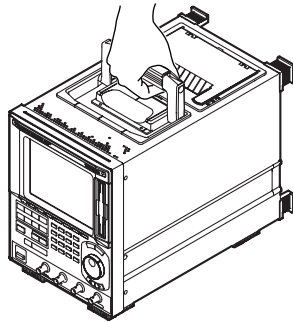

- Be careful not to scratch the surface of the LCD with sharp objects. It can lead to malfunction.
- When cleaning the case or the operation panel, first remove the power cord from the outlet. Then, wipe with a dry, soft cloth. Do not use volatile chemicals since this might cause discoloring and deformation.

3.2 Installing the Instrument



WARNING

To avoid the possibility of fire, never use the instrument with the rear side facing down, as the cooling vents will be obstructed. Placing the instrument with the rear side down can cause a fire when the instrument malfunctions. If you must use the instrument in this position, place a metal plate or a flame-resistive barrier (grade UL94-1 or higher) beneath the instrument.

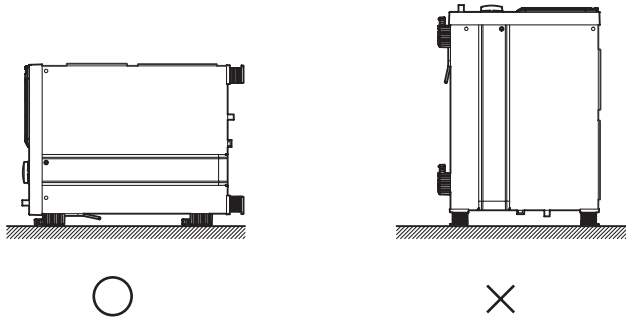

Installation condition

Install the instrument in a place that meets the following conditions.

Ambient temperature and humidity

Use the instrument in the following environment.

Ambient temperature: 5 to 40°C

For highly accurate measurements, the temperature should be $23\pm 2^\circ\text{C}$.

Ambient humidity: 20 to 80%RH (no condensation)

For highly accurate measurements, the humidity should be $50\pm 10\%$.

Note

Internal condensation may occur if the instrument is moved to another place where both the ambient temperature and humidity are higher, or if the temperature changes rapidly. In this case, let the instrument adjust to the new environment for at least one hour before using the instrument.

Well-ventilated location

Vent holes are located on the top and bottom of the instrument. In addition, vent holes for the cooling fan are located on the rear. To prevent internal overheating, allow enough space around the instrument (see the figure below) and do not block the vent holes.

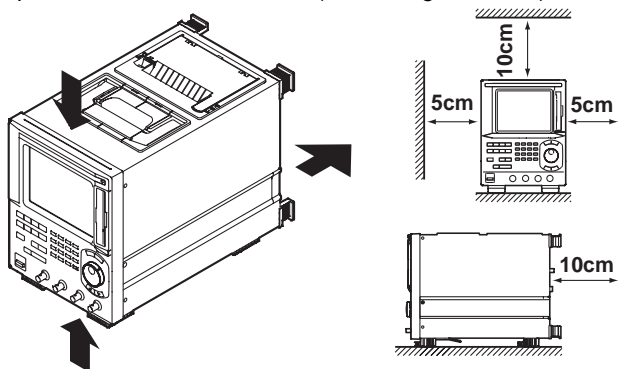

3.2 Installing the Instrument

Do not install the instrument in the following places:

In direct sunlight or near heat sources.

Near high voltage equipment or power lines.

Where an excessive amount of soot, steam, dust, or corrosive gases are present.

Near strong magnetic field sources.

Where the level of mechanical vibration is high.

In an unstable place.

Installation position

Place the instrument in a horizontal position or inclined position using the stand as shown in the figure below. When using the stand, pull it forward until it is vertical to the bottom side of the instrument and lock it. If you are placing the instrument on a slippery surface, attach rubber feet (two pieces, included in the package) on the rear feet. If you are not using the stand, return it to the original position while pressing it inward.

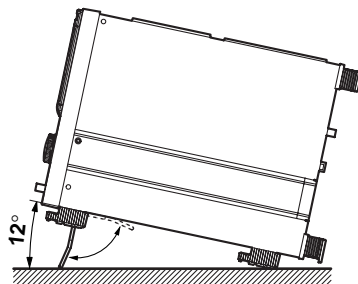

Rack Mounting

Rack mount kits are sold separately.

For mounting instructions, see the instruction manual that is supplied with the kit.

Name	Model	Description
Rack mount kit	751533-E6	For EIA single mount
Rack mount kit	751534-E6	For EIA dual mount
Rack mount kit	751533-J6	For JIS single mount
Rack mount kit	751534-J6	For JIS dual mount

3.3 Connecting the Power Cord

Before connecting the power

Follow the warnings below to avoid electric shock and damage to the instrument.



WARNING

- Connect the power cord only after confirming that the voltage of the power supply matches the rated electric power voltage for the instrument.
- Connect the power cord after checking that the power switch of the instrument is turned OFF.
- To prevent electric shock or fire, always use the power cord supplied by YOKOGAWA.
- Always use protective grounding to prevent electric shock. Connect the power cord of the instrument to a three-pole power outlet that has a protective grounding terminal.
- Never use an extension cord that does not have protective grounding, otherwise the protection function will be compromised.

Connecting Procedure

1. Check that the power switch on the front panel is OFF.
2. Connect the plug of the accessory power cord to the power connector on the rear panel of the instrument.
3. Plug the other end of the power cord into a power outlet that satisfies the conditions below. The AC outlet must be a three-pole type that has a protective grounding terminal.

Item	Suffix-1	Suffix-5
Rated supply voltage	100 to 120 VAC	200 to 240 VAC
Permitted supply voltage range	90 to 132 VAC	180 to 264 VAC
Rated supply voltage frequency	50/60 Hz	50/60Hz
Permitted supply voltage frequency range	48 to 63 Hz	48 to 63 Hz
Maximum power consumption	200 VA	200 VA

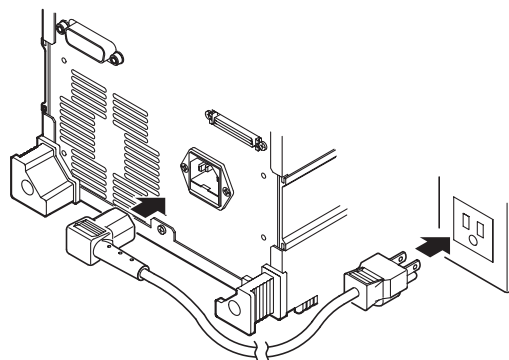

3.4 Turning the Power Switch ON/OFF

Points to Check before Turning ON the Power

Is the instrument properly installed? See section 3.2 "Installing the Instrument."

Is the power cord properly connected? See section 3.3 "Connecting the Power Cord."

Location of the Power Switch and ON/OFF Operation

The power switch is located on the lower left corner of the front panel. To turn the power ON, press the switch once. To turn the power OFF, press it again.

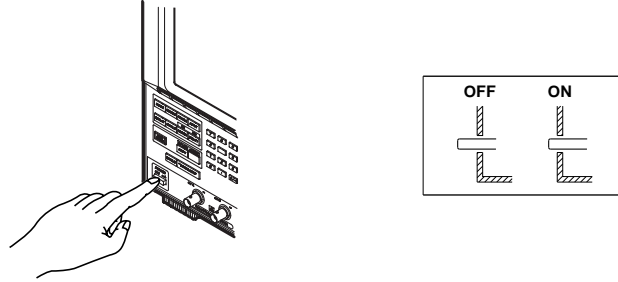

Power Up Operation

When the power is turned ON, the instrument executes the following initialization checks. The front operation panel is disabled during the check. When the initialization completes, the display format screen (the screen that is displayed when the DISPLAY key is pressed) appears.

- ROM Check
- SRAM Check
- DRAM Check
- SRAM Cal Check : Calibration data check
- Device Check: Internal hardware check

Note

If the instrument fails to power up as described, turn OFF the power switch and check the following points.

- Is the power cord securely connected?
- Is the correct voltage coming to the power outlet? See section 3.3.

If the instrument still fails to power up after checking these points, the instrument probably has malfunctioned. Contact your nearest YOKOGAWA dealer.

For Making Accurate Measurements

Under the installation conditions described in 3.2, turn ON the power switch and allow the instrument to warm up for at least 30 minutes before starting measurements.

Shut Down Operation

When the power switch is turned OFF, the setup information is retained, but the measured data are not. Make sure to save important data to the floppy disk before turning OFF the power.

Note

The lithium battery that is used to retain information has a finite life. When the battery approaches the end of its life, the instrument begins to operate abnormally such as indicating an incorrect date and time or failing to save or load measured data. If you see these symptoms, please perform the self-test according to "14.4 Performing a Self-test." If the "Low Battery" warning message is displayed, the lithium battery must be replaced immediately. Because the batteries cannot be replaced by the user, contact your nearest YOKOGAWA dealer.

3.5 Connecting Cables and Probes

Location of the Input Terminals

The input terminals are located on the lower section of the front panel. Connect a cable with a BNC connector or a probe.

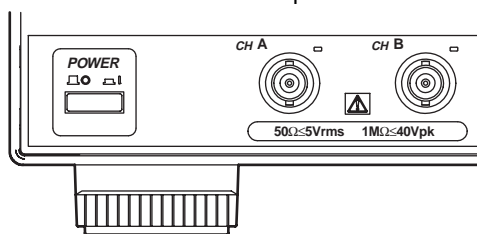

Input Specifications

- Connector type : BNC
 Number of channels : 2
 Input impedance : 50 Ω/1 MΩ, 20 pF(Typical value*)
 Maximum input voltage
- When the input impedance is 50 Ω : 5Vrms
 - When the input impedance is 1 MΩ:
 - 40 V (DC+ACpeak) when $DC \leq \text{input frequency} \leq 100 \text{ kHz}$
 - $\{3.5/f+5\}V(DC+ACpeak)$ when $100 \text{ kHz} \leq \text{input frequency} \leq 200 \text{ MHz}$, where f is a frequency in MHz.
- Ground : Connect to the case's ground

* Typical values represent typical or average values. They are not strictly guaranteed.



CAUTION

Do not apply a voltage exceeding the maximum input voltage to the input terminals. It can damage the input section.

Note

If you are using the probe for the first time, perform phase correction according to "3.6 Calibrating the Probe (Performing Phase Correction)." If the probe is not calibrated, the gain will not be constant across different frequencies and proper measurements cannot be made. Perform phase correction for each channel.

3.6 Calibrating the Probe (Performing Phase Correction)

Equipment Required

Prepare the following equipment

Calibration signal

Frequency	: 1 kHz
Voltage (amplitude)	: 1 V _{p-p}
Waveform type	: Square wave
Output impedance	: 1 M Ω
Recommended signal	: CAL signal of YOKOGAWA DL1500 Series Digital Oscilloscope

Waveform monitor

Frequency characteristics	: DC to 200 MHz(–3 dB attenuation point)
Input coupling	: DC
Input impedance	: Connect a 50 Ω terminator to the input terminal of the waveform monitor.
Recommended device	: YOKOGAWA DL1500 Series Digital Oscilloscope +50 Ω terminator (YOKOGAWA 700976)

The following section describes the connection and operating procedures when the recommended signal and device are used.

Connecting Devices



CAUTION

- Do not apply a voltage exceeding the maximum input voltage to the input terminals. It can damage the input section.
- Do not apply external voltage to the CAL signal output terminal of the DL1500 Series or to the monitor output terminal of this instrument. It can damage the internal circuitry.

Check that this instrument and the DL1500 Series Oscilloscopes are turned OFF. Then, connect them as shown below.

1. Use a BNC cable to connect the monitor output terminal on the rear panel of the instrument (for CHA and CHB) and the input terminal of the DL1500 Series oscilloscope.
2. Connect the BNC connector of the probe that you are calibrating to the input terminal of the instrument.
3. Connect the other end of the probe to the CAL signal output terminal of the DL1500 Series oscilloscope, and the grounding wire to the functional grounding terminal.

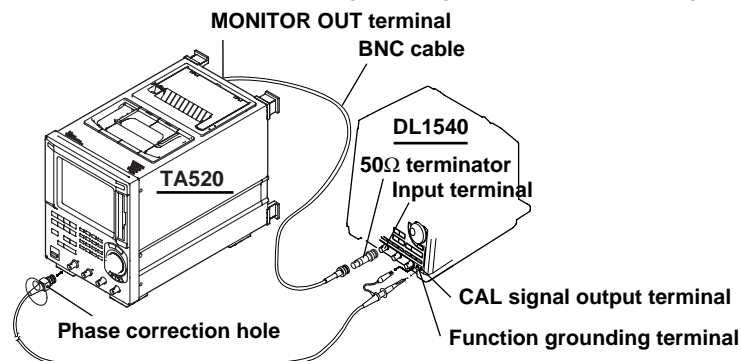

Procedure

1. Turn ON this instrument and the DL1500 Series oscilloscope.
2. Set the waveform acquisition conditions on the DL1500 Series oscilloscope so that approximately two periods of the waveform are displayed clearly on the screen. For the procedures, see the User's Manual for the DL1500 Series.
3. Insert a screwdriver into the probe's phase correction hole and turn the variable capacitor so that the displayed waveform on the monitor becomes a proper square wave (see explanation).

Explanation**Necessity of probe phase correction**

If the input capacitance of the probe is not within the appropriate range, the gain will not be constant across different frequencies and proper waveforms cannot be input to the instrument. However, the input capacitance of each probe is not necessarily the same. Thus, a variable capacitor (trimmer) is attached to the probe for making adjustments. This adjustment is called phase correction.

Perform phase correction on all probes that are to be used for the first time. Since the appropriate input capacitance varies for different channels, phase correction must also be performed when changing channels.

Calibration signal

Waveform type : Square wave

Frequency : 1 kHz

Voltage : 1 Vp-p

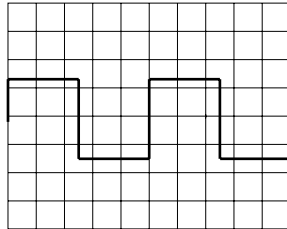
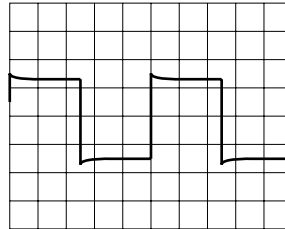
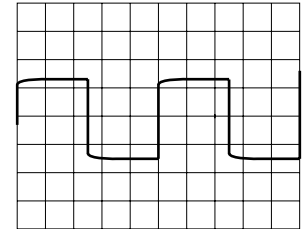
Waveform differences due to probe's phase correction**Correct waveform****Over-compensated (the gain at the high frequency region is too large)****Under-compensated (the gain at the high frequency region is too small)**

3.7 Setting the Date and Time

Procedure

1. Press the UTILITY key to display the Utility menu.
2. Press the [Config] soft key to display the Configuration menu.

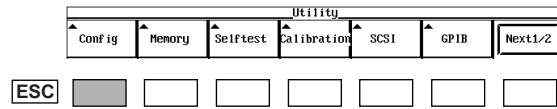

Setting the date

3. Press the [Date] soft key to display the Date menu.

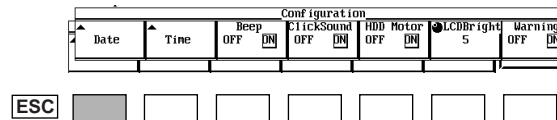

4. Press the [Year], [Month], and [Day] soft keys, and set the date with the rotary knob.
5. Pressing the [Set] soft key updates the date.

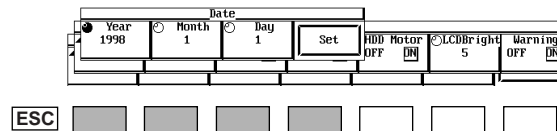

Setting the time

3. Press the [Time] soft key to display the Time menu.

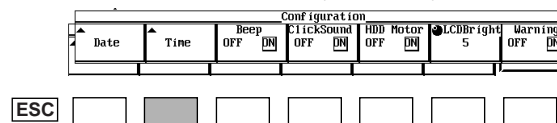

4. Press the [Hour] and [Minute] soft keys, and set the time with the rotary knob.
5. Pressing the [Set] soft key updates the time.

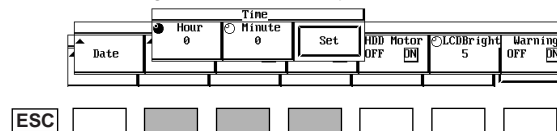

Explanation**Setting the date**

Set the year, month, and day.

- Year
Selectable range: 1998 to 2047
- Month
Selectable range: 1 to 12
- Day
Selectable range: 1 to 31

Setting the time

Set the hour and minute.

- Hour
Selectable range: 0 to 23
- Minute
Selectable range: 0 to 59
The seconds are displayed on the screen, but they cannot be set. The seconds will be set to 00 s when the [Set] soft key is pressed.

Location of the date and time displays

The date and time are displayed at the upper right section of the screen.

4.1 Starting and Stopping the Acquisition of an Input Signal

Procedure



When measuring continuously

- Starting the measurement
Press the START/STOP key to start the measurement. The measurement indicator lights.
- Stopping the measurement
Press the START/STOP key to stop the measurement. The measurement indicator turns off.

When measuring once

Press the SINGLE key. The measurement stops automatically after making one measurement. The measurement indicator lights while the measurement is in progress and turns off when the measurement completes.

Explanation

Continuous measurement

Once the measurement is started, it continues until the START/STOP key is pressed again.

Single measurement

A single measurement is made every time the SINGLE key is pressed.

Note

- One set of measurements is called one block (see section 1.5). However, when using block sampling, [1 block x the number of blocks] is one set of measurements.
- If the START/STOP key is pressed in the middle of a measurement block and the measurement is aborted, the measured data are acquired up to that point and the measurement stops.
- There are input indicators for CHA and CHB above the input terminals. If this indicator is not blinking, the signal may not be entering the instrument. Check the trigger level setting (see section 6.6), the cable connection, and the signal source. If the signal is properly entering the input terminal of the instrument, but the CHA/CHB input indicator is not blinking, then there may be a malfunction. Contact your nearest YOKOGAWA dealer to have it fixed.

4.2 Setting Numerical Values and Strings

Procedure

Entering a numerical value using the numerical keys

If the Ⓢ mark is displayed on the soft key, you can use the numerical keys to set the numerical value.

1. Press the numerical keys to enter a numerical value.
2. Pressing a unit key or ENTER key confirms the value.

This box appears when entering values with the numerical keys.

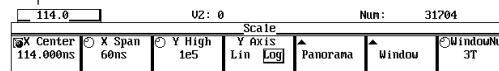

Canceling the numerical value set with the numerical keys

2. Pressing the RESET key before the value is confirmed cancels the value that is being set.

Setting a numerical value using the rotary knob

If the Ⓢ mark or the Ⓢ mark is displayed on the soft key, you can use the rotary knob to set the value.

1. Move the cursor to the desired digit using the arrow keys (⏪ ⏩).
2. Turn the rotary knob to select the desired value.

Setting a string (keyboard operation)

1. Turn the rotary knob to highlight the desired character.
If a string is already entered, such as a file name, move the cursor to the desired position using the arrow keys.
2. Pressing the SELECT key, confirms the input character.
3. Repeat steps 1 and 2 to enter all the characters.
4. Moving the cursor to [ENT] on the keyboard and pressing the SELECT key confirms the string and the keyboard disappears.

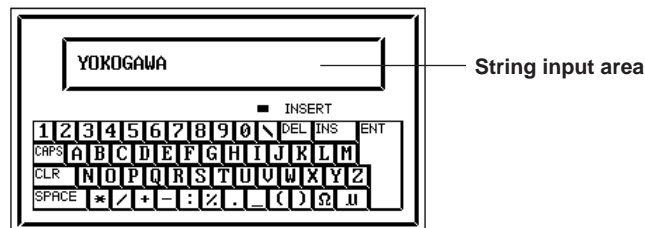

Explanation**Setting a numerical value using the numerical keys**

If you press another key before pressing a unit key or the ENTER key, the value that you were setting is not confirmed and it is set back to the value that existed before.

You can cancel a value by pressing the RESET key before the value is confirmed.

Setting a numerical value using the rotary knob

Only numerical values can be set with the rotary knob. You cannot set the unit with the rotary knob as you can with the numerical keys.

If the value of the digit at the cursor position is increased using the rotary knob, the value is carried over to the next digit. If the value is decreased, the opposite occurs.

Setting the string

For file names and comments, the keyboard that pops up on the screen is used to set the string.

- **Keys other than the character keys on the keyboard**

DEL : Deletes the character immediately before the cursor.

INS : Switches the insert/overwrite mode. During the insert mode, the INSERT indicator on the keyboard lights.

CLR : Clears all characters that are displayed.

SPACE : Enters one space.

ENT : Confirms the string that is displayed.

CAPS : Switches the case of the input character.

- **The number and types of characters that can be used on file names and comments.**

	Number of characters	Allowed characters
File name	1 to 8 characters	0 to 9, A to Z, – (minus), %, _, (,)
Comment	0 to 25 characters	All characters (includes space)

Arrow keys

The operation varies depending on the method used to input the numerical values.

- When using the numerical keys
Operates as a backspace key.
- When using the rotary knob
Moves along the digits.
- When using the keyboard
Moves the cursor in the string input section.

Note

- You can reset the numerical values to their factory default values. For details, see section 13.1. However, be careful, because all values are reset.

When using the numerical keys

- Even if you try to set numbers beyond the resolution of each item, they are cut off.
- If you try to set a value that exceeds the maximum value or a value that falls short of the minimum value, they are set to the maximum and minimum values, respectively.

When using the keyboard

- You can use the keyboard along with the numerical keys. The numerical keys that can be used are as follows.
0 to 9, ., ENTER, RESET key (keyboard's CLR operation)
- Upper and lower case letters are not distinguished for file names. Comments distinguish them. In addition, the following five file names cannot be used due to the limitation of MS-DOS.
AUX, CON, PRN, NUL, CLOCK
- When using the GP-IB interface commands to enter a file name, the following symbols that do not exist on the keyboard of this instrument can be used.
! # \$ ' - ^ @ ~ { }

4.3 The Way to Look at the Soft Key Menu/Using the Rotary Knob and Select Key

The way to look at the soft key menu

▲ : Pressing this soft key causes a menu to pop up.

⊗ : You can set the value using both the numerical keys and the rotary knob.

⊙ : You can set the value or select the setting item using the rotary knob.

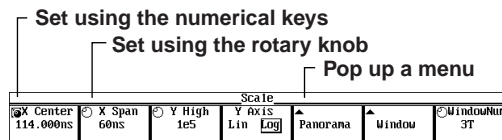

Using the rotary knob and SELECT key

In a setting screen as shown below, values are set using the rotary knob and SELECT key.

- **When selecting an item**

Move the cursor to the desired item using the rotary knob and press the SELECT key to select the item.

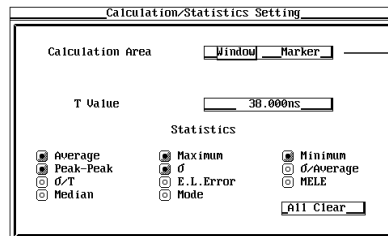

1. Use the rotary knob to move the cursor to the desired item.
2. Select the item using the SELECT key.

- **When setting a numerical value**

Move the cursor to the desired item using the rotary knob, and press the SELECT key to display the numerical value input area, and enter the value using the numerical keys.

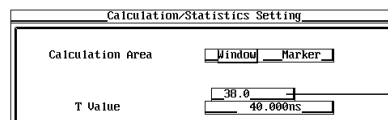

Press the SELECT key to display the numerical input area, then enter the value using numerical keys.

- **When checking a box**

Move the cursor to the desired item using the rotary knob, press the SELECT key to check or uncheck the box.

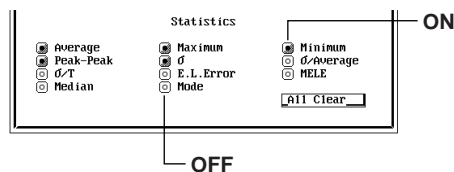

Using the ESC key

Press this key to exit the current menu (go back one menu).

Using the RESET key

Use this key to cancel the numerical value that was entered using the numerical keys.

5.1 Selecting the Sampling Mode

≡For a functional description, see 1.3.≡

Procedure

1. Press the MODE key to display the MODE menu.

When selecting the time stamp mode

2. Press the [TimeStamp] soft key.

When selecting the hardware histogram mode

2. Press the [HardHist] soft key.

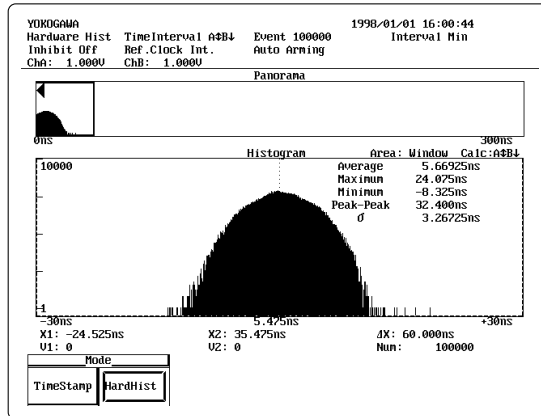

Explanation

Selecting the sampling mode

Select from the following choices.

- Time stamp mode : Acquires the measured values and their time stamps to the acquisition memory.
- Hardware histogram mode : Acquires the measured values and the frequency of occurrence of those values to the acquisition memory.

Note

If you change the sampling mode or the measurement function, the data acquired up to that point can no longer be displayed or analyzed. Acquire the data again, or load the data from a file.

5.2 Setting the Period Measurement

≡For a functional description, see 1.4.≡

Procedure

1. Press the FUNCTION key to display the Function menu.
2. Press the [Function] soft key.

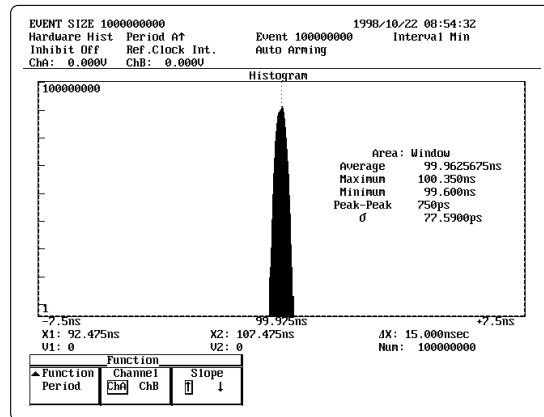

Selecting period measurement

3. Press the [Period] soft key.

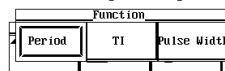

Selecting the channel to be measured

4. Press the [Channel] soft key and select [ChA] or [ChB].

Selecting the slope

5. Press the [Slope] soft key and select [↑] or [↓].

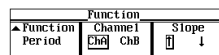

Explanation

Measurement range

The measurement range varies depending on the sampling mode.

- For time stamp mode : 8 ns to 20 ms
- For hardware histogram mode : 8 ns to 3.2μ s

Selecting the channel to be measured

Select either CHA or CHB.

Selecting the slope

Select from the following choices.

- ↑: Measures from a rising edge to the next rising edge of the input signal.
- ↓: Measures from a falling edge to the next falling edge of the input signal.

Note

If you change the sampling mode or the measurement function, the data acquired up to that point can no longer be displayed or analyzed. Acquire the data again, or load the data from a file.

5.3 Setting the Time Interval Measurement

≒For a functional description, see 1.4.≒

Procedure

1. Press the FUNCTION key to display the Function menu.
2. Press the [Function] soft key.

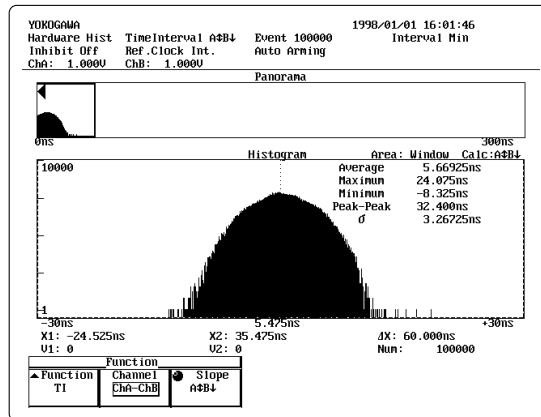

Selecting time interval measurement

3. Press the [TI] soft key.

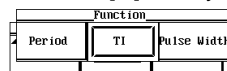

Selecting the slope

4. Turn the rotary knob to select the slope.

Explanation

Measurement range

The measurement range varies depending on the sampling mode.

- For time stamp mode : 0 ns to 20 ms
- For hardware histogram mode: 0 ns to 3.2 μs

Selecting the slope

- **A ↑ B ↑**: Measures the interval from a rising edge of CHA to the first rising edge of CHB.
- **A ↑ B ↓**: Measures the interval from a rising edge of CHA to the first falling edge of CHB.
- **A ↓ B ↑**: Measures the interval from a falling edge of CHA to the first rising edge of CHB.
- **A ↓ B ↓**: Measures the interval from a falling edge of CHA to the first falling edge of CHB.
- **A ↑ B ↑**: Measures the interval from a rising or falling edge of CHA to the first rising edge of CHB. **A ↑ B ↑** and **A ↓ B ↑** are measured alternately. In addition, the measured data corresponding to **A ↑ B ↑** or **A ↓ B ↑**, and **A ↑ B ↓** can be separated for the purpose of displaying histograms and calculating statistics.
- **A ↑ B ↓**: Measures the interval from a rising or falling edge of CHA to the first falling edge of CHB. **A ↑ B ↓** and **A ↓ B ↓** are measured alternately. In addition the measured data corresponding to **A ↑ B ↓** or **A ↓ B ↓** and **A ↑ B ↓** can be separated for the purpose of displaying histograms and calculating statistics.

For the procedures related to displaying histograms for the separated data, see sections 7.1 and 8.1. For the procedures related to calculating statistics, see sections 7.6 and 8.7.

5.3 Setting the Time Interval Measurement

Example of separating the data and displaying the histogram

Select either one

1000000
-30ns
X1: -12
U1: 0

Calculation Area: Window, Marker
Calculation Slope: A4BT, A4BT, A4BT
T Value: 19.100ns

Statistics:
 Average
 Peak-Peak
 σ/T
 Median
 Maximum
 β
 E.L. Error
 Mode
 Minimum
 σ /Average
 MELE

All Clear

Item Histogram Style Calc/Stat ISI

YOKOGAWA
TimeStamp 1998/11/02 14:27:02
Inhibit Off TimeInterval A4BT Event 100000 Interval 0.0us
Ref.Clock Int. Auto Arming
ChA: 1.000V ChB: 1.000V

Histogram A4BT
1000000
-30ns
X1: -12.100ns X2: 47.900ns ΔX : 60.000ns
U1: 0

Displays A ↓ B ↑

Histogram A4BT
1000000
-30ns
X1: -12.100ns X2: 47.900ns ΔX : 60.000ns
U1: 0

Displays A ↓ B ↑ only

Graph Size: Half, Full
Statistics: OFF, ON
Marker: OFF, ON
Overlap: OFF, ON

Note

- Continuous measurements are possible if the period of CHA is 23 ns or more and the time between the slope of CHB and the slope of CHA is 13 ns or more.

A ↓ B ↑ Example

Continuously measures t2 when the period of CHA is 23 ns or more.

Measurement Measurement

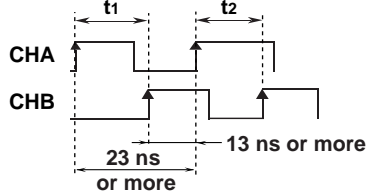

Measures t3 and not t2 when the period of CHA is less than 23 ns.

Measurement Measurement

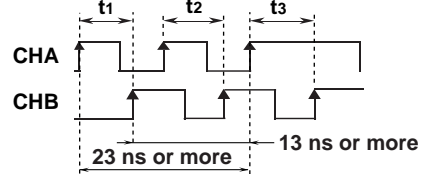

- If you change the sampling mode or the measurement function, the data acquired up to that point can no longer be displayed or analyzed. Acquire the data again, or load the data from the file.

5.4 Setting the Pulse Width Measurement

≡For a functional description, see 1.4.≡

Procedure

1. Press the FUNCTION key to display the Function menu.
2. Press the [Function] soft key.

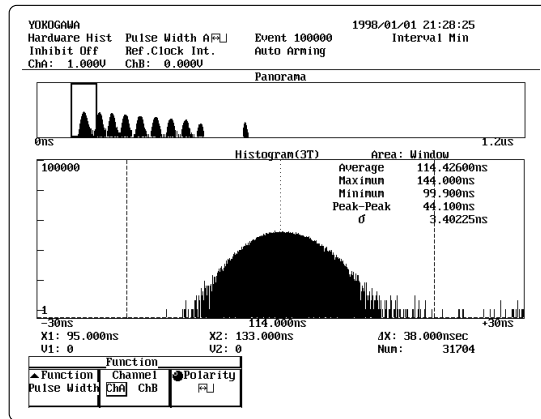

ESC

Selecting pulse width measurement

3. Press the [Pulse Width] soft key.

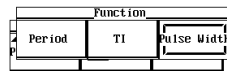

ESC

Selecting the channel to be measured

4. Press the [Channel] soft key and select [ChA] or [ChB].

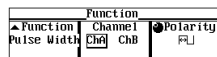

ESC

Selecting the polarity

5. Turn the rotary knob to select the polarity.

5.4 Setting the Pulse Width Measurement

Explanation

Measurement range

The measurement range varies depending on the sampling mode.







- For time stamp mode : 8 ns to 20 ms
- For hardware histogram mode : 8 ns to 3.2μs

Selecting the channel to be measured

Select either CHA or CHB.

Selecting the polarity

Select from the following choices.

-  : Measures the positive side (from a rising edge to the next falling edge).
-  : Measures the negative side (from a falling edge to the next rising edge).
-  : Measures the positive and negative sides alternately. In addition the measured data corresponding to  or  and  can be separated for the purpose of displaying histograms. For details see sections 7.1 and 8.1.

Example of separating the data and displaying the histogram

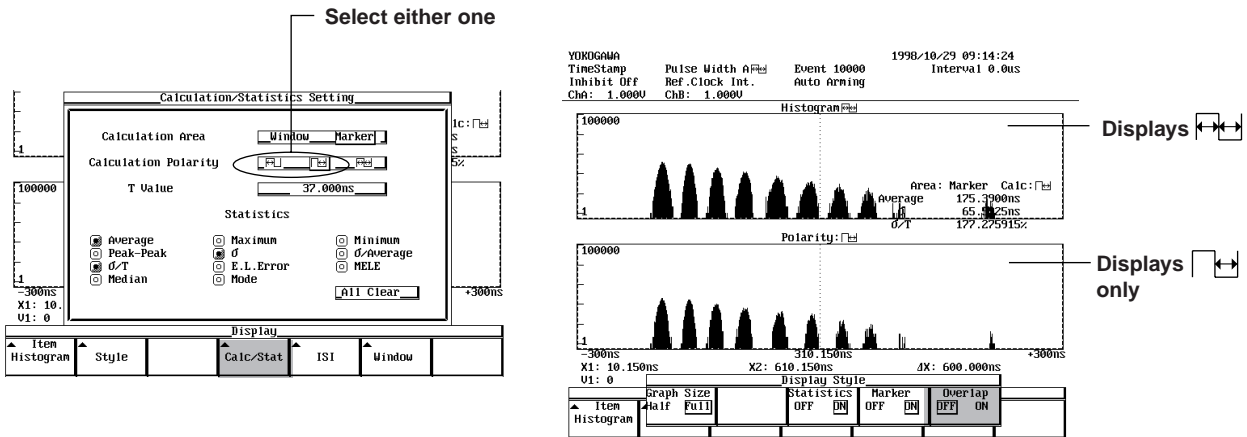

Note

If you change the sampling mode or the measurement function, the data acquired up to that point can no longer be displayed or analyzed. Acquire the data again, or load the data from a file.

6.1 Setting the Gate

≒For a functional description, see 1.5.≒

Procedure

1. Press the SAMPLE key to display the Sample menu.
2. Press the [GateMode] soft key to display the Gate Mode menu.

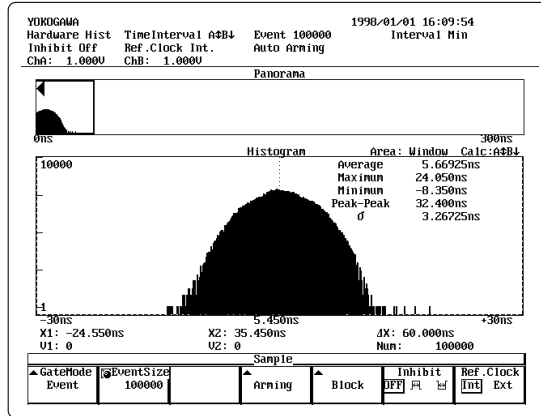

ESC

Selecting the gate mode

3. Press the soft key corresponding to the desired gate mode.

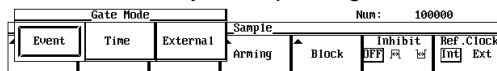

ESC

When event gate (Event) is selected

4. Use the rotary knob or the numerical keys to set the number of events (Event Size).

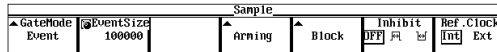

ESC

When time gate (Time) is selected

4. Use the rotary knob or the numerical keys to set the gate time.



ESC

When external gate (External) is selected

4. Press the [Polarity] soft key to select the polarity.

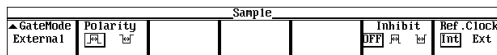

ESC

Explanation

Selecting the gate mode

Select from the following choices.

- **Event** : Set the size (range) of a measurement block by specifying the number of events.
- **Time** : Set the size (range) of a measurement block by specifying a period of time.
- **External** : Set the size (range) of a measurement block using the external gate. Since the external gate input terminal is shared with the external arming input terminal, selecting external gate will prevent the use of external arming.

When [External] is selected

Apply a signal to the terminal marked [EXT ARM/EXT GATE] on the front panel. (The terminal is shared with external arming.)

- **Input impedance** : 1 MΩ (Typical value*)
- **Input coupling** : DC
- **Gate level** : Select TTL (1.4 V), TTL/10 (0.14 V), or 0 V
- **Maximum input voltage** : 40 V (DC+ACpeak)
- **Minimum input pulse width** : 30 ns
- **Setup time** : 50 ns (For the gate to become effective, the gate signal must arrive at least 50 ns earlier than the measurement signal.)

* Typical values represent typical or average values. They are not strictly guaranteed.

External gate (shared with external arming) input circuit

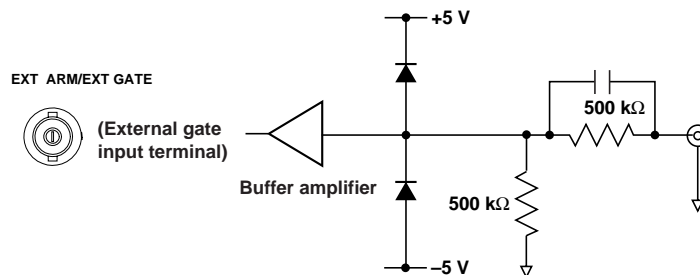

CAUTION

Applying a voltage exceeding the maximum input voltage to the external gate input terminals can damage the input section.

Selectable range for the number of events

The number varies depending on the sampling mode. This value can only be set when the gate mode is set to event gate.

- During the time stamp mode : 1 to 512,000
- During the hardware histogram mode : 1 to 10⁹

Note

- After arming, if the maximum sampling time elapses before the specified number of events is reached, then the measurement block stops at that point.
- The gate level is set using the INPUT key.

Selectable range for the gate time

The selectable range is as follows. This value can only be set when the gate mode is set to time gate.



1 μ s to 10 s (in 100 ns steps)

Note

If the number of events (samples) reaches the maximum number of events for the appropriate sampling mode before the specified gate time elapses, then the measurement block stops at that point.

Selecting the polarity

Select from the following choices. It is set only when the gate mode is set to external gate.

-  : Measures while a positive signal is being applied to the external gate input terminal (EXT ARM/EXT GATE)
-  : Measures while a negative signal is being applied to the external gate input terminal (EXT ARM/EXT GATE)

Note

- Even if the external gate is continuously open for a long period of time, the measurement block ends when the number of events reaches the maximum sampling size for the appropriate sampling mode or when the maximum sampling time elapses.
- When external gate is selected, block sampling is turned OFF and arming is set to Auto.

6.2 Setting the Sampling Interval

≡For a functional description, see 1.5.≡

Procedure

1. Press the SAMPLE key to display the Sample menu.

Selecting the sampling interval

2. Press the [Interval] soft key.
Use the rotary knob or the numerical keys to set the sampling interval.

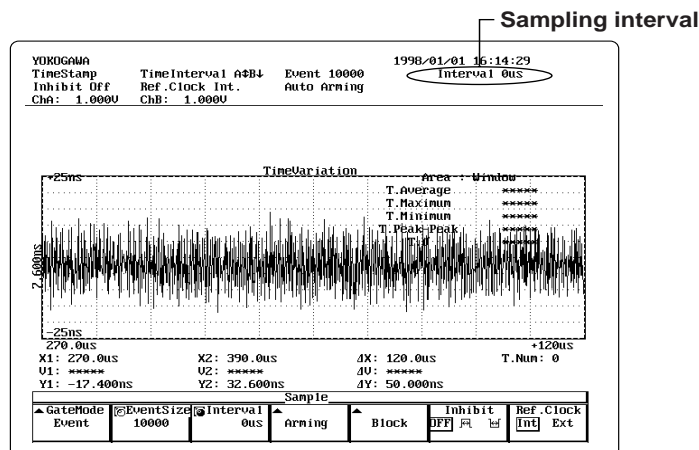

ESC

Explanation

The sampling interval is set only during the time stamp mode.

Setting the sampling interval

Select from the following choices. During the hardware histogram mode, it is fixed to 0 μ s and no menu is displayed.

0 μ s, 1 μ s to 1 s (in 1 μ s steps)

The sampling interval when 0 μ s is selected is approximately 23 ns.

Note

If the sampling interval is changed, the time resolution of the time stamp also changes as follows:

Sampling Interval	Time Resolution of the Time Stamp
0 μ s	100 ns
1 μ s to 1 s	1 μ s

6.3 Performing Block Sampling

≡For a functional description, see 1.5.≡

Procedure

1. Press the SAMPLE key to display the Sample menu.
2. Press the [Block] soft key to display the Block Sample menu.

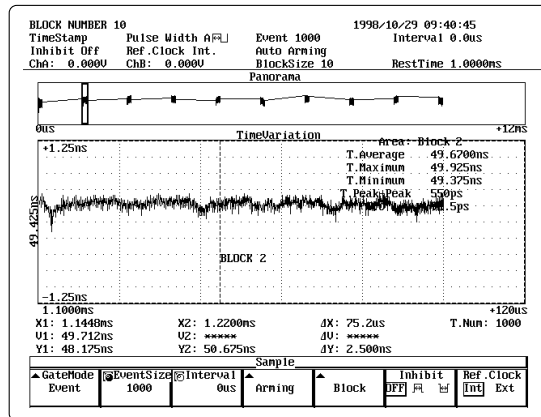

ESC

Performing block sampling

3. Press the [Mode] soft key and select [ON].

Set the number of blocks

4. Press the [BlockSize] soft key.
Use the rotary knob or the numerical keys to set the number of measurement blocks.

Select the pause mode

5. Press the [RestMode] soft key.
Turn the rotary knob to select the pause mode from [OFF], [Time], and [Event].

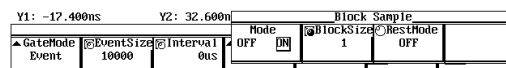

ESC

• When the pause mode is set to Time

6. Press the [RestTime] soft key.
Use the rotary knob or the numerical keys to set the pause time.

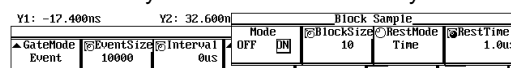

ESC

• When the pause mode is set to Event

6. Press the [RestEvent] soft key.
Use the rotary knob or the numerical keys to set the number of events to pause.

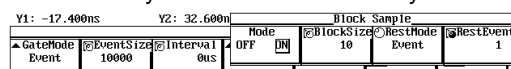

ESC

Explanation

The display format and analysis method of the block sampled data differ for the time stamp mode and the hardware histogram mode.

Time stamp mode

The instrument retains time stamps and measured values for each measurement block. You can display the time variation display, list display, and calculate statistics on each measurement block.

Hardware histogram mode

The instrument retains the measured values and the frequency of occurrence of those values by summing the data of all measurement blocks. You can not use the list display or calculate statistics on each measurement block.

Setting the number of blocks

- Time stamp mode : 1 to 100
- Hardware histogram mode : 1 to 1000

Setting the pause time

Select from the following choices.

OFF : No pause time

RestTime : Set the pause time in units of time
1.0 μ s to 1.0000000 s (in 100 ns steps)

RestEvent : Set the pause time by specifying the number of events
1 to 1000000

Note

- Block sampling is not possible when external gate is selected or when the inter-symbolic interference analysis function is being used.
 - When the pause time is set using the number of events and the pause time is less than 500 ns, it is set to 500 ns.
-

6.4 Setting the Arming Source, Slope, and Delay

≒For a functional description, see 1.5.≒

Procedure

1. Press the SAMPLE key to display the Sample menu.

Displaying the arming menu

2. Press the [Arming] soft key to display the Arming menu. When external gate is selected the arming menu is not displayed (the ARMING soft key is not displayed).

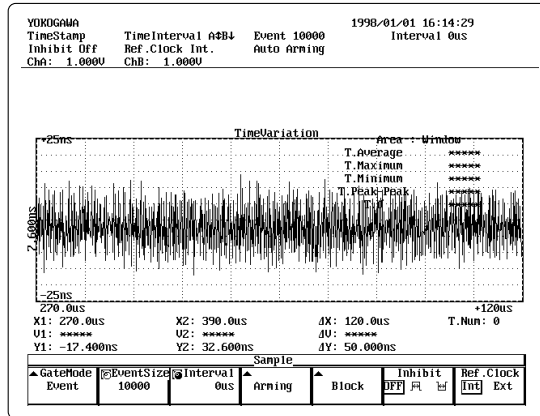

ESC

Selecting the arming source

3. Press the [Source] soft key and select [Auto] or [Ext].
If you select Ext (external arming) proceed to the following steps. If you select Auto (auto arming), then the following menu will not be displayed.

Selecting the slope (for external arming only)

4. Select the [Slope] soft key to select [\uparrow] or [\downarrow].

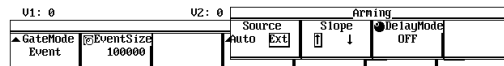

ESC

6.4 Setting the Arming Source, Slope, and Delay

Selecting the type of arming delay (for external arming only)

- Press the [DelayMode] soft key.
Turn the rotary knob to select [OFF], [Time], or [Event].

- **Set the delay time (when the type of arming delay is set to Time in step 5)**

- Press the [D.Time] soft key.
Use the rotary knob or the numerical keys to set the delay time.

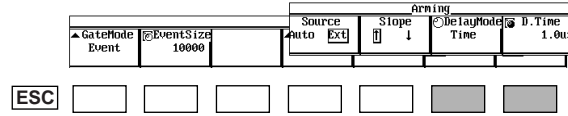

- **Set the number of events (when the type of arming delay is set to Event in step 5)**

- Press the [D.Event] soft key.
Use the rotary knob or the numerical keys to set the number of events.

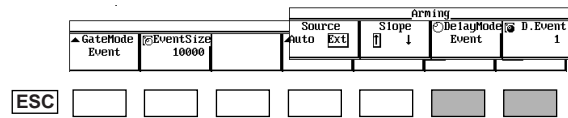

Selecting the arming level

- Press the INPUT key to display the Input menu.
- Press the [Setting] soft key to display the Input Setting menu.

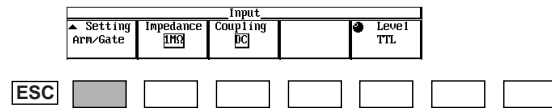

- Press the [Arm/Gate] soft key.

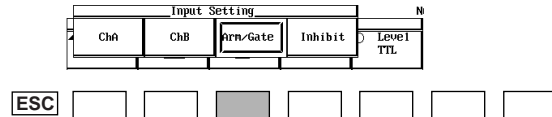

- Turn the rotary knob to select [TTL], [TTL/10], or [0V].

Explanation**Selecting the arming source**

Select from the following choices.

- Auto : Arming is activated automatically after the measurement is started.
- Ext : Arming is activated by an external arming input signal after the measurement is started.

When [Ext] is selected

Apply a signal to the terminal (this terminal is shared with the external gate) marked [EXT ARM/GATE IN] on the front panel.

- Input impedance : 1 M Ω (Typical value*)
- Input coupling : DC
- Arming level : Select TTL (1.4 V), TTL/10 (0.14 V), or 0 V
- Maximum input voltage : 40 V (DC+ACpeak)
- Minimum input pulse width : 30 ns
- Setup time : 50 ns (For the arming to become effective, the arming signal must arrive at least 50 ns earlier than the measurement signal.)

*Typical values represent typical or average values. They are not strictly guaranteed.

External arming (shared with external gate) input circuit

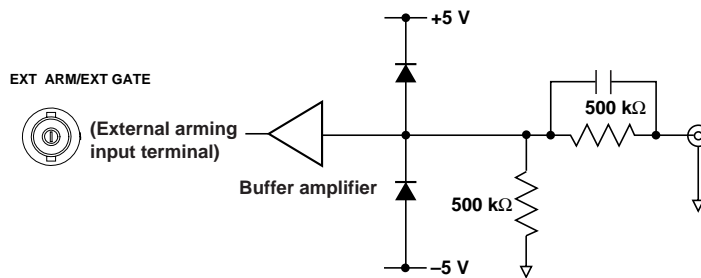
**CAUTION**

Applying a voltage exceeding the maximum input voltage to the external arming input terminals can damage the input section.

Selecting the slope

Select from the following choices. Select only during external arming.

- \uparrow : Arming occurs on the rising edge of the signal entering the external arming input terminal.
- \downarrow : Arming occurs on the falling edge of the signal entering the external arming input terminal.

6.4 Setting the Arming Source, Slope, and Delay

Selecting the type of arming delay

Select from the following choices. Select only during external arming.

- **OFF** : You cannot select the arming delay. Arming delay is not executed.
- **Time** : The measurement starts after being delaying for the specified time.
- **Event** : The measurement starts after being delaying for the specified number of events.

Setting the delay time

Set the time within the following range. Set only when using the time delay.

1.0 μ s to 1.0000000s (in 100 ns steps)

Setting the number of events

Set the number of events within the following range. Set only when using the event delay.

1 to 1000000

Note

The delay event corresponds to the number of events of the input signal of the channel being measured. However, in time interval measurements, it is the number of events of the input signal of CHA.

Selecting the arming level

Select from the following choices.

TTL (1.4 V), TTL/10 (0.14 V), and 0 V

6.5 Setting the Inhibit Function

≒For a functional description, see 1.5.≒

Procedure

1. Press the SAMPLE key to display the Sample menu.

Selecting the polarity

2. Press the [Inhibit] soft key to select the polarity.

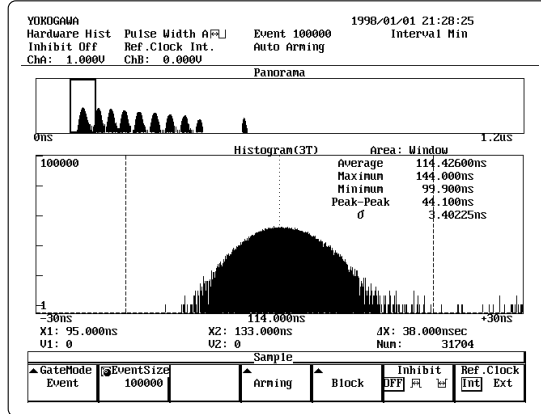

Selecting the inhibit level

3. Press the INPUT key to display the Input menu.
4. Press the [Setting] soft key to display the Input Setting menu.

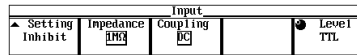

5. Press the [Inhibit] soft key.

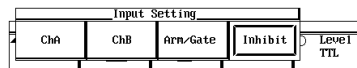



6. Turn the rotary knob to select [TTL], [TTL/10], or [0V].

Explanation

Selecting the polarity

Select from the following choices. The inhibit input is ineffective if it is turned [OFF].

-  : Inhibits measurement while a positive signal is being applied to the inhibit input terminal.
-  : Inhibits measurement while a negative signal is being applied to the inhibit input terminal.

Note

The inhibit signal is valid only within the maximum sampling time after arming activation. Signals outside this range are invalid.

When applying the inhibit signal

Apply a signal to the terminal marked [INHIBIT] on the front panel.

- Input impedance : 1 M Ω (Typical value*)
- Input coupling : DC
- Inhibit level : Select TTL (1.4 V), TTL/10 (0.14 V), or 0 V
- Maximum input voltage : 40 V (DC+AC peak)
- Minimum input pulse width : 30 ns
- Setup time : 50 ns (For the inhibit function to become effective, the inhibit signal must arrive at least 50 ns earlier than the measurement signal.)

* Typical values represent typical or average values. They are not strictly guaranteed.

Inhibit input circuit

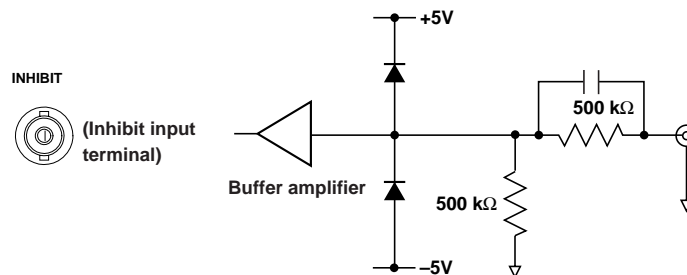

CAUTION

Applying a voltage exceeding the maximum input voltage to the inhibit input terminals can damage the input section.

Selecting the inhibit level

Select from the following choices.

TTL (1.4 V), TTL/10 (0.14 V), and 0 V

6.6 Setting the Input Coupling, Input Impedance, and Trigger

For a functional description, see 1.5.

Procedure

1. Press the INPUT key to display the Input menu.

Selecting the channel to set

2. Press the [Setting] soft key to display the Input Setting menu.

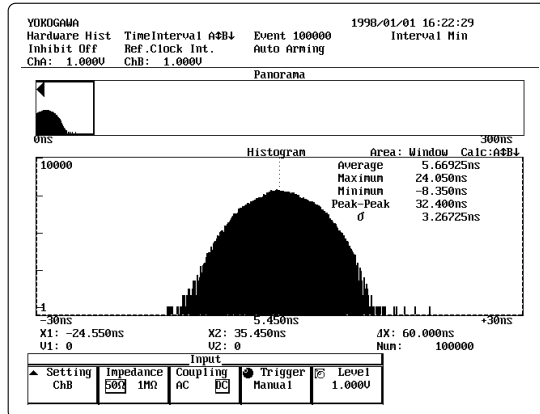

3. Press the [ChA] or [ChB] soft key.

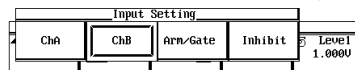

Selecting the input impedance

3. Press the [Impedance] soft key to select [50 Ω] or [1 MΩ].

Selecting the input coupling

4. Press the [Coupling] soft key to select [AC] or [DC].

Selecting the trigger mode

5. Press the [Trigger] soft key.
Turn the rotary knob to select [Manual], [SingleAuto], or [RepeatAuto].

Setting the trigger level

6. Press the [Level] soft key.
Use the rotary knob or the numerical keys to set the trigger level.

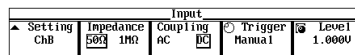

6.6 Setting the Input Coupling, Input Impedance, and Trigger

Explanation

Selecting the channel to set

The input conditions of CHA and CHB are selected individually. In addition, if you selected arming/gate or inhibit input, you can set the level.

Selecting the input impedance

Select either 50 Ω or 1 M Ω . If the input coupling is set to AC, the frequency characteristics vary depending on the input impedance. For details, see section 15.1.

Selecting the input coupling

Select either AC or DC. The frequency characteristics vary depending on the input coupling. For details, see section 15.1.

Selecting the trigger mode

Select from the following choices.

- **Manual** : Trigger using the specified trigger level (voltage).
- **SingleAuto** : Determines the trigger level from the value (%) specified on the first measurement after the measurement is started.
- **RepeatAuto** : Determines the trigger level from the value (%) specified for each measurement.

Setting the trigger level

Selectable range (when the trigger mode is Manual) : -5 V to +5 V (in 1 mV steps)

Selectable range (when the trigger mode is SingleAuto/RepeatAuto) : 0 to 100% (in 1% steps)

However, if you selected Arming/Gate or Inhibit for the channel, you will select from TTL (1.4 V), TTL/10 (0.14 V), and 0 V.

Note

The input impedance of EXT ARM/EXT GATE and INHIBIT is fixed to 1 M Ω .

6.7 Inputting/Outputting the Reference Signal

≒For a functional description, see 1.5≒

Procedure

Selecting the reference clock

1. Press the SAMPLE key to display the Sample menu.
2. Press the [Ref.Clock] soft key to select [Int] or [Ext].

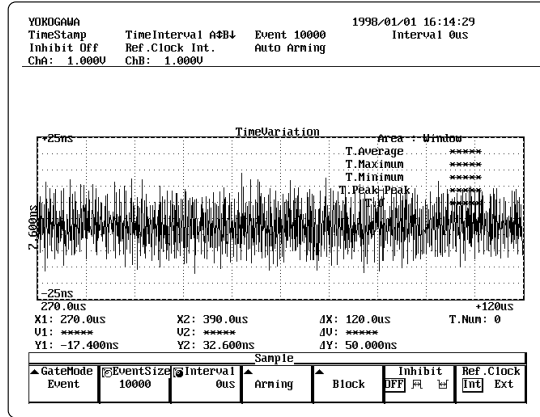

Explanation

Connecting a BNC cable

Connect a BNC cable to the reference input/output terminal on the rear panel of the instrument.

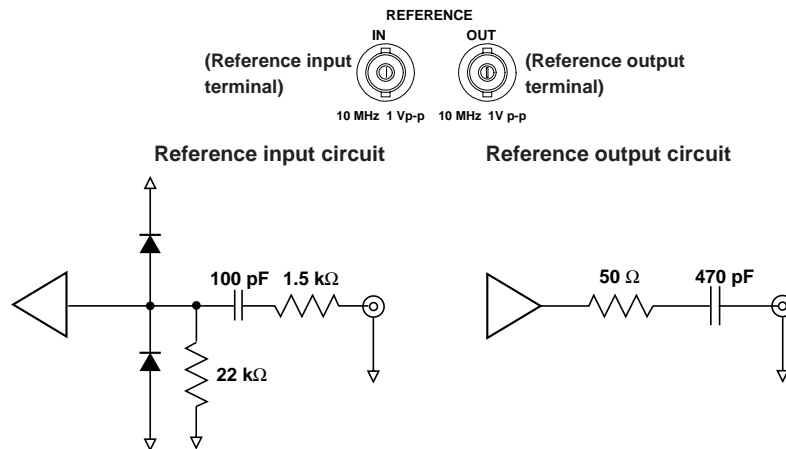

Inputting an external reference clock signal

Apply an external reference clock signal to the reference input terminal.

- Input frequency range : 10 MHz \pm 10 Hz
- Input impedance : 1 k Ω or more
- Input coupling : AC
- Input level : 1 Vp-p or more
- Maximum input voltage : \pm 10 V



CAUTION

Applying a voltage exceeding the maximum input voltage to the reference input terminal can damage the instrument.

Outputting the reference clock signal

Outputs the reference clock signal from the reference output terminal. The selected reference clock described in the earlier section “Selecting the reference” is constantly output from this terminal.

- Output frequency : 10 MHz(Typical value*)
- Output impedance : 50Ω(Typical value*)
- Output coupling : AC
- Output level : 1 Vp-p or greater, except this level applies to the case when the input impedance of the receiving side is 50 Ω .

* Typical values represent typical or average values. They are not strictly guaranteed.



CAUTION

Do not apply an external voltage to the reference output terminal. It can damage the instrument.

Selecting the reference

Select from the following choices.

- Int : Operate using the internal reference clock signal.
- Ext : Operate using the external reference clock signal.

7.1 Displaying the Histogram

≒For a functional description, see 1.7.≒

Procedure

1. Press the DISPLAY key to display the Display menu.

Displaying a histogram

2. Press the [Item] soft key to display the Display Item menu.

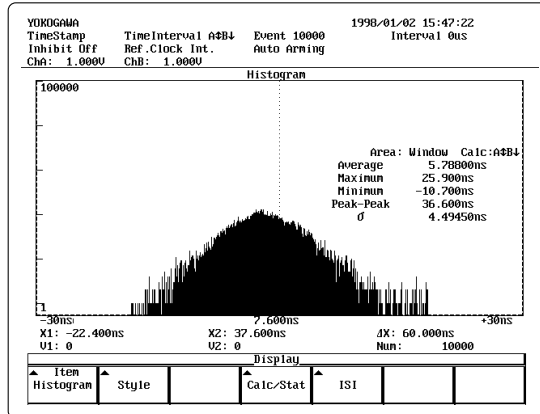

3. Press the [Histogram] soft key.

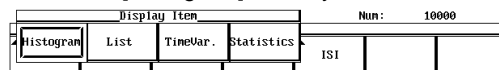

Set the display size of the histogram

4. Press the [Style] soft key to display the Display Style menu.

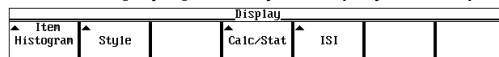

5. Press the [Graph Size] soft key to select [Half] or [Full].

Set the display format

5. Press the [Statistics], [Marker], or [Overlap] soft key to select [ON] or [OFF] for each.

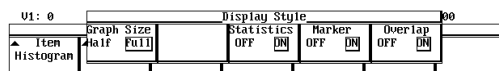

Explanation

Display size of the histogram (Graph Size)

Select from the following two choices.

Half: Displays the histogram on the left half of the screen. The right half displays the statistics.

Full: Displays the histogram on the entire screen.

Setting the display format (Style)

In addition to the histogram, you can select whether or not to display the following items.

- **Statistics**: Displays the statistics in the main window. The statistical parameters to be displayed are set in a dialog box that appears when the [Calc/Stat] soft key is pressed. For details, see section 7.6.
- **Marker**: Displays the read-out value of the X marker. The marker is set using a menu that is displayed when the MARKER key is pressed.
- **Overlap**
The ON/OFF setting becomes effective only for the following cases:
 - Time interval measurement with the slope set to $A \uparrow B \uparrow$ or $A \uparrow B \downarrow$.
 - Pulse width measurement with the polarity set to $\overleftrightarrow{\square}$.

ON: Superimposes the histogram of the slope/polarity that is selected with the Calculation Slope/Calculation Polarity item (displayed in orange) and the histogram of both slopes/polarities (displayed in blue).

OFF: Displays the histogram of the slope/polarity that is selected with the Calculation Slope/Calculation Polarity item (displayed in orange) and the histogram of both slopes/polarities (displayed in blue) in separate windows.

The following combinations of slopes and polarities can be selected.

- Time interval measurement: $A \uparrow B \uparrow$, $A \downarrow B \uparrow$, $A \uparrow B \downarrow$,
 $A \downarrow B \downarrow$, $A \uparrow B \downarrow$, $A \downarrow B \downarrow$
- Pulse width measurement: $\overleftrightarrow{\square}$, $\overleftarrow{\square}$, $\overrightarrow{\square}$

For the procedures related to setting the Calculation Slope/Calculation Polarity item in the Calculation/Statistics Setting menu, see section 7.6.

7.2 Displaying the List

≒For a functional description, see 1.7.≒

Procedure

1. Press the DISPLAY key to display the Display menu.

Displaying the list

2. Press the [Item] soft key to display the Display Item menu.

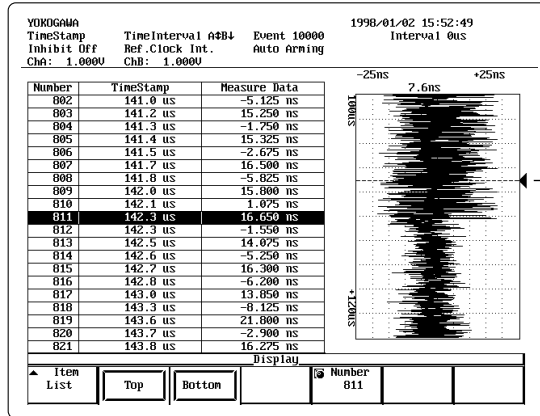

← Marks the position corresponding to the number that is highlighted in the list.



3. Press the [List] soft key.

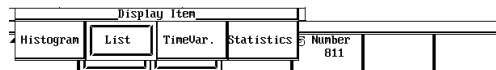

Setting the data to be displayed

4. Use the rotary knob or the numerical keys to set the number of the desired data. The specified data is highlighted and the position of the specified number is marked on the time variation display.

Displaying the top data

4. Press the [Top] soft key. The top data (first data) are highlighted.

Displaying the bottom data

4. Press the [Bottom] soft key. The bottom data (last data) are highlighted.



Specifying the block number (only for block sampling)

4. Press the [Block Num] soft key. Turn the rotary knob to set the block number that you wish to list.



Explanation

Displaying the list

Displays twenty data points at a time. Taking the first measurement data to be number one, the time stamps and measured data are displayed.

The list is displayed on the left side of the screen and the time variation is displayed vertically on the right side.

The dotted line and ◀ mark on the time variation screen indicate the data that are highlighted on the list.

Setting the data to list

You can set the data to be displayed.

The following methods are available to select the data.

- Specify the data number and display
- Display top data (top of the list) or bottom data (bottom of the list)

Specifying the block number

Block number is specified only when block sampling is used. The data of the specified block number are listed. The first data of each block become the top data of the list.

Note

If the ▲ or ▼ mark is displayed on the time variation screen, redo the scaling.

7.3 Displaying the Time Variation

≒For a functional description, see 1.7.≒

Procedure

1. Press the DISPLAY key to display the Display menu.

Displaying the time variation

2. Press the [Item] soft key to display the Display Item menu.

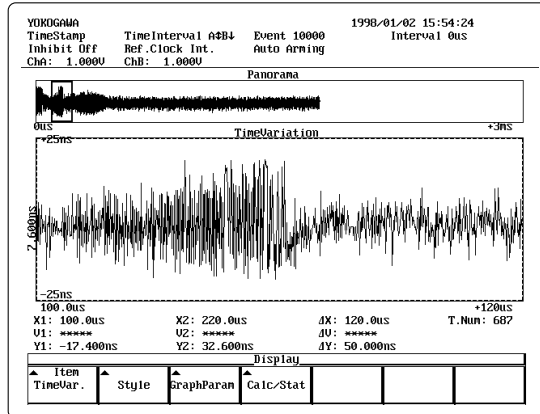

3. Press the [TimeVar.] soft key.

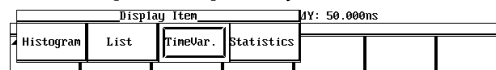

Set the display size of the time variation

4. Press the [Style] soft key to display the Display Style menu.
5. Press the [Graph Size] soft key to select [Half] or [Full].

Selecting the display format

5. Press the [Panorama], [Statistics], or [Marker] soft key to select [ON] or [OFF] for each.

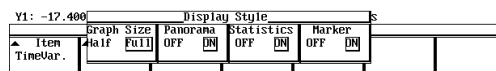

Setting the graticule

2. Press the [Graph Param] soft key to display the Graph Parameter menu. Press the [Grid], [Connect], or [Dot Type] soft key to set them appropriately.

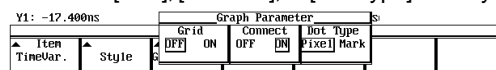

Specifying the block number (only for block sampling in which the statistical calculation area is set to [Block])

2. Press the [Block Num] soft key. Turn the rotary knob to set the number of the block for which you wish to display the statistics.

7.3 Displaying the Time Variation

Explanation

The size of the time variation display (Graph Size)

Select from the following two choices.

Half: Displays the time variation on the left half of the screen. The right half displays the statistics.

Full: Displays the time variation on the entire screen.

Selecting the display format (Style)

In addition to the time variation, you can display the following items.

- Panorama: Displays a panorama display. For setting the panorama display, see section 7.5.
- Statistics: Displays statistics. The statistical parameters to be displayed are set in a dialog box that appears when the [Calc/Stat] soft key is pressed. For details, see section 7.6.
- Marker: Displays the read-out values of the X and Y markers. The markers are set using a menu that is displayed when the MARKER key is pressed.

Setting the graph (Graph Parameter)

The following items can be set.

- Grid: Turn ON/OFF the grid.
- Connect: Set whether to linearly interpolate between data points.
- Dot Type: Set the dot to [Pixel] or [Mark].

Connect OFF



Connect ON



Dot Type:Pixel



Dot Type:Mark



Specifying the block number

The block number can only be specified during block sampling when the statistical calculation area is set to [Block]. The statistics of the specified block are displayed.

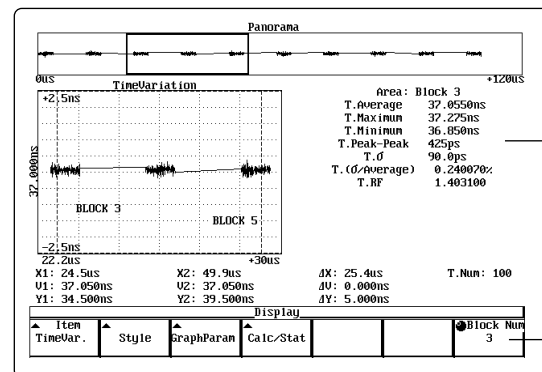

Displays the statistics of the specified block

Specify the block to display the statistics

7.4 Displaying the Statistics

≒For a functional description, see 1.7.≒

Procedure

1. Press the DISPLAY key to display the Display menu.

Displaying the statistics

2. Press the [Item] soft key to display the Display Item menu.

YOKOGAMA 1998-01/02 15:57:06
 TimeStamp TimeInterval A#B#4 Event 10000 Interval 0us
 Inhibit Off Ref.Clock Int. Auto Arming
 Chn: 1.000U Ch#: 1.000U

Item	Value
Average	5.70000ns
Maximum	25.500ns
Minimum	-10.700ns
Peak-Peak	36.600ns
σ	4.49450ns
σ /Average	*****
E.L. Error	*****
MELE	*****
Median	*****
Mode	*****
Number	10000

Statistics Value(Histogram) Area: Window Calc:A#B#4

Num: 10000

Display

▲ Item	Stat Item	▲	Calc/Stat			
Statistics	HIST	T.V.				

ESC

3. Press the [Statistics] soft key.

Display Item Num: 10000

Histogram	List	TimeVar.	Statistics			
-----------	------	----------	------------	--	--	--

ESC

Selecting the items for which to calculate the statistics

4. Press the [Stat Item] soft key to select [Hist] or [T.V.].

Display

▲ Item	Stat Item	▲	Calc/Stat			
Statistics	HIST	T.V.				

ESC

Setting the display format (only during block sampling when the statistical calculation area is set to [Block] and [T.V] was selected in step 4)

5. Press the [Style] soft key to select [All] or [Block].

• When [All] is selected

6. Press the [▲▼] soft key.
Turn the rotary knob to scroll through the block numbers.
7. Press the [◀▶] soft key.
Turn the rotary knob to scroll through the statistical parameters.

Display

▲ Item	Stat Item	Style	▲	Calc/Stat	▲▼	◀▶
Statistics	HIST	T.V.	All	Block		

ESC

• When [Block] is selected

6. Press the [Block Num] soft key.
Turn the rotary knob to specify the number of the block you wish to display.

Display

▲ Item	Stat Item	Style	▲	Calc/Stat	Block Num	
Statistics	HIST	T.V.	All	Block	1	

ESC

Explanation

Selecting the items for which to calculate the statistics (Stat Item)

Select from the following choices.

- Hist : Set the range over which to calculate the statistics with the measured values and frequencies.
- T.V. : Set the range over which to calculate the statistics with the time stamps and measured values.

Setting the display format (Style)

For data that were block sampled, if the statistical calculation area is [Block] and the item for which to calculate the statistics is set to time variation (T.V.), then the display format of the statistics can be selected from the following choices.

- All : Lists the statistics of all blocks. Up to four statistical parameters and up to 20 blocks can be displayed at once. Rotary knobs can be used on the [▲▼] and [◀▶] keys to scroll through the blocks and statistical parameters.
- Block : Displays the statistics for each block. All statistical parameters can be displayed at once.

Statistical parameters that are calculated

The following statistical parameters are calculated.

The items inside parentheses are displayed when [T.V.] is selected.

- Average (T.Average)
- Maximum (T.Maximum)
- Minimum (T.Minimum)
- Peak-Peak (T.Peak-Peak)
- σ (T. σ)
- σ /Average (T.(σ /Average))
- σ /T (None)
- E.L.Error (None)
- MELE (None)
- Median (None)
- Mode (None)
- – (T.(P-P/Average))
- – (T.RF)
- Number (T.Num)

Asterisks (*) are displayed for the statistics of the parameters that are not turned ON in the dialog box that appears by pressing the [Calc/Stat] soft key (see section 7.5)

When the statistic item is [T.V.].

Item	Value
T.Average	6.1600ns
T.Maximum	25.875ns
T.Minimum	-10.700ns
T.Peak-Peak	36.575ns
T. σ	7.390ns
T.(σ /Average)	*****
T.RF	*****

When the statistic item is [Hist].

Item	Value
Average	49.6300ns
Maximum	49.950ns
Minimum	48.900ns
Peak-Peak	1.050ns
σ	120.00ps
σ /Average	0.241753%
σ /T	0.299974%
E.L.Error	200.00ps
MELE	0.520275%
Median	49.650ns
Mode	49.625ns
Number	10000

When the statistic item and format are [T.V.] and [Block], respectively. [All], respectively.

Item	Value
T.Average	37.6575ns
T.Maximum	37.350ns
T.Minimum	36.825ns
T.Peak-Peak	525ps
T. σ	100.00ps
T.(σ /Average)	0.270242%
T.(P-P/Average)	1.416669%
T.RF	1.403100%
T.Num	100

Block	T.Average	T.Maximum	T.Minimum	T.Peak-Peak
1	---	---	---	---
2	49.4575ns	49.800ns	48.900ns	900ps
3	49.6900ns	49.900ns	49.275ns	625ps
4	49.6700ns	49.925ns	49.375ns	550ps
5	49.6900ns	49.925ns	49.475ns	450ps
6	49.6650ns	49.900ns	49.350ns	550ps
7	49.5725ns	49.875ns	49.275ns	600ps
8	49.7400ns	49.950ns	49.500ns	450ps
9	49.5675ns	49.800ns	49.350ns	450ps
10	49.6650ns	49.925ns	49.400ns	525ps

Note

[-----] is displayed when the measured data are invalid, or measured the data do not exist.

7.5 Displaying the Panorama Display

≡For a functional description, see 1.7.≡

Procedure

1. Press the DISPLAY key to display the Display menu.
2. Press the [Item] soft key to display the Display Item menu.

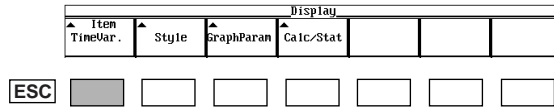

3. Press the [TimeVar.] soft key.

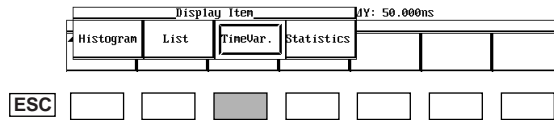

Displaying the panorama

4. Press the [Style] soft key to display the Display Style menu and press the [Panorama] soft key to select [ON].

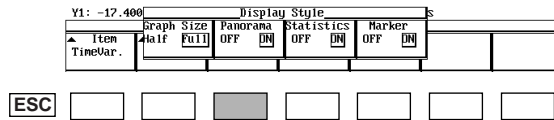

Setting the range to display in the panorama display

5. Press the SCALE key to display the Scale menu.
6. Press the [Panorama] soft key to display the Panorama menu.

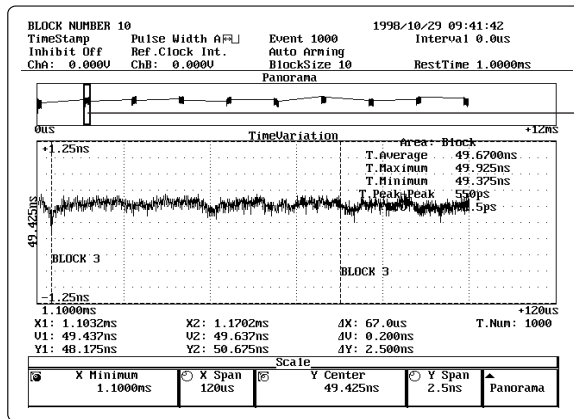

7.5 Displaying the Panorama Display

- Press the [Area] soft key.
Turn the rotary knob to set the range to display in the panorama display.

Setting the range to zoom display

- Press the [ZoomSpan] soft key.
Turn the rotary knob to set the range of the zoom display (size of the zoom box).

Moving the zoom position

- Press the [Position] soft key.
Turn the rotary knob to move the position of the zoom box.

Setting the speed of movement for the zoom box

- Pressing the [Movement] soft key and selecting ► decreases the speed of movement of the zoom box. Selecting ►► increases the speed of movement.

Moving the zoom box to the left end

- Pressing the [Adjust] soft key moves the zoom box to the left end of the panorama window.

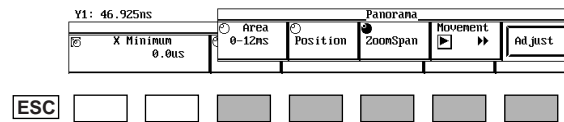

Explanation

Panorama display

The data can be displayed in the panorama window at the top section of the time variation display.

In the panorama display, a maximum of 6000 s of time variation can be listed and the waveform in the zoom box can be displayed zoomed in the main window. The panorama function is used when you wish to look at the entire set of acquired data.

Setting the panorama display area

You can set the range of the panorama display. The following ranges are available. 0-60/120/300/600 μ s, 1.2/3/6/12/30/60/120/300/600 ms, 1.2/3/6/12/30/60/120/300/600/1200/3000/6000 s

Setting the range of the zoom display

You can set the range of the zoom display (size of the zoom box). The following ranges are available.

6/12/30/60/120/300/600 μ s, 1.2/3/6/12/30/60/120/300/600 ms, 1.2/3/6/12/30/60/120/300/600/1200/3000/6000 s

Moving the zoom position

You can set which section (zoom position) of the data in the panorama display on which to zoom.

Adjustment function

This function is used to move the zoom box to the left end of the panorama window, which is useful such as when the zoom box is outside of the panorama window.

When the zoom box is outside the panorama window, the following marker is displayed in the panorama window.

- ▶ : A section of the zoom box extends beyond the right end of the panorama display
- ▶▶ : The zoom box is beyond the right end of the panorama display.

Selecting the speed of movement

- ▶ : Moves one dot at a time in the window.
- ▶▶ : Moves five dots at a time in the window.

Note

Changing the size or position of the zoom window also changes the [X Span] and [X Minimum] values of the SCALE key.

7.6 Setting the Statistical Calculation Parameters (Calc/Stat)

≒For a functional description, see 1.6.≒

Procedure

1. Press the DISPLAY key to display the Display menu.
2. Press the [Calc/Stat] soft key to display the Calculation / Statistics Setting menu.

For histogram display

Setting the statistical calculation area

3. Turn the rotary knob to select the [Calculation Area] item.
4. Press the SELECT key to select [Window] or [Marker].

Setting the constant T

5. Turn the rotary knob to select the [T Value] item.
6. Press the SELECT key to display the numerical input box and enter the value using the numerical keys.

Selecting the statistical parameters to calculate

7. Use the rotary knob to select the buttons under [Statistics] and press the SELECT key to check them.

Selecting [All Clear] and pressing the SELECT key removes all the checks.

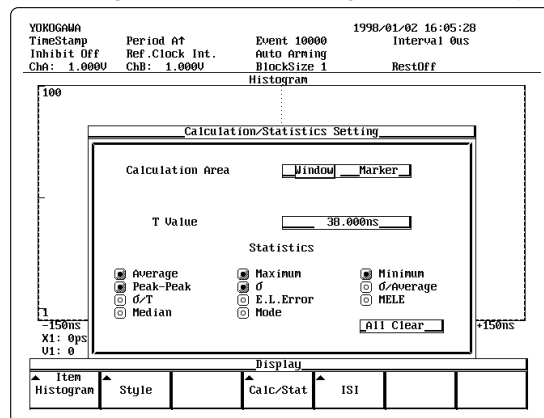

Selecting the calculation polarity (only for A ↓ B ↑, A ↑ B ↓ and $\overleftrightarrow{A \leftrightarrow B}$)

8. Turn the rotary knob to select the [Calculation Slope]/[Calculation Polarity] item.
9. Press the SELECT key to select one.

For time variation display**Setting the statistical calculation area**

- Turn the rotary knob to select the [Calculation Area] item.
- Press the SELECT key to select [Window], [Marker], or [Block].

Selecting the statistical parameters to calculate

- Use the rotary knob to select the buttons under [Statistics] and press the SELECT key to check them.

Selecting [All Clear] and pressing the SELECT key removes all the checks.

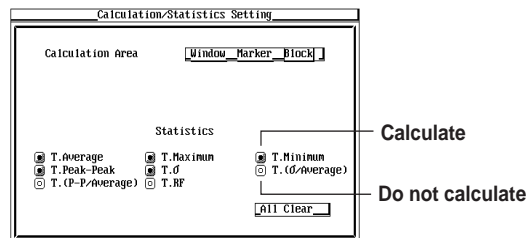
**Explanation****Setting the statistical calculation area**

You can set the area over which to calculate statistics.

- Window** : The entire displayed window.
- Marker** : The area enclosed by the X1, X2, Y1, and Y2 markers.
- Block** : When block sampling, the specified block (selectable only during time variation display).

When block sampling is OFF, the entire data set is used to calculate the statistics.

Statistical parameters to be calculated

Select from the following choices. The calculated parameters and the area for calculation are different for the histogram and time variation displays.

Histogram display

- Average
- Maximum
- Minimum
- Peak-Peak
- σ
- σ /Average
- σ /T
- E.L.Error
- MELE
- Median
- Mode

Time variation display

- T.Average
- T.Maximum
- T.Minimum
- T.Peak-Peak
- T. σ
- T.(σ /Average)
- T.(P-P/Average)
- T.RF

Constant T (T Value)

Set this value only for histogram displays.

Selectable range : 1 ns to 250 ns (in 25 ps steps)

7.6 Setting the Statistical Calculation Parameters (Calc/Stat)

Selecting the calculation polarity (Calculation Slope/Calculation Polarity)

Statistics can be calculated on data having the specified slope or polarity. The histogram corresponding to the specified slope or polarity is displayed in orange; the histogram of both slopes or polarities is displayed in blue.

You can select the slope or polarity only for the following cases:

When the measurement function is set to time interval and the slope is set to

A ↓ B ↑ or A ↑ B ↓

- **A ↑ B ↑** : Calculates the statistics on the data from the rising edge of A to the rising edge of B.
- **A ↓ B ↑** : Calculates the statistics on the data from the falling edge of A to the rising edge of B.
- **A ↑ B ↓** : Calculates the statistics on the data from rising or falling edge of A to the rising edge of B.
- **A ↑ B ↓** : Calculates the statistics on the data from rising edge of A to the falling edge of B.
- **A ↓ B ↓** : Calculates the statistics on the data from falling edge of A to the falling edge of B.
- **A ↑ B ↓** : Calculates the statistics on the data from rising or falling edge of A to the falling edge of B.

When the measurement function is set to pulse width and the polarity is set to



- : Calculates the statistics only on the positive side of the waveform.
- : Calculates the statistics only on the negative side of the waveform.
- : Calculates the statistics on both the positive and negative sides of the waveform.

Time interval measurement

Calculation/Statistics Setting	
Calculation Area	<input type="text" value="Window"/> <input type="text" value="Marker"/>
Calculation Slope	<input type="text" value="A↑B↓"/> <input type="text" value="A↓B↑"/>
T Value	<input type="text" value="40.000ns"/>

Statistics

Pulse width measurement

Calculation/Statistics Setting	
Calculation Area	<input type="text" value="Window"/> <input type="text" value="Marker"/>
Calculation Polarity	<input type="text" value="P"/> <input type="text" value="N"/>
T Value	<input type="text" value="40.000ns"/>

7.7 Changing the Scale Value

≡For a functional description, see 1.7.≡

Procedure

Executing auto scaling

1. Pressing the AUTO SCALE key executes auto scaling.

Executing manual scaling

1. Press the SCALE key to display the Scale menu.

For histogram display

- Setting the center value of the X-axis
2. Press the [X Center] soft key.
Use the rotary knob or the numerical keys to set the value.
 - Selecting the X-axis span
 3. Press the [X Span] soft key.
Turn the rotary knob to select the value.
 - Selecting the maximum value of the Y-axis
 4. Press the [Y High] soft key.
Turn the rotary knob to select the value.
 - Selecting the scale type of Y-axis
 5. Press the [Y Axis] soft key to select [Lin] or [Log].

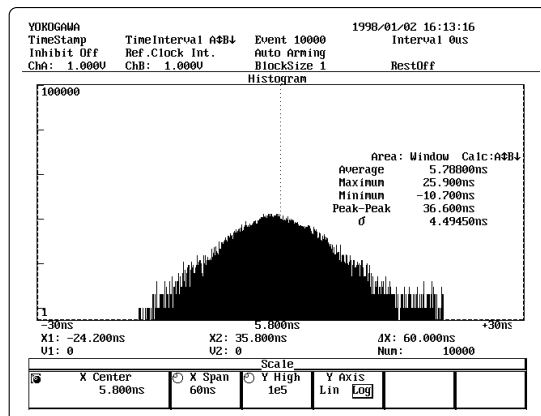

ESC [] [] [] [] [] [] []

For time variation display

- Setting the minimum value of the X-axis
2. Press the [X Minimum] soft key.
Use the rotary knob or the numerical keys to set the value.
 - Selecting the X-axis span
 3. Press the [X Span] soft key.
Turn the rotary knob to select the value.
 - Setting the center value of the Y-axis
 4. Press the [Y Center] soft key.
Use the rotary knob or the numerical keys to set the value.

7.7 Changing the Scale Value

- Selecting the Y-axis span
5. Press the [Y Span] soft key.
Turn the rotary knob to select the value.

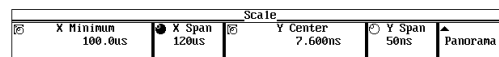
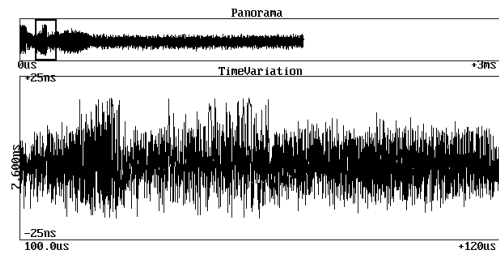

Explanation

The instrument provides both auto scaling and manual scaling functions.

Auto scaling

Sets the X- and Y-axes automatically according to the measured data.

Manual scaling

You can also manually set the X- and Y-axes. The setting parameters are different for the histogram display and time variation display as follows:

For histogram display

Range of center values of the X-axis	: -50.000 ns to 20.000000000 ms (in 25 ps steps)
Selections for the X-axis span	: Select from 1.5/3/7.5/15/30/60/150/300/600 ns, 1.5/3/6/15/30/60/150/300/600 μ s, 1.5/3/6/15/30 ms
Selections for the maximum value of the Y-axis	: 10/20/40/100/200/400/1000/2000/4000/10000/20000/40000/100000/200000/400000/1e6/1e7/1e8/1e9(Lin) 1e1/1e2/1e3/1e4/1e5/1e6/1e7/1e8/1e9(Log)
Selections for the scale type of the Y-axis	: Select Lin (linear scale) or Log(logarithmic scale)

For time variation display

Range of minimum values of the X-axis	: 0 to 3200.0000000 s(in 100 ns steps)
Selections for the X-axis span	: Select from 6/12/30/60/120/300/600 μ s, 1.2/3/6/12/30/60/120/300/600 ms, 1.2/3/6/12/30/60/120/300/600/1200/3000/6000 s
Range of center values of the Y-axis	: -50 ns to 20 ms(in 25 ps steps)
Selections for the Y-axis span	: Select from 500 ps, 1/2.5/5/10/20/50/100/200/500 ns, 1/2/5/10/20/50/100/200/500 μ s, 1/2/5/10/20 ms

7.8 Reading the Data

≒For a functional description, see 1.6.≒

Procedure

Turning ON/OFF the marker

1. Press the MARKER key to display the Marker menu.
2. Press the [Marker] soft key to select [ON] or [OFF].

For histogram display

Moving the X marker

3. Press the [X Marker] soft key to select [X1] or [X2].
Turn the rotary knob to move the marker.
The measured value and frequency at the position of the marker are displayed in the bottom section of the main window.

Moving the X1 and X2 markers simultaneously

4. Press the [X1&X2] soft key.
Turning the rotary knob causes the X1 and X2 markers to move together.

Setting the statistical calculation area (when the calculation area is set to Marker)

5. Press the [Y Marker] soft key.
Use the rotary knob or the numerical keys to set the value

Selecting the speed of movement of the marker

6. Pressing the [Movement] soft key and selecting ► decreases the speed of movement of the zoom box. Selecting ►► increases the speed of movement.

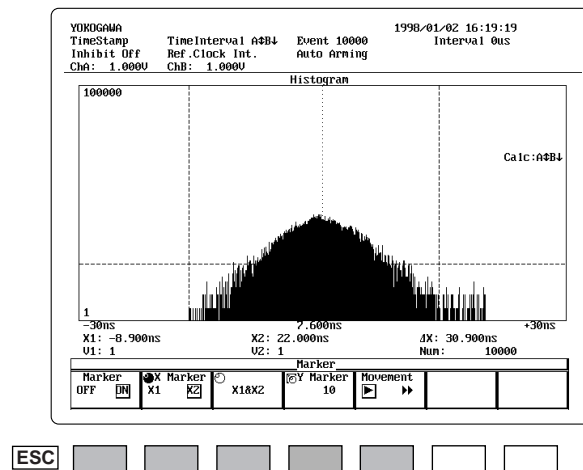

For time variation display

Moving the X marker

3. Press the [X Marker] soft key to select [X1] or [X2].
Turn the rotary knob to move the marker
The time stamp and measured value at the position of the marker are displayed in the bottom section of the main window.

Moving the X1 and X2 markers simultaneously

4. Press the [X1&X2] soft key.
Turning the rotary knob causes the X1 and X2 markers to move together.

Moving the Y marker

5. Press the [Y Marker] to select [Y1] or [Y2].
Turn the rotary knob to move the marker.
The measured value at the marker is displayed.

Moving the Y1 and Y2 markers simultaneously

6. Press the [Y1&Y2] soft key.
Turning the rotary knob causes the Y1 and Y2 markers to move together.

Selecting the speed of movement of the marker

7. Pressing the [Movement] soft key and selecting ► decreases the speed of movement of the zoom box. Selecting ►► increases the speed of movement.

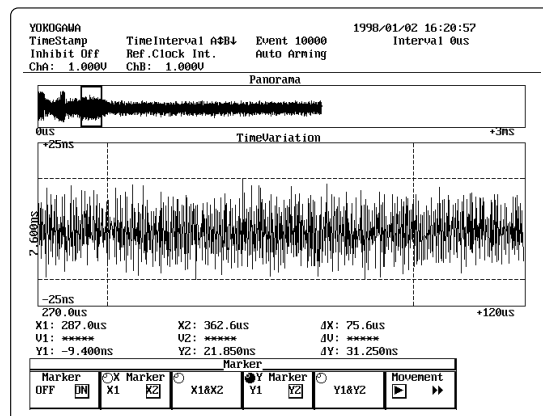

Explanation

Turn ON/OFF the marker

You can read out the data in the histogram or time variation display using the marker. The read-out value is displayed in the bottom section of the main window. You can also use Display key's [Style] to turn ON/OFF the marker and read-out values.

Marker types

The marker type is different for the histogram and time variation displays.

During histogram display

X Marker(X1, X2) : Displays the value of the x coordinate (measured value) and the frequency of the X1 and X2 markers.

Y Marker : This marker is used to set the statistical calculation area. This marker becomes effective when the calculation area is set to Marker.

During time variation display

X Marker(X1, X2) : Displays the value of the x coordinate (time stamp) and the measured value of the X1 and X2 markers.

Y Marker(Y1, Y2) : Displays the value of the y coordinate (measured value).

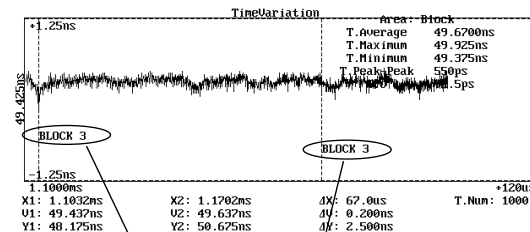

Displays which block the X marker is reading the value when block sampling.

Range of movement of the X1 marker

You can move the marker to the same position as or to the left of the X2 marker.

Range of movement of the X2 marker

You can move the marker to the same position as or to the right of the X1 marker.

Selecting the speed of movement of the marker

- ▶ : Moves one dot at a time in the window.
- ▶▶ : Moves five dots at a time in the window.

Y marker range (during histogram display)

0 to 512, 000

Range of movement of the Y1 marker (during time variation display)

You can move the marker to the same position as or below the Y2 marker.

Range of movement of the Y2 marker (during time variation display)

You can move the marker to the same position as or above the Y1 marker.

Note

- If there are multiple data points at the marker position, the average of those values is displayed.
- If there is no data at the marker position, an asterisk (*) is displayed.
- In the histogram display, if the value of the Y marker is larger than the maximum value of the Y-axis (Y High), the Y marker is not displayed.

8.1 Displaying the Histogram

≡For a functional description, see 1.7.≡

Procedure

1. Press the DISPLAY key to display the Display menu.

Displaying the histogram

2. Press the [Item] soft key to display the Display Item menu.

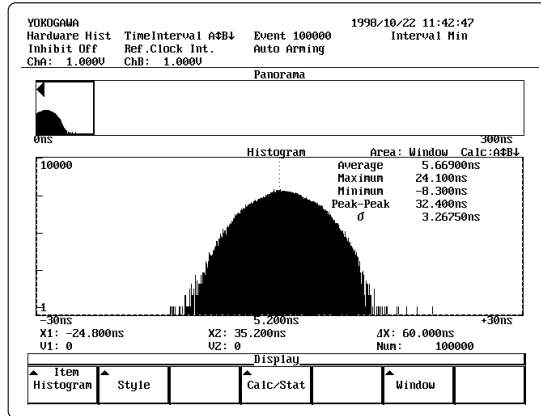

3. Press the [Histogram] soft key.

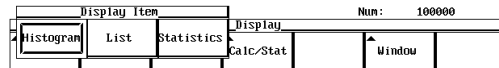

Setting the display size of the histogram

4. Press the [Style] soft key to display the Display Style menu.

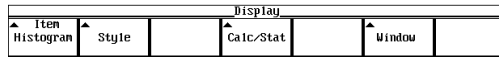

5. Press the [Graph Size] soft key to display [Half] or [Full].

Setting the display format

5. Press the [Panorama], [Statistics], [Marker], or [Overlap] soft key to select [ON] or [OFF] for each item.

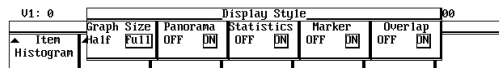

Selecting the window to display (only during multi-window or auto window)

7. Press the [WindowNum] soft key.
Turn the rotary knob to select the window.

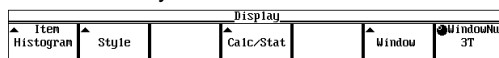

8 Displaying the Measured/Calculated Results in the Hardware Histogram Mode

Explanation

Display size of the histogram (Graph Size)

Select from the following two choices.

Half : Displays the histogram on the left side of the screen. The right side displays the statistics.

Full : Displays the histogram on the entire screen.

Setting the display format (Style)

In addition to the histogram, you can select whether or not to display the following items.

- Panorama : Displays a panorama display. For setting the panorama display, see section 8.4.
- Statistics : Displays statistics in the main window. The statistical parameters to be displayed are set in a dialog box that appears when the [Calc/Stat] soft key is pressed. For details, see section 8.7.
- Marker : Displays the read-out values of the X marker. The marker is set using the menu that is displayed when the MARKER key is pressed.

- Overlap

The ON/OFF setting becomes effective only for the following cases:

- Time interval measurement with the slope set to $A \uparrow B \downarrow$ or $A \downarrow B \uparrow$.
- Pulse width measurement with the polarity set to $\overleftrightarrow{\square}$.

ON : Overlaps the histogram of the slope/polarity that is selected with the Calculation Slope/Calculation Polarity item (displayed in orange) and the histogram of both slopes/polarities (displayed in blue).

OFF : Displays the histogram of the slope/polarity that is selected with the Calculation Slope/Calculation Polarity item (displayed in orange) and the histogram of both slopes/polarities (displayed in blue) in separate windows.

The following combinations of slopes and polarities can be selected.

- Time interval measurement : $A \uparrow B \uparrow$, $A \downarrow B \uparrow$, $A \uparrow B \downarrow$
 $A \downarrow B \downarrow$, $A \uparrow B \downarrow$, $A \downarrow B \downarrow$
- Pulse width measurement : $\overleftrightarrow{\square}$, $\overleftarrow{\square}$, $\overrightarrow{\square}$

For the procedures related to setting the Calculation Slope/Calculation Polarity item in the Calculation/Statistics Setting menu, see section 8.7.

Selecting the window to display

You can select the window only when using the multi-window or auto window function.

Displays the histogram of the selected window. The following windows can be selected.

- Window specified in the Window Parameter Setting menu. (3T, 4T, etc.)
- All (All windows)
- Summation

8.2 Displaying the List

≒For a functional description, see 1.7.≒

Procedure

1. Press the DISPLAY key to display the Display menu.

Displaying the list

2. Press the [Item] soft key to display the Display Item menu.

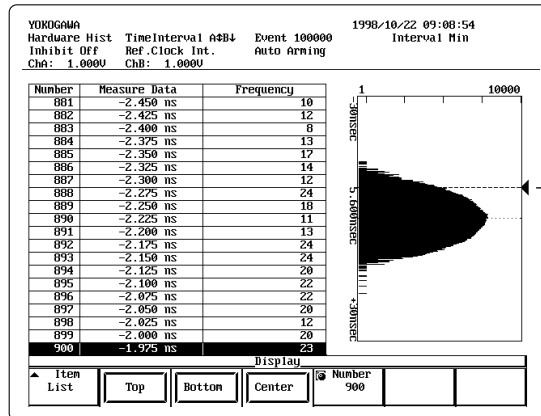

← Marks the position corresponding to the number that is highlighted in the list

ESC

3. Press the [List] soft key.

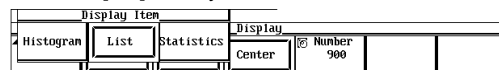

ESC

Setting the data to be displayed

4. Use the rotary knob or the numerical keys to set the number of the desired data. The specified data is highlighted and the position of the specified number is marked on the time variation display.

Displaying the top data

4. Press the [Top] soft key. The top data (first data) are highlighted.

Displaying the bottom data

4. Press the [Bottom] soft key. The bottom data (last data) are highlighted.

Displaying the center data

4. Press the [Center] soft key. The center data are highlighted.

Selecting the window to display (only during multi-window)

4. Press the [WindowNum] soft key. Turn the rotary knob to select the window for which you wish to display the list.

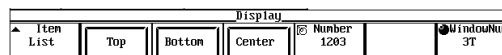

ESC

Explanation

Displaying the list

Displays twenty data points at a time. Taking the left most data in the window to be number one, the measured values and frequencies are displayed.

The list is displayed on the left side of the screen and the histogram is displayed vertically on the right side.

The dotted line and ◀ mark on the histogram display indicate the data that are highlighted on the list.

Setting the data to list

You can set the data to be displayed.

The following methods are available to select the data.

- Specify the data number and display
- Display the top data (top of the list), the bottom data (bottom of the list), or the center data (center of the list)

Selecting the window to display

You can select the window only when using the multi-window or auto window function.

Displays the list and histogram of the selected window. The following windows can be selected.

- Window specified in the Window Parameter Setting menu. (3T, 4T, etc.)
- All (All windows)
- Summation (Displays only the histogram)

Note

When displaying the list, the [Window] soft key of the DISPLAY key is not displayed even when using the multi-window or auto window function. To display the [Window] soft key, change to the histogram display.

8.3 Displaying the Statistics

≡For a functional description, see 1.7.≡

Procedure

1. Press the DISPLAY key to display the Display menu.

Displaying the statistics

2. Press the [Item] soft key to display the Display Item menu.

1998/12/07 13:44:18 !

Hardware Hist Pulse Width APL Event 100000 Interval Min
 Inhibit Off Ref.Clock Int. Auto Arming
 Chn: 1.000V Chd: 1.000V

Window	Average	Value(Histogram)	d	Area	Marker	σ/Average	σ/T
3T	114.56825ms	3.41350ms		2.379394z		9.225509z	
4T	152.55375ms	3.04775ms		1.997900z		8.237498z	
5T	183.39475ms	3.26600ms		1.781910z		8.832242z	
6T	216.67300ms	3.65125ms		1.685156z		9.868321z	
7T	253.0450ms	3.8660ms		1.525574z		10.433467z	
8T	291.9750ms	3.7775ms		1.293754z		10.209312z	
9T	329.1050ms	3.7700ms		1.14543z		10.188358z	
10T	359.6925ms	3.8280ms		1.044390z		10.32178z	
11T	402.6275ms	3.6350ms		0.982556z		9.821444z	
14T	512.5175ms	2.4625ms		0.488232z		6.652091z	

Display

▲ Item	Statistics	Style	[All] Window	▲ Calc/Stat	◀ ▶
--------	------------	-------	--------------	-------------	-----

ESC

3. Press the [Statistics] soft key.

Display Item

▲ Histogram	List	Statistics	▲ Calc/Stat	◀ ▶
-------------	------	------------	-------------	-----

ESC

Setting the display format (only when using the multi-window or auto window function)

4. Press the [Style] soft key to select [All] or [Window].

- When [All] is selected

5. Turn the rotary knob to change the statistical parameters to be displayed.

Display

▲ Item	Statistics	Style	[All] Window	▲ Calc/Stat	◀ ▶
--------	------------	-------	--------------	-------------	-----

ESC

- When [Window] is selected

5. Turn the rotary knob to select the number of the window for which to calculate the statistics (WindowNum).

Display

▲ Item	Statistics	Style	[All] Window	▲ Calc/Stat	WindowNum	3T
--------	------------	-------	--------------	-------------	-----------	----

ESC

Explanation

Setting the display format (Style)

When using the multi-window or auto window function, you can select the display format of the statistical calculations from the following choices.

- All : Lists the statistics of all windows. Only four statistical parameters can be displayed at once, but you can scroll through the parameters using the rotary knob.
Displays only the parameters that are checked in the dialog box that appears when the [Calc/Stat] soft key is pressed.
- Window: Displays the statistics for each window. All statistical parameters are displayed at once. You can select the following windows.
 - Window specified in the Window Parameter Setting menu (3T, 4T, etc.)
 - Summation (The sum of all windows. The statistics that are displayed are Peak-Peak, σ , and σ/T)
 - All (Displays [----]for all parameters)

When the format is All

Window	Statistics Value(Histogram)		Area: Marker	
	Average	Peak-Peak	σ	Number
3T	114.5925ns	29.600ns	3.9025ns	3212
4T	151.5175ns	25.700ns	3.3625ns	2395
5T	182.8175ns	35.100ns	3.6725ns	1656
6T	216.3425ns	35.900ns	4.1175ns	1195
7T	253.1850ns	23.400ns	4.0000ns	728
8T	292.2775ns	22.500ns	4.0200ns	398
9T	329.0150ns	20.700ns	4.0275ns	212
10T	365.1150ns	21.300ns	3.9500ns	145
11T	401.025ns	17.200ns	4.325ns	23
14T	512.250ns	11.100ns	2.625ns	26
Sun	*****	35.900ns	5.46550ns	10000

When the format is Window

Statistics	Value(Histogram)	Area: Marker
Item		Value
Average	114.42500nsec	
Maximum	144.0000nsec	
Minimum	99.9000nsec	
Peak-Peak	44.100nsec	
σ	3.40225nsec	
σ/T	*****	
σ /Average	*****	
E.L.Error	*****	
MELE	*****	
Median	*****	
Mode	*****	
Number	31703	

Statistical parameters that are calculated

The following statistical parameters are calculated.

Asterisks (*) are displayed for the statistics of the parameters that are not turned ON in the dialog box that appears by pressing the [Calc/Stat] soft key (see section 8.7).

- Average
- Maximum
- Minimum
- Peak-Peak
- σ
- σ/T
- σ /Average
- E.L.Error
- MELE
- Median
- Mode
- Measured T or Estimated T (only during auto window)
- Number (The number of samples of the items of which the statistics are calculated)

Note

- [----] is displayed when the measured data are invalid, or the measured data do not exist.
- When displaying the statistics, the [Window] soft key of the DISPLAY key is not displayed even when using the multi-window or auto window function. To display the [Window] soft key, change to the histogram display.

8.4 Displaying the Panorama Display

≡For a functional description, see 1.7.≡

Procedure

1. Press the DISPLAY key to display the Display menu.
2. Press the [Item] soft key to display the Display Item menu.

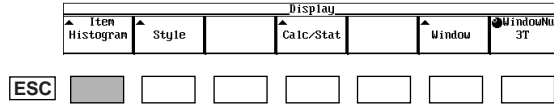

3. Press the [Histogram] soft key.

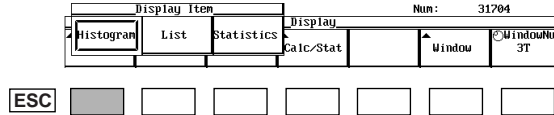

Displaying the panorama

4. Press the [Style] soft key to display the Display Style menu and press the [Panorama] soft key to select [ON].

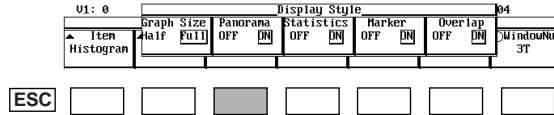

Setting the range to display in the panorama display

5. Press the SCALE key to display the Scale menu.
6. Press the [Panorama] soft key to display the Panorama menu.

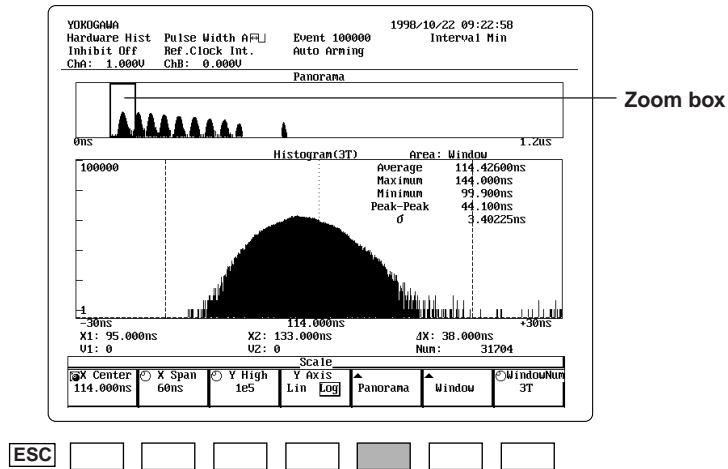

8.4 Displaying the Panorama Display

7. Press the [Area Min] soft key.
Turn the rotary knob to set the value at the left end of the panorama display.
8. Press the [Area Max] soft key
Turn the rotary knob to set the value at the right end of the panorama display.

Setting the range to display zoomed

9. Press the [ZoomSpan] soft key
Turn the rotary knob to set the range of the zoom display (size of the zoom box).

Moving the zoom position

10. Press the [Position] soft key
Turn the rotary knob to move the zoom box position.

Setting the speed of movement of the zoom box

11. Pressing the [Movement] soft key and selecting ► decreases the speed of movement of the zoom box. Selecting ►► increases the speed of movement.

Moving the zoom position to the center

12. Pressing the [Adjust] soft key moves the zoom box to the center of the panorama window.

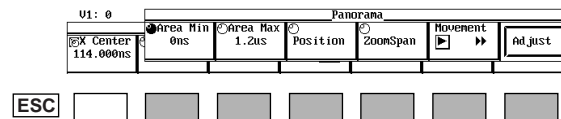

Explanation

Panorama display

The data can be displayed in the panorama window at the top section of the histogram display.

In the panorama display, a maximum of 3.6 μ s of histogram can be listed and the waveform in the zoom box can be displayed zoomed in the main window. The panorama function is used when there are multiple histograms and you wish to look at the entire data.

Setting the display area of the panorama display (Area Min/Area Max)

You can set the range of the panorama display. The following ranges are available.

Area Min : 0/300/600/900 ns, 1.2/1.5/1.8/2.1/2.4/2.7/3/3.3 μ s

Area Max : 300/600/900 ns, 1.2/1.5/1.8/2.1/2.4/2.7/3/3.3/3.6 μ s

Setting the range of the zoom display

You can set the range to zoom display (size of the zoom box). The following ranges are available.

1.5/3/7.5/15/30/60/150/300/600 ns, 1.5/3/6 μ s

Moving the zoom position

You can set which section (zoom position) of the data in the panorama display for which to display zoomed.

Adjustment function

This function is used to move the zoom box to the center of the panorama window such as when the zoom box is outside the panorama window.

When the zoom box is outside the panorama window, the following marker is displayed in the panorama window.

- ▶ : A section of the zoom box extends beyond the right end of the panorama display.
- ▶▶ : The zoom box is beyond the right end of the panorama display.
- ◀ : A section of the zoom box extends beyond the left end of the panorama display.
- ◀◀ : The zoom box is beyond the left end of the panorama display.

Note

Changing the size or position of the zoom window also changes the [X Center] and [X Span] values of the SCALE key.

8.5 Using the Multi-Window Function

≡For a functional description, see 1.7.≡

Procedure

1. Press the DISPLAY key to display the Display menu.
Press the [Window] soft key to display the Window Parameter Setting menu.

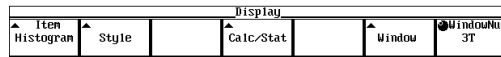

Setting the window mode to multi-window

2. Turn the rotary knob to select [Mode]. Press the SELECT key to select [Multi].

Setting the window size

3. Turn the rotary knob to select [Size].
Press the SELECT key to display the numerical entry area and enter the size with the numerical keys.

Setting the constant T

4. Turn the rotary knob to select [T Value].
Press the SELECT key to display the numerical entry area and enter the value with numerical keys.

Updating the window

5. Turn the rotary knob to highlight [Update to Window].
Pressing the SELECT key updates the center, span, and marker values.

Setting the various values of the window

6. Turn the rotary knob to highlight [Label], [Center], [Left Marker] or [Right Marker] of the appropriate window and enter the value with the numerical keys.
For [Span], pressing the SELECT key after highlighting it displays a selection menu. Turn the rotary knob to select the desired value from the menu.

Selecting the window to display

7. Press the [WindowNum] soft key of the DISPLAY menu.
Turn the rotary knob to select the window to display.

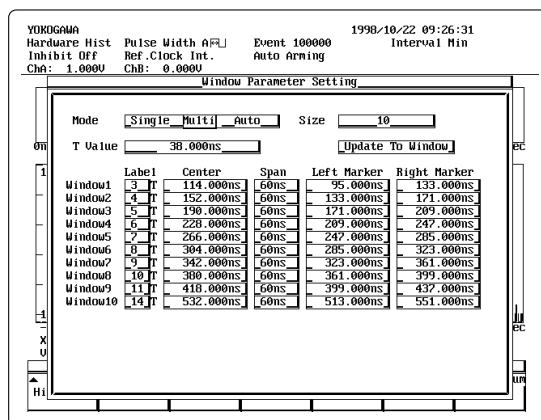

Explanation

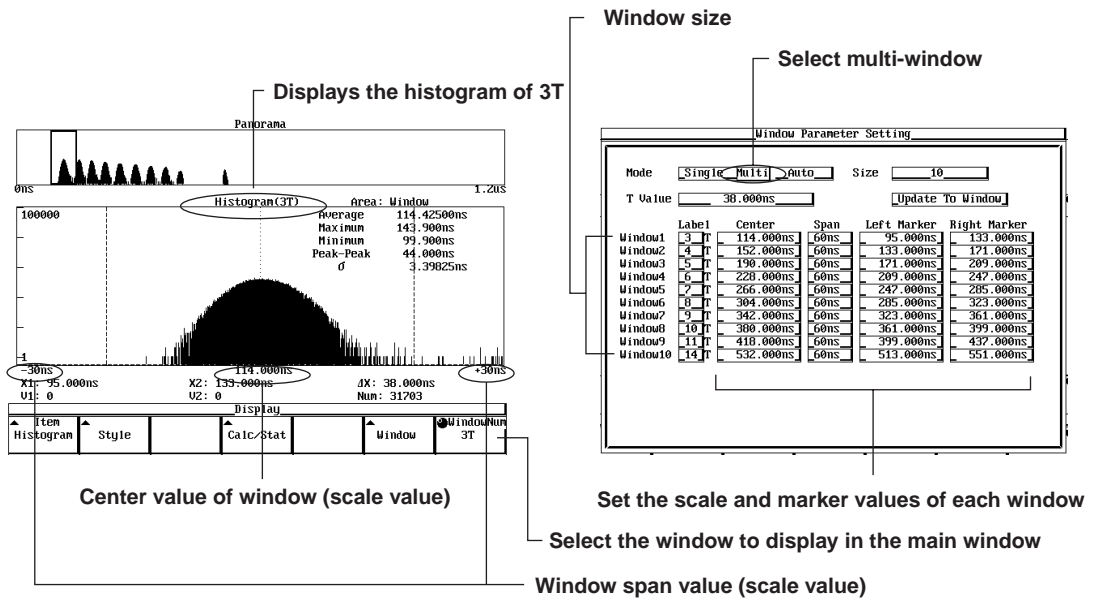

Selecting the window mode

The following three window modes are available.

- **Single** : Use this mode when analyzing the data on one window.
- **Multi** : You can set multiple windows of different sizes. Use this mode when there are multiple histograms and the value of the constant T is known.
- **Auto** : Automatically determines the value of T according to the input data and sets the window size. Use this mode when there are multiple histograms and the value of the constant T is not fixed (CDs of CAV format, for example) or when the constant T cannot be determined. For auto window, see section 8.6.

Setting the window size

Sets the number of windows.
 Selectable range : 1 to 16

Constant T

Sets the interval between the center value of each window (T value).
 Selectable range : 1 ns to 250 ns (in 25 ps steps)

Updating the window

Reflects the value of the constant T to the Center, Span, Left Marker, and Right Marker values of each window.

The values are reflected in the following way.

- Center : $T \times [\text{Label}]$
- Span : A window width closest to but larger than the value T
- Left Marker : $\text{Center} - (T/2)$
- Right Marker : $\text{Center} + (T/2)$

Example If T = 38 ns and the Label of Window1 is 3, then the X-axis settings are as follows:

- Center=38×3=114[ns]
- Span=38(<60)=60[ns]
- Left Marker=114–38/2=95[ns]
- Right Marker=114+38/2=133[ns]

8.5 Using the Multi-Window Function

Setting the X-axis of the window

You can change the settings of the following parameters for each window.

- Label : Window name (Selectable range is 1 to 16)
- Center : Center value
- Span : Window width
- Left Marker : X1 marker position
- Right Marker : X2 marker position

Calculates the statistics in the area enclosed by the Left Marker and Right Marker.

For the ranges of each parameter, see sections 8.8 and 8.9.

Selecting the window to display (WindowNum)

Selects which window to display.

You can select the window that was set in the Window Parameter Setting menu, All, or Summation.

All : Displays the histogram of all windows and lists the statistics of each window.

Summation : Sums the histograms of all windows and displays the result.

When the window is set to ALL

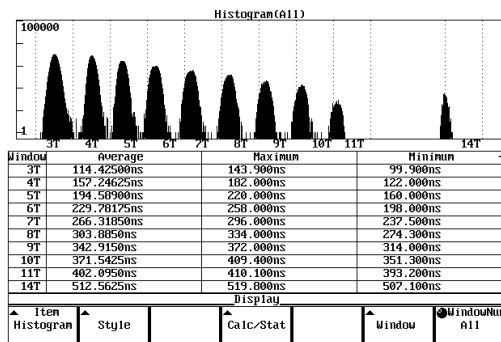

Displays the first three parameters that were turned ON using the [Calc/Stat] soft key.

Note

- The value of Center and Span for each window can be set in the soft key menu that is displayed by pressing the SCALE key.
- The value of Left Marker and Right Marker can be set in the soft key menu that is displayed by pressing MARKER key.

8.6 Using the Auto Window Function

≒For a functional description, see 1.7.≒

Procedure

- Press the DISPLAY key to display the Display menu.
Press the [Window] soft key to display the Window Parameter Setting menu.

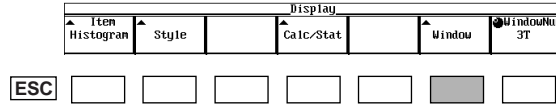

Setting the window mode to auto window

- Turn the rotary knob to select the [Mode] item. Press the SELECT to select [Auto].

Selecting the modulation method

- Turn the rotary knob to select the [Modulation] item.
Press the SELECT key to select [EFM], [EFM+], or [1-7].

Selecting the type of the constant T

- Turn the rotary knob to select [T Type].
Press the SELECT key to select [Measured T] or [Estimated T].

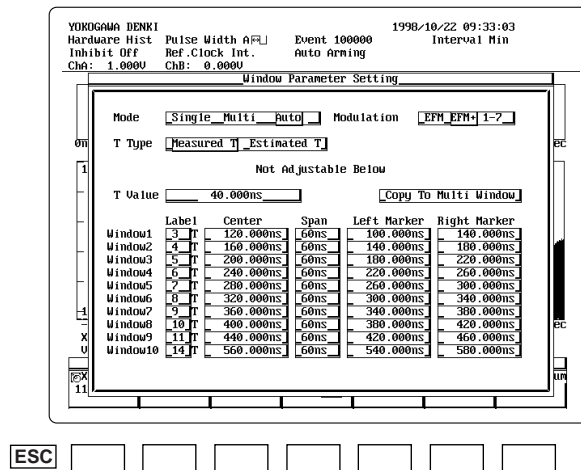

Copying the auto window settings to the multi-window (only for period measurement and pulse width measurement)

- Turn the rotary knob to select [Copy to Multi Window].
Pressing the SELECT key displays the Alert!! menu. Turning the rotary knob to select [OK] and pressing the SELECT key copies the settings such as the center, span, and marker values to the multi-window. Selecting [Cancel] and pressing the SELECT key cancels the copying operation.

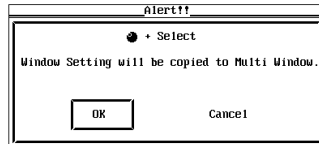

Copying the auto window settings to a single window (only for time interval measurement)

- Turn the rotary knob to select [Copy to Single Window].
Pressing the SELECT key displays the Alert!! menu. Turning the rotary knob to select [OK] and pressing the SELECT key copies the settings such as the center, span, and marker values to the single window. Selecting [Cancel] and pressing the SELECT key cancels the copying operation.

Selecting the window to display

- Press the [WindowNum] soft key
Turn the rotary knob to select the window to display.

Explanation

Selecting the window mode

For details, see section 8.5.

Selecting the modulation method

Select from the following choices.

- EFM : A modulation method used on CDs.
- EFM+ : A modulation method used on DVDs. Sometimes called (8-16) modulation.
- 1-7 : (1-7)RLL modulation method. Used on rewritable disks.

This instrument provides the following windows for each modulation method.

Modulation Method	Window	Window Size
EFM	3T to 11T	9
EFM+	3T to 11T, 14T	10
1-7	2T to 8T	7

Selecting the type of the constant T

Select from the following choices.

- Measured T : Automatically measures the value of the constant T from the clock input signal of CHB.
- Estimated T : Estimates the value of the constant T from the input signal and the modulation method.

Setting the X-axis of the window

Automatically sets the values of the following items from the modulation method and the value of the constant T.

- For period measurement and pulse width measurement
 - Center (Center value) : $T \times [\text{Label}]$
 - Span (Window width) : A window width closest to but larger than the value T
 - Left Marker : $\text{Center} - T/2$
 - Right Marker : $\text{Center} + T/2$
- For time interval measurement
 - Center (Center value) : $T/2$
 - Span (Window width) : A window width closest to but larger than the value T
 - Left Marker : $\text{Center} - T/2$
 - Right Marker : $\text{Center} + T/2$

Note

- The following items in the dialog box cannot be set.
T Value, Label, Center, Span, Left Marker, Right Marker
- For time interval measurements, you can only select [T/2] for [WindowNum]. You cannot select [All] or [Summation].
- When making period or pulse width measurements and the constant T is set to [Measured T], set the measurement channel to CHA.

Copying the auto window settings to multi-window

Copies the X-axis setting that was automatically set based on the measured value of T to the multi-window. Use this function when you wish to make measurements using the value that was automatically measured.

This function is available for period measurement and pulse width measurement.

Copying the auto window settings to a single window

Copies the X-axis setting that was automatically set based on the measured value of T to the single window.

This function is available for time interval measurement.

Selecting the window to display

For details, see section 8.5.

8.7 Setting the Statistical Calculation Parameters (Calc/Stat)

≒For a functional description, see 1.7.≒

Procedure

1. Press the DISPLAY key to display the Display menu.
2. Press the [Calc/Stat] soft key to display the Calculation/Statistics Setting menu.

Setting the calculation area (only for single window)

3. Turn the rotary knob to select the [Calculation Area] item.
4. Press the SELECT key to select [Window] or [Marker].

Setting the constant T

5. Turn the rotary knob to select the [T value] item.
6. Press the SELECT key to display the numerical entry box and set the value using the numerical keys.

Selecting the statistical parameters to calculate

7. Use the rotary knob to select the buttons under [Statistics] and press the SELECT key to check them.
Selecting [All Clear] and pressing the SELECT key removes all the checks.

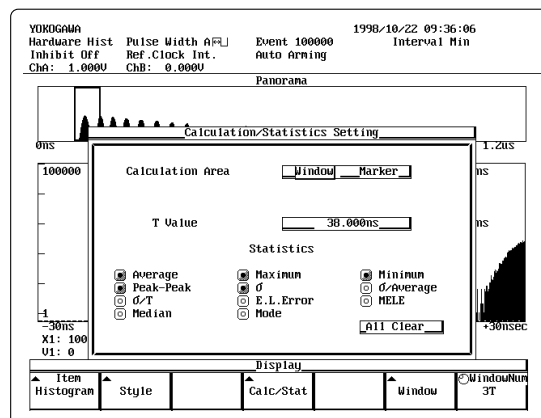

Selecting the calculation polarity (only for A ↑ B ↑, A ↑ B ↓, and ← →)

8. Turn the rotary knob to select the [Calculation Slope]/[Calculation Polarity] item.
9. Press the SELECT key to select one.

Explanation

Setting the statistical calculation area

When using a single window, you can set the area on which to calculate statistics.

- Window: The entire displayed window.
- Marker : The area enclosed by the X1, X2, and Y markers.

Statistical parameters to be calculated

Select from the following choices.

- Average
- Maximum
- Minimum
- Peak-Peak
- σ
- σ/T
- σ /Average
- E.L.Error
- MELE
- Median
- Mode

Constant T (T Value)

Selectable range : 1 ns to 250 ns (in 25 ps steps)

Selecting the calculation polarity (Calculation Slope/Calculation Polarity)

Statistics can be calculated on data having the specified slope or polarity. The histogram corresponding to the specified slope or polarity is displayed in orange; the histogram of both slopes or polarities is displayed in blue.

You can select the slope or polarity only for the following cases:

When the measurement function is set to time interval and the slope is set to

A ↑ B ↑ or A ↓ B ↓

- **A ↑ B ↑** : Calculates the statistics on the data from the rising edge of A to the rising edge of B.
- **A ↓ B ↑** : Calculates the statistics on the data from the falling edge of A to the rising edge of B.
- **A ↓ B ↓** : Calculates the statistics on the data from falling edge of A to the falling edge of B.
- **A ↑ B ↓** : Calculates the statistics on the data from rising or falling edge of A to the rising edge of B.
- **A ↓ B ↑** : Calculates the statistics on the data from rising edge of A to the falling edge of B.
- **A ↑ B ↓** : Calculates the statistics on the data from falling edge of A to the falling edge of B.
- **A ↓ B ↓** : Calculates the statistics on the data from rising or falling edge of A to the falling edge of B.

When the measurement function is set to pulse width and the polarity is set to



- : Calculates the statistics only on the positive side of the waveform.
- : Calculates the statistics only on the negative side of the waveform.
- : Calculates the statistics on both the positive and negative sides of the waveform.

Time interval measurement

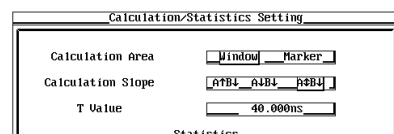

Pulse width measurement

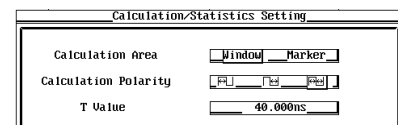

Note

- For multi-window and auto window, the statistical calculation area cannot be selected (set to Marker). The [Calculation Area] item will not be displayed in the dialog box.
- when using the auto window function, the value of the constant T cannot be set.

8.8 Changing the Scale Value

≡For a functional description, see 1.7.≡

Procedure

Executing auto scaling (only for single window)

1. Pressing the AUTO SCALE key executes auto scaling.

Executing manual scaling

1. Press the SCALE key to display the Scale menu.
- **Setting the center value of the X-axis**
 2. Press the [X Center] soft key to set the rotary knob action to [X Center].
Use the rotary knob or numerical keys to set the center value.
- **Selecting the X-axis span**
 3. Press the [X Span] soft key to set the rotary knob action to [X Span].
Turn the rotary knob to select the value.
- **Selecting the maximum value of the Y-axis**
 4. Press the [Y High] soft key to set the rotary knob action to [Y High].
Turn the rotary knob to select the value.
- **Selecting the scale type of Y-axis**
 5. Press the [Y Axis] soft key to select [Lin] or [Log].

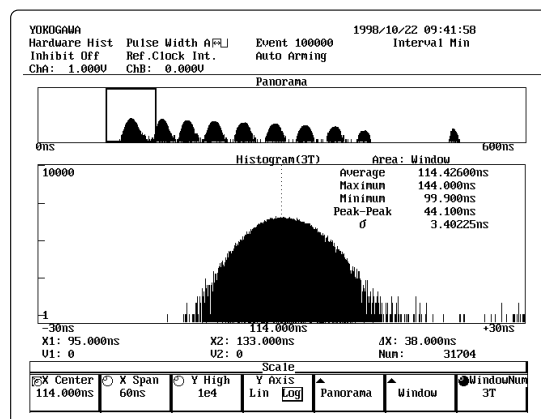

ESC [] [] [] [] [] [] []

Explanation

The instrument provides both auto scaling and manual scaling functions.

Auto scaling

Sets the X- and Y-axes automatically according to the measured data. This can only be used during the single window mode.

Manual scaling

You can arbitrarily set the X- and Y-axis settings.

- **Setting the X- and Y-axis**

Range of center values of the X-axis	: -50.000ns to 3.200000000 μ s (in 25 ps steps)
Selections for the X-axis span	: Select from 1.5/3/7.5/15/30/60/150/300/600 ns, 1.5/3/6 μ s
Selections for the maximum value of the Y-axis	: 10/20/40/100/200/400/1000/2000/4000/10000/20000/40000/100000/200000/400000/1e6/1e7/1e8/1e9(Lin) 1e1/1e2/1e3/1e4/1e5/1e6/1e7/1e8/1e9(Log)
Selections for the scale type of the Y-axis	: Select Lin (linear scale) or Log (logarithmic scale)

Note

You cannot auto scale when using the multi-window or auto window function.

8.9 Reading the Data

≡For a functional description, see 1.6.≡

Procedure

Turning ON/OFF the marker

1. Press the MARKER key to display the Marker menu.
2. Press the [Marker] soft key to select [ON] or [OFF].

Moving the X marker

3. Press the [X Marker] soft key to select [X1] or [X2].
Turn the rotary knob to move the marker.
The measured value and frequency at the position of the marker are displayed in the bottom section of the main window.

Moving the X1 and X2 markers simultaneously

4. Press the [X1&X2] soft key.
Turning the rotary knob causes X1 and X2 markers to move together.

Setting the statistical calculation area (when the calculation area is set to Marker)

5. Press the [Y Marker] soft key.
Use the rotary knob or the numerical keys to set the value.

Selecting the speed of movement of the marker

6. Pressing the [Movement] soft key and selecting ► decreases the speed of movement of the zoom box. Selecting ►► increases the speed of movement.

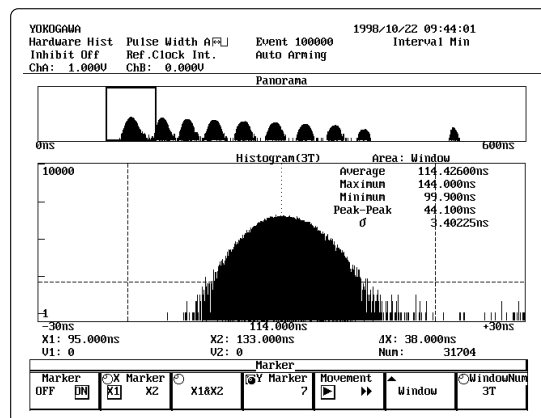

Explanation

Turn ON/OFF the marker

You can read out the data using the marker. The read-out value is displayed in the bottom section of the main window. You can also use the Display key's [Style] to turn ON/OFF the marker and read-out values.

Marker types

X Marker(X1, X2) : Displays the value of the x coordinate (measured value) and the frequency of the X1 and X2 markers.

Y Marker : This marker is used to set the statistical calculation area. This marker becomes effective when the calculation area is set to Marker.

Range of movement of the X1 marker

You can move the marker to the same position as or to the left of the X2 marker.

Range of movement of the X2 marker

You can move the marker to the same position as or to the right of the X1 marker.

Selecting the speed of movement of the marker

▶ : Moves one dot at a time in the window.

▶▶ : Moves five dots at a time in the window.

Range of movement of the Y marker

0 to 1,000,000,000

9.1 Using the Inter-symbol Interference Analysis Function

≒For a functional description, see 1.8.≒

Procedure

Using the inter-symbol interference analysis function.

1. Press the MODE key to display the Measurement Mode Selection Menu.
2. Press the [TimeStamp] soft key.

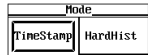

3. Press the FUNCTION key to display the Function menu.
Set the [Function] to [Pulse Width] and the [Polarity] to $\overleftarrow{\text{P}}$.

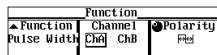

4. Press the DISPLAY key to display the Display menu.
5. Press the [Item] soft key to display the Display Item menu.

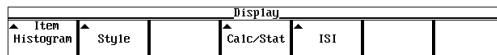

6. Press the [Histogram] soft key.

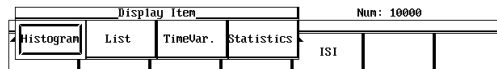

7. Press the [ISI] soft key to display the inter-symbol interference analysis function setting menu.

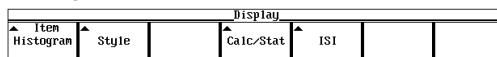

8. Press the [ISI ON/OFF] soft key to select [ON].

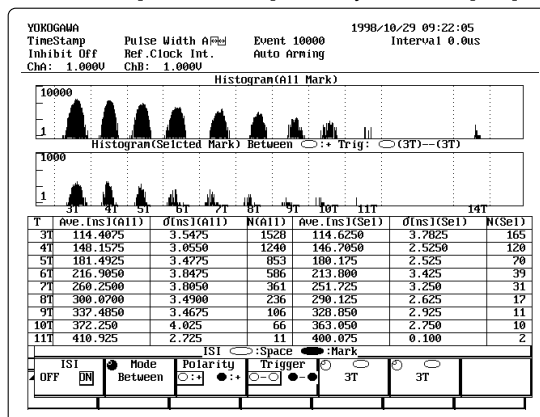

9.1 Using the Inter-symbol Interference Analysis Function

9. When [ISI] is turned [ON], the [Window] soft key appears in the menu of step 4. Press the [Window] soft key and set the value for constant T (T Value). Then, press the [Update to Window] soft key to reflect the value of constant T to the multi-window.
10. Press the START/STOP key to start the measurement.

Explanation

The inter-symbol interference analysis function can be used only in the time stamp mode with the function set to pulse width measurement (polarity set to ) and the display item set to histogram.

When the inter-symbol interference analysis function is turned ON, the window changes to multi-window mode.

Performing the analysis

- The analysis is performed when [ISI] in the inter-symbol interference analysis function menu is switched from OFF to ON.
- The analysis is performed again when the polarity, the trigger condition, the item being analyzed, or other settings are changed.

Note

- The auto window function cannot be used for inter-symbol interference analysis. However, you can determine the scale value beforehand by using the auto window function in the hardware histogram mode and then copy the scale to the multi-window. In this way, you can perform the analysis using the appropriate scale value.
 - If the polarity is changed or the measurement function is set to some function other than pulse width measurement while using the inter-symbol interference analysis function, the inter-symbol interference analysis function turns OFF.
-

9.2 Setting the Conditions for Data Extraction

≒For a functional description, see 1.8.≒

Procedure

Selecting the extraction mode

1. Turn ON the inter-symbol interference analysis function and display the inter-symbol interference analysis function setting menu according to steps 1 through 8 on page 9-1.
2. Press the [Mode] soft key.
Turn the rotary knob to select [Single], [Combination], or [Between].

Selecting the polarity of mark and space

3. Press the [Polarity] soft key to select whether spaces will be positive (○:+) or marks will be positive (●:+).

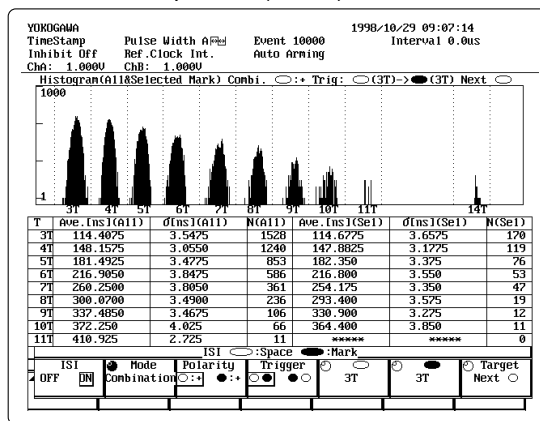

When the extraction mode is set to Single

Selecting the trigger

4. Press the [Trigger] soft key to select or .

Selecting the window that will activate the trigger

5. Press the window setting soft key.
Turn the rotary knob to select the window that will activate the trigger.

Selecting the data to be extracted

6. Press the [Target] soft key.
Turn the rotary knob to select [Prev...], [Next...], or [Both...].



9.2 Setting the Conditions for Data Extraction

When the extraction mode is set to Combination

Selecting the trigger

4. Press the [Trigger] soft key to select or .

Selecting the window to that will activate the trigger

5. Press the window setting soft key.
Turn the rotary knob to select the window to that will activate the trigger.

Selecting the data to be extracted

6. Press the [Target] soft key.
Turn the rotary knob to select [Prev...] or [Next...].

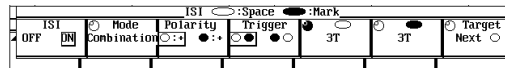

When the extraction mode is set to Between

Selecting the trigger

4. Press the [Trigger] soft key to select - or -.

Selecting the window to that will activate the trigger

5. Press the window setting soft key.
Turn the rotary knob to select the window to that will activate the trigger.

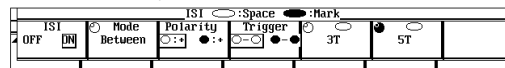

Selecting the parameters to list

7. Press the [Calc/Stat] soft key to display the Calculation/Statistics Setting menu.
8. Use the rotary knob and the SELECT key to check the statistical parameters to list.

Explanation

Selecting the extraction mode

Select from the following choices.

- **Single** : Uses either a space or a mark as the trigger and analyzes the data around it.
- **Combination** : Uses the sequence of a space followed by a mark or a mark followed by a space as the trigger and analyzes the data around it.
- **Between** : When a mark or a space exists between two spaces or two marks it is considered to be a trigger and the data between them are analyzed.







Selecting the polarity



Select whether spaces will be positive (+) or marks will be positive (+).

Selecting the trigger/Selecting the data to be extracted

You can select which mark or space will be used as the trigger. The types of trigger that can be selected vary depending on the extraction mode.

The data around or between triggers can be extracted, but the data that can be extracted vary depending on the extraction mode.

Mode Trigger	Target	Description	
Single		Prev.●/Next●/Both●	Extract the data immediately before or after the trigger or both
		Prev.○/Next○/Both○	
Combination		Prev.●/Next○	Extract the data immediately before or after the trigger
		Prev.○/Next●	
Between		-	Extract the data between two spaces
		-	Extract the data between two marks

 indicates a space;  indicates a mark. On this instrument, you can select which window will be marks and which will be spaces.

Statistical parameters that are listed

The statistics of all marks (spaces) and extracted data and the number of samples are listed.

Select the parameters to list in the following dialog box.

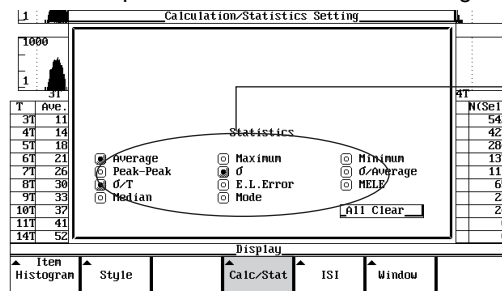

Displays the first two parameters that were checked.

Note during inter-symbol interference analysis

The color assignments on the histogram display are as follows:

Histogram of the extracted data : Orange

Histogram of all spaces or marks : Blue

By turning OFF the [Overlap] function in the [Style] setting of the DISPLAY key, the histogram of the extracted data and that of all spaces or marks can be displayed separately.

9.3 Analysis Example

When the trigger is set to Single (Space)

Analyze the Mark data immediately before the Space(3T)

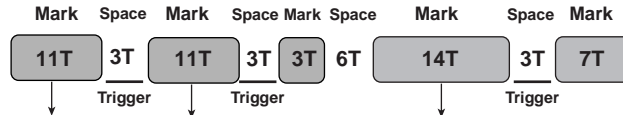

Analyzes the corresponding Mark data.

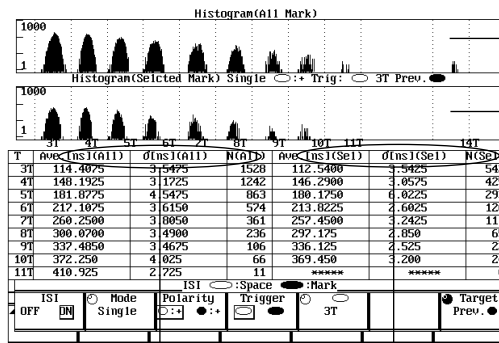

Histogram display of all Mark data

Histogram display of the extracted Mark data

← Sets “the analysis of the Mark data immediately before the Space(3T)”

Statistics of the extracted Mark data

Statistics of all Mark data

When the trigger is set to Combination (Space/Mark)

Analyze the Mark date immediately before the Space(3T) and Mark(7T) sequence.

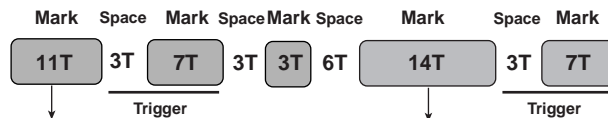

Analyzes the corresponding Mark data.

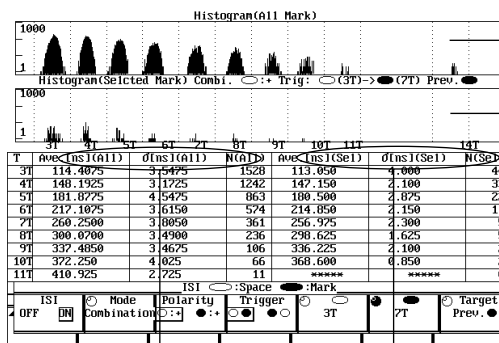

Histogram display of all Mark data

Histogram display of the extracted Mark data

← Sets “the analyze the Mark date immediately before the Space(3T) and Mark(7T) sequence”

Statistics of the extracted Mark data

Statistics of all Mark data

When the trigger is set to Between(Space-Space)

Analyze the Mark data between two Spaces(3T)

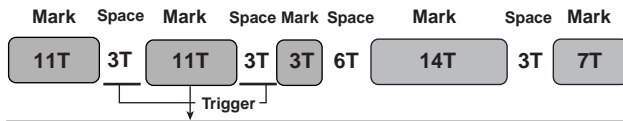

Analyzes the corresponding Mark data.

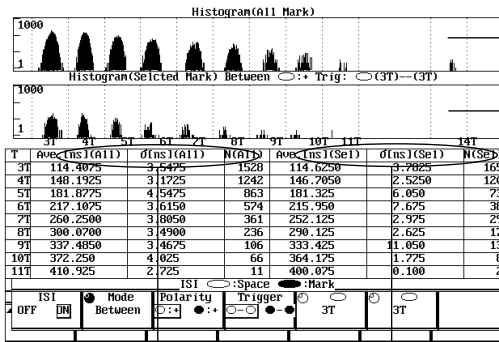

Histogram display of all Mark data

Histogram display of the extracted Mark data

← Sets “the analyze the Mark data between two Spaces(3T)”

Statistics of the extracted Mark data

Statistics of all Mark data

10.1 Storing the Setup Information to the Internal Memory

≒For a functional description, see 1.8.≒

Procedure

1. Press the UTILITY key to display the Utility menu.
2. Press the [Memory] soft key to display the Memory menu.

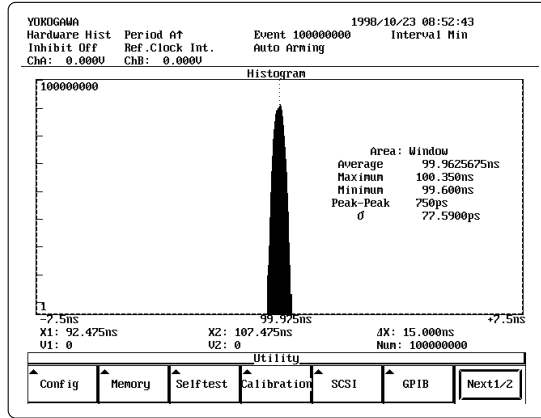

Selecting the memory number

3. Turn the rotary knob to select a memory number.

Storing

4. Press the [Store] soft key to store the setup information.

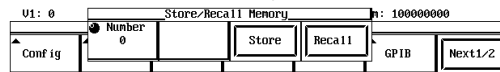

Explanation

Stored information

The measurement conditions and display parameters set using the following keys are stored.

MODE key, FUNCTION key, SAMPLE key, INPUT key, DISPLAY key, SCALE key, MARKER key

Selecting the memory number

Select from the following numbers. If there is setup information already stored in the chosen memory number, it is overwritten (the previous information is lost).

0 to 9

Note

- Initializing the settings will not clear the stored setup information.
- For parameters that are not stored, see page 13-3.

10.2 Recalling Setup Information from the Internal Memory

≒For a functional description, see 1.8.≒

Procedure

1. Press the UTILITY key to display the Utility menu.
2. Press the [Memory] soft key to display the Memory menu.

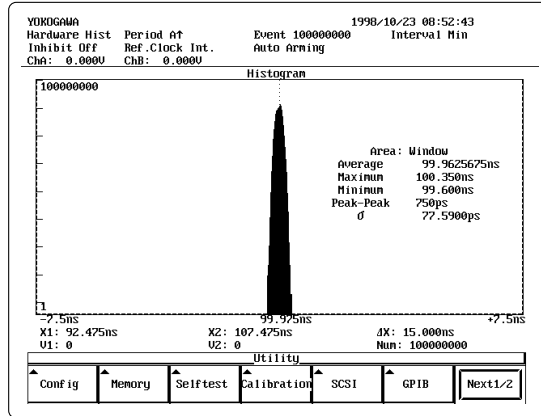

Selecting the memory number

3. Turn the rotary knob to select a memory number.

Recalling

4. Press the [Recall] soft key to recall the setup information.

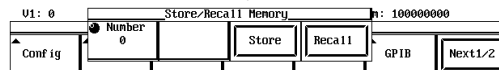

Explanation

Recalled information

Information that was stored is recalled. The current setup information of the instrument is changed to the recalled information.

Selecting the memory number

Select from the following ten memory locations.

0 to 9

11.1 Floppy Disks

Floppy Disks that can be Used

The following types of 3.5-inch floppy disks can be used. The floppy disk can be formatted using the instrument.

- 2HD: 1.2 MB or 1.44 MB (MS-DOS format)
- 2DD: 640 KB or 720 KB (MS-DOS format)

Inserting the Floppy Disk into the Drive

With the label side facing left, insert the floppy disk into the floppy disk drive. Insert the disk until the eject button pops up.

Removing the Floppy Disk from the Drive

Check that the access indicator is OFF, then press the eject button.

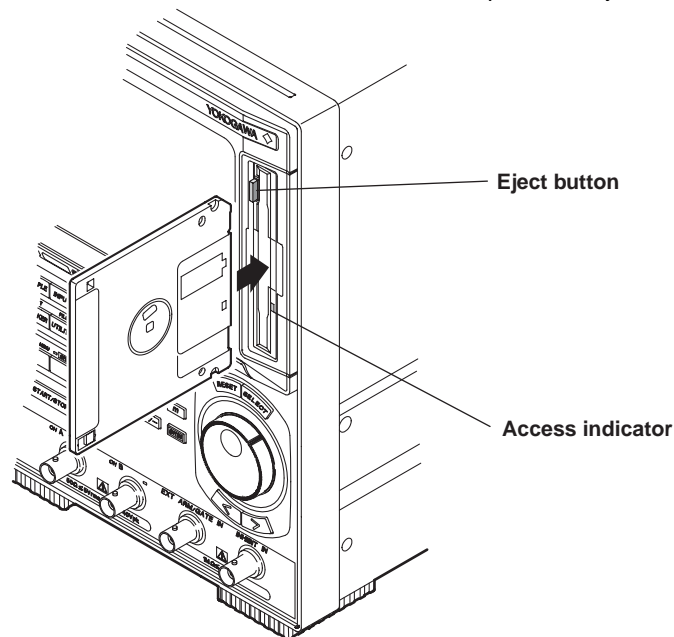

CAUTION

Removing the floppy disk while the access indicator is blinking can damage the magnetic head of the drive and destroy the data on the floppy disk.

General Handling Precautions of the Floppy Disk

For the general handling precautions of the floppy disk, see the instructions that came with the floppy disk.

11.2 Internal Hard Disk (Option)



CAUTION

When using the instrument in an environment with mechanical vibrations, turn OFF the internal hard disk's power switch.

Procedure

Turning ON/OFF the internal hard disk

1. Press the UTILITY key to display the Utility menu.
2. Press the [Config] soft key to display the Configuration menu.

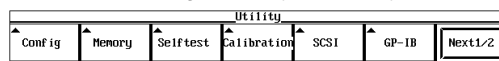

3. Press the [HDD Motor] soft key to select [ON] or [OFF].

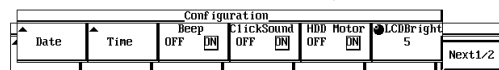

Explanation

The internal hard disk can be turned ON/OFF on this instrument.
You can protect the internal hard disk from vibrations by turning it OFF.

11.3 Connecting SCSI Devices

SCSI Specifications (Option)

Item	Specifications
Interface standard	SCSI(Small Computer System Interface), ANSI X3.131-1986
Connector type	50-pin half pitch (pin type)
Electrical specifications	Single-ended. See the chart below for pin assignments. A terminator is built-in.

Pin No.	Signal Name	Pin No.	Signal Name
1 to 12	GND	38	TEMPWR
13	NC	39, 40	GND
14 to 25	GND	41	-ATN
26	-DB0	42	GND
27	-DB1	43	-BSY
28	-DB2	44	-ACK
29	-DB3	45	-RST
30	-DB4	46	-MSG
31	-DB5	47	-SEL
32	-DB6	48	-C/D
33	-DB7	49	-REQ
34	-DBP	50	-I/O
35 to 37	GND		

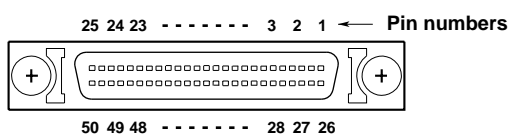

Necessities when connecting a SCSI device

SCSI cable

Use a commercially sold cable that is 3 m or less in length, that has a ferrite core on each end of the cable, and that has a characteristic impedance between 90 and 132 Ω .

Connection Procedure

1. Connect the SCSI cable to the SCSI connector on the back of the instrument.
2. Turn ON the SCSI device and the TA520.

For formatting media, follow the steps given in "11.5 Formatting the Disk".

SCSI devices that can be connected

Most SCSI devices (MO disk drive, hard disk, and ZIP) can be connected to the instrument, but there are some exceptions. For example, only hard disks that have a capacity of 2 GB or less can be used.

Note

When connecting multiple SCSI devices in a chain, attach a SCSI terminator to the device at the other end of the chain.

11.4 Changing the SCSI ID Number

Procedure

Changing the ID number of the instrument or of the internal hard disk

1. Press the UTILITY key to display the Utility menu.
2. Press the [SCSI] soft key to display the SCSI Setting menu.

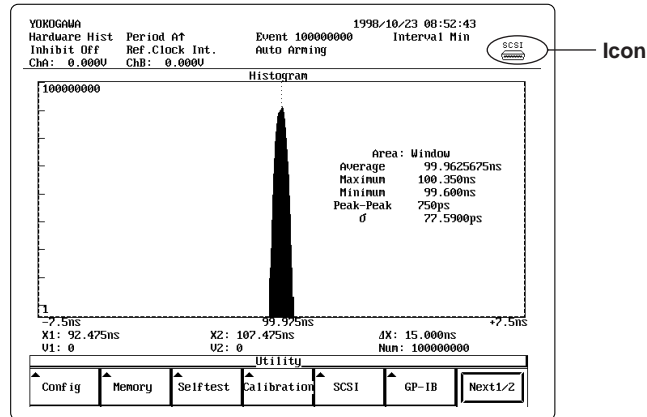

3. Press the [Own ID] or [HD ID] soft key.
Turn the rotary knob to set the ID number.
4. Press the [SCSI Init] soft key to execute the ID number change.
An icon blinks in the upper right corner of the screen while the ID is being changed.
The  icon disappears when the changes are complete.

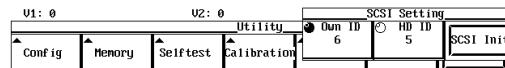

Explanation

The SCSI ID number is used to distinguish between the various devices connected to the SCSI chain.

Make sure not use duplicate ID numbers on any of the connected devices.

The default values are as follows:

Own ID (instrument) : 6

HD ID (internal hard disk) : 5

* Internal hard disk and SCSI are options.

Range of SCSI ID numbers

0 to 7

Precautions on setting the SCSI ID number

- Own ID and HD ID must be different numbers.
- Assign numbers that are different from the ID number of the instrument (default value 6) for the internal hard disk and the external SCSI devices.
- When changing the SCSI ID number, make sure to press the [SCSI Init] soft key.
- The ID numbers of the external SCSI devices are automatically identified.

11.5 Formatting the Disk

Procedure

1. Press the SHIFT+UTILITY(FILE) key to display the File menu.
2. Press the [Utility] soft key.

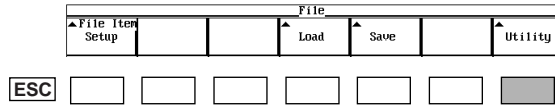

3. Press the [Function] soft key to display the Function menu.

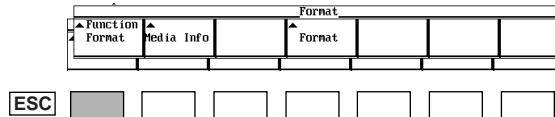

4. Press the [Format] soft key.
Turn the rotary knob to highlight the medium you wish to format.

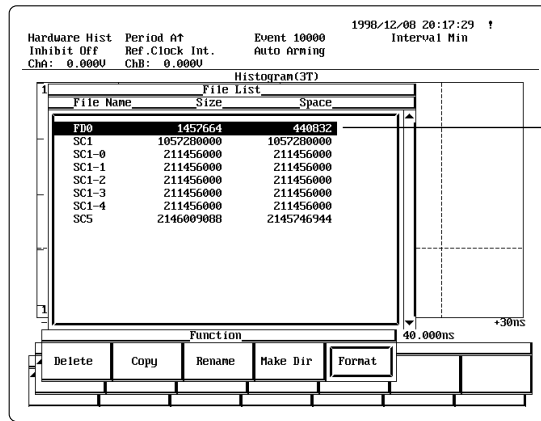

Use the rotary knob to select the medium



Selecting the FD format (for floppy disks only)

5. Press the [FD Format] soft key.
6. Turn the rotary knob to select [2DD 640K], [2DD 720K], [2HD 1.2M], or [2HD 1.44M].

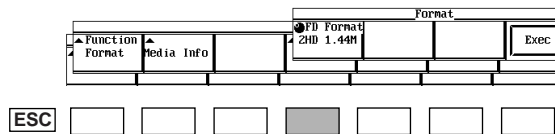

Setting the format type and partition (for SCSI devices only)

5. Press the [Format] soft key.
6. Press the [Format Type] soft key to select [Normal] or [Quick].
7. Turn the rotary knob to set the number of partitions

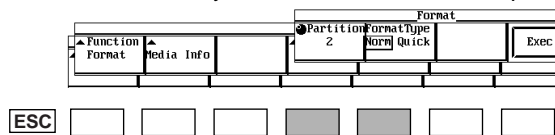

Executing the format operation

8. Press the [Exec] soft key

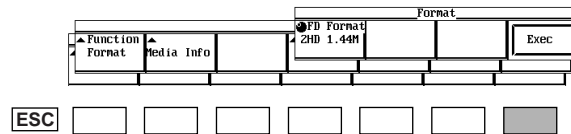

9. The Alert!! menu is displayed. Turning the rotary knob to select [OK] and pressing the SELECT key executes the format operation.

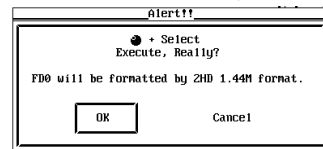

Canceling the format operation

9. The Alert!! menu is displayed. Turning the rotary knob to select [Cancel] and pressing the SELECT key cancels the format operation.

Looking at the information about the medium

10. Pressing the [Media Info] soft key lists the information about the media that is highlighted.

Explanation

CAUTION

- Never remove the disk or turn OFF the power while the format operation is in progress (while the access indicator is blinking). It can damage the medium or destroy the data on the medium.
- When the instrument cannot read a pre-formatted medium, reformat the medium on the instrument. Make sure to back up important data before formatting the medium. All data will be erased.

Displaying free disk space information

The free disk space of an MS-DOS formatted floppy disk is among the information displayed by pressing the [Media Info] key.

Formatting a floppy disk

When using a new floppy disk, you must format it first.

FD format

Select the appropriate format for the floppy disk from the following choices.

- 2DD 640K : Formats the 2DD floppy disk to 640 KB/8 sectors.
- 2DD 720K : Formats the 2DD floppy disk to 720 KB/9 sectors.
- 2HD 1.2M : Formats the 2HD floppy disk to 1.2 MB/8 sectors.
- 2HD 1.44M : Formats the 2HD floppy disk to 1.44 MB/18 sectors.

Formatting a disk

The formats of media connected via SCSI are as follows.

MO/PD : Semi-IBM format. Handled as removable disk.

ZIP/JAZ : Hard disk format. Handled as fixed disk.

Hard disk format

The hard disk format is IBM compatible format.

Selecting the format mode

When formatting a medium in an external SCSI device, the following two format modes are available.

Normal : Executes physical format and logical format.

Quick : Executes only the logical format.

The estimated time needed to format a medium is as follows.

For external HDDs, the time will vary depending on the specifications of the drive such as the rotation speed.

Medium	Normal	Quick	
MO (128 MB)	Approx. 10 min	Approx. 15 s	
MO (230 MB)	Approx. 10 min	Approx. 15 s	
External HDD (1 GB)	Approx. 10 min	Approx. 15 s	The time varies depending on the external hard disk.
Internal HDD	Approx. 5 min	Approx. 15 s	

Setting the partitions

You can set partitions on the external SCSI device and on the internal hard disk.

You can create between one and five partitions.

Listing the information about the medium

The following information is listed for the selected medium.

- Media Name : Name of the medium
- Media Size : Total capacity
- Used Space : Used space
- Vacant Space : Free space
- Partition Size : Number of partitions

Precautions on formatting

- Formatting a medium containing data erases the data completely.
- The time it takes to format a floppy disk is approximately one and a half minutes.
- A floppy disk cannot be formatted if it is write protected.
- Never format when the instrument is connected to a PC via a SCSI cable.

Note

- Floppy disks having a format other than the ones listed above cannot be used.
- If an error message appears after the format operation, the floppy disk may be damaged.
- Disks formatted to MS-DOS format on a PC can also be used.
- The logical (Quick) format only clears the directory entry and FAT information. If you need to check for bad tracks, do a physical format (Normal).
- When data are written to an external SCSI device that has bad tracks, an access error (604 Media failure) may occur in which case no more data can be written. When you are using a medium for the first time or if the medium can no longer be read, do a [Normal] format. If you want to format a disk that you have been using before, do a [Quick] format.
- If you attempt to format a hard disk in a way such that any one partition is larger than 2 GB, an error occurs.

Set the partitions so that they are all less than 2 GB.

11.6 Saving and Loading Setup Information

Procedure

1. Press the SHIFT+UTILITY(FILE) key to display the File menu.
2. Press the [File Item] soft key to display the File Item menu.

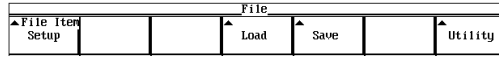

3. Press the [Setup] soft key.

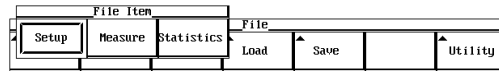

Saving the setup information

Displaying the Save menu

4. Press the [Save] soft key to display the Save menu.

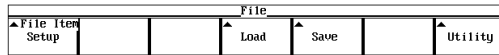

Selecting the directory in which to save the information

5. Press the [File List] soft key to display the File List.

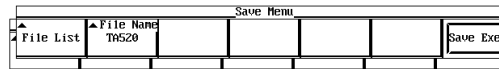

6. Turn the rotary knob to select the medium (displayed with []) and press the SELECT key. Similarly, select the directory (displayed with <>).

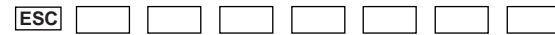
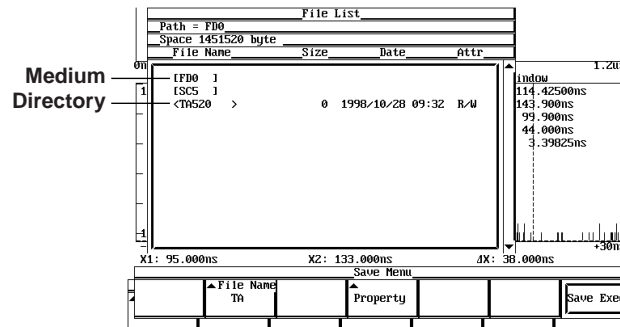

The [Path=.....] displays the selected medium/directory name.

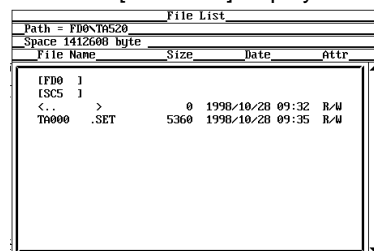

Setting the file name

7. Press the [File Name] soft key to display the Save menu.
8. Turn the rotary knob to select [AutoNaming]. Press the SELECT key to select [ON] or [OFF].
9. Turn the rotary knob to select [File Name] and press the SELECT key.
A keyboard is displayed on the screen. Use the rotary knob and the SELECT key to enter the file name. For the procedure for entering the file name, see section 4.2.
10. Similarly, enter the [Comment].

Saving the file

11. After setting the file name, pressing the [Save Exec] key saves the setup information to the specified directory (the [Save Exec] key changes to an [Abort] key). Pressing the [Abort] soft key cancels the save operation.

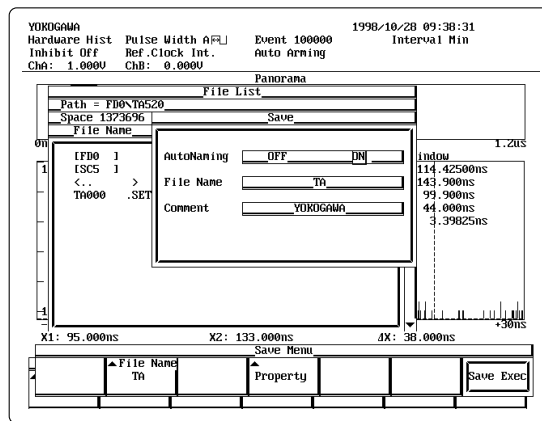

Looking at the properties

12. Pressing the [Property] soft key in the Save menu displays the properties of the file that is selected in the list.

11.6 Saving and Loading Setup Information

Loading setup information

Displaying the Load menu

4. After step 3, press the [Load] soft key to display the File List.

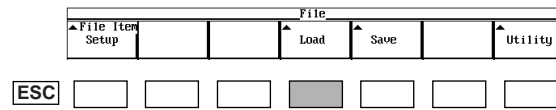

Selecting the directory from which to load the information

5. Turn the rotary knob to select the medium (displayed with []) and press the SELECT key. Similarly, select the directory (displayed with <>). The [Path=.....] displays the selected medium/directory name.

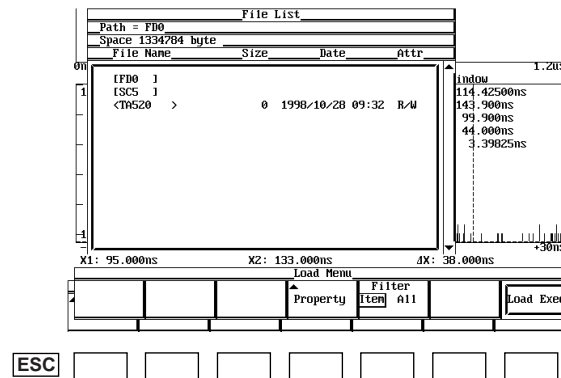

Specifying the file to list

6. Press the [Filter] soft key to select [Item] or [All].

Selecting the file to load

7. Turn the rotary knob to select the file to load.

Loading the file

8. Pressing the [Load Exec] key loads the setup information from the selected file (the [Save Exec] key changes to an [Abort] key). Pressing the [Abort] soft key cancels the loading operation.

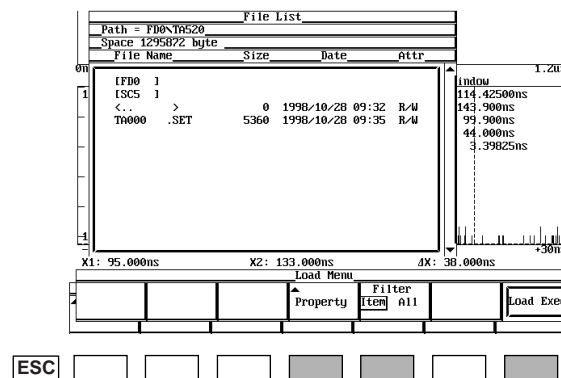

Looking at the properties

9. Pressing the [Property] soft key in the Load menu displays the properties of the file that is selected in the list.

Explanation**Setup information that are saved**

The measurement conditions and display parameters set using the following keys are stored.

MODE key, FUNCTION key, SAMPLE key, INPUT key, DISPLAY key, SCALE key, MARKER key

Selecting the directory

The media that are available are displayed in the File List.

Examples

[FD0] : Floppy disk

[SC5] : SCSI device with an ID number of 5

[SC5-1] : The first partition of a SCSI device with an ID number of 5

File extension

The File extension .SET is appended to the file name.

Data size

The data size corresponding to one set of setup information is approximately 5 KB.

Entering the file name and comments

- The file name should have eight characters or less.
- You cannot save to an existing file (no overwriting).
- You must specify a file name. Comments can be omitted. For details, see section 4.2.

Auto naming function

When [Auto Naming] is turned ON, files with three digit numbers from 000 to 999 are automatically created. Specify the common name (maximum of five characters, specify at the Filename item) that is placed before the three digit number.

Specifying the type of files to list (Filter)

You can specify the type of files to display.

- Item : Displays only setup information files.
- All : Displays all files on the medium.

Properties

Lists the file size, the date it was saved, the attribute, and the comment.

Note

- You cannot save or load while the measurement is in progress (START/STOP indicator is ON).
- If you change the file extension on a PC, for a example, you will not be able to load that file.
- A maximum of 35 characters can be displayed in [Path]. If the directory is changed when the length of the [path] string exceeds 35 characters, an error (601) occurs and the directory cannot be changed.

CAUTION

Removing the medium while the access indicator and  are blinking can damage the magnetic head of the drive and destroy the data on the medium.

11.7 Saving and Loading the Measurement Results

Procedure

1. Press the SHIFT+UTILITY(FILE) key to display the File menu.
2. Press the [File Item] soft key to display the File Item menu.

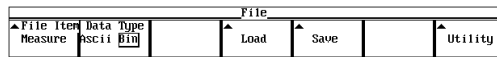

3. Press the [Measure] soft key.

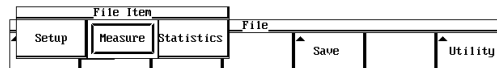

Selecting the data type

4. Press the [Data Type] soft key to select [Ascii] or [Bin].

Saving the measurement results

Selecting the file in which to save the results

5. Press the [Save] soft key to display the Save Menu.

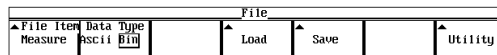

6. Press the [File List] soft key to display the File List.

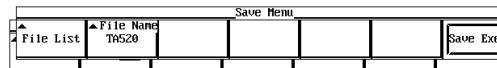

7. Select the medium and directory according to the steps given in "Selecting the directory in which to save the information" in 11.6.
8. Press the [File Name] soft key to display the Save menu.
Enter the file name according to the steps given in "Setting the file name" in 11.6.

Saving the file

- After setting the file name, pressing the [Save Exec] key saves the measured data to the specified directory (the [Save Exec] key changes to an [Abort] key). Pressing the [Abort] soft key cancels the save operation.

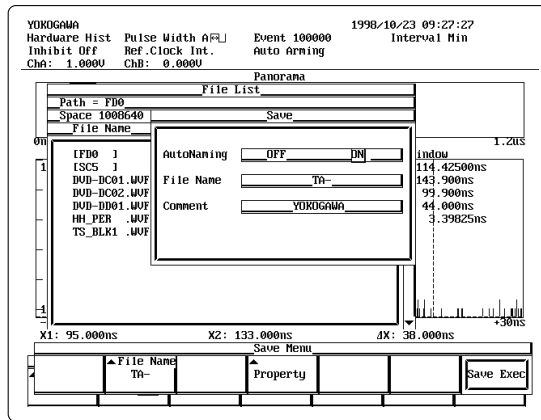

Loading the measurement results

Displaying the load menu

- After step 4 (only Bin files can be loaded), press the [Load] soft key to display the File List.

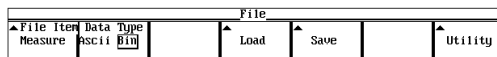

Specifying the files to list

- Press the [Filter] soft key to select [Item] or [All].

Selecting the file to load

- Select the medium and directory according to the steps given in "Selecting the directory from which to load the information" in 11.6.
- Select the file name according to the steps given in "Selecting the file to load" in 11.6.

11.7 Saving and Loading the Measurement Results

Loading the file

- Pressing the [Load Exec] key loads the measurement results (binary data) from the selected file (the [Save Exec] key changes to an [Abort] key). Pressing the [Abort] soft key cancels the loading operation.

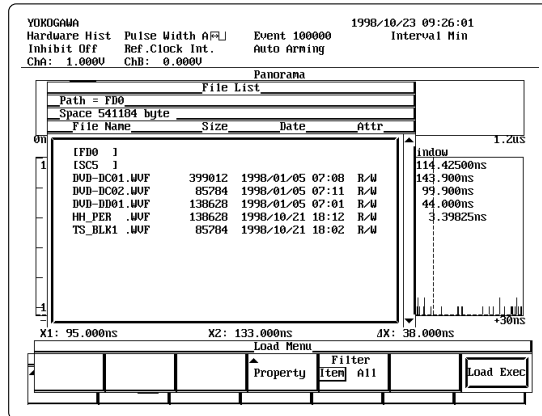

Explanation

Selecting the data type

Select from the following choices.

Bin

Saves the measured data in binary format. You can load the data after saving them.

Ascii

- During hardware histogram mode:
 - Saves the values (class values) and frequencies within the window of the histogram display in text format. The data cannot be re-loaded after they are saved.
- During time stamp mode:
 - Saves all of the data (time stamps and values) of the measurement block in text format. The data cannot be re-loaded after they are saved.

File extension

The file extension is different for each data type. It is automatically appended to the file.

- Bin : The file extension is .WVF. A header file in ASCII format is also saved. The header file contains important information that is needed when analyzing the measured data.
- Ascii : The file extension is .ASD.

Specifying the files to list

You can specify the type of files to display.

- Item : Displays only measurement result files.
- All : Displays All files on the medium.

Data size

The data size varies depending of the number of samples (S) and the data type.

Bin

- Data measured in the hardware histogram mode:

Expressing the absolute value of the difference between the maximum value and the minimum value of the measured data as P-P, the data sizes are as follows. The values inside parentheses are the data sizes for time interval measurements (**A** ↑ **B** ↑ or **A** ↓ **B** ↓) and fixed pulse width (**F** ↑ **F** ↓).

P-P ≤ 800 ns : Approx. 136 KB (395KB)

800 ns < P-P ≤ 1.6 μs : Approx. 272 KB (790 KB)

1.6 μs < P-P ≤ 2.4 μs : Approx. 408 KB (1185 KB)

2.4 μs < P-P : Approx. 544 KB (1580 KB)

- Data measured in the time stamp mode: Approx. 8xS +5 KB

Ascii

The data size varies greatly depending on the sampling mode, sampling size, and histogram settings. The maximum size is approximately 15 MB.

Properties

Lists the file size, the date it was saved, the attribute, and the comment.

Note

- You cannot save or load while the measurement is in progress (START/STOP indicator is ON).
- The measured data saved in ASCII (text) format cannot be re-loaded.
- When measurement data are loaded, the setup information of the instrument changes to the setup information included with the measured data.
- If you change the file extension on a PC, for a example, you will not be able to load that file.

CAUTION

Removing the medium while the access indicator and  are blinking can damage the magnetic head of the drive and destroy the data on the medium.

11.8 Saving the Statistical Calculation Results

Procedure

1. Press the SHIFT+UTILITY(FILE) key to display the File menu.
2. Press the [File Item] soft key to display the File Item menu.

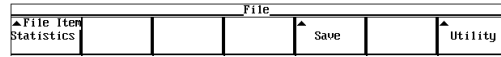

3. Press the [Statistics] soft key.



Selecting the data type (during time stamp mode only)

4. Press the [Stat Item] soft key to select [Hist] or [T.V.].



6. Select the medium and directory according to the steps given in "Selecting the directory in which to save the information" in 11.6.
7. Press the [File Name] soft key to display the Save menu. Enter the file name according to the steps given in "Setting the file name" in 11.6.

Saving the file

8. After setting the file name, pressing the [Save Exec] key saves the measured data to the specified directory (the [Save Exec] key changes to an [Abort] key). Pressing the [Abort] soft key cancels the save operation.

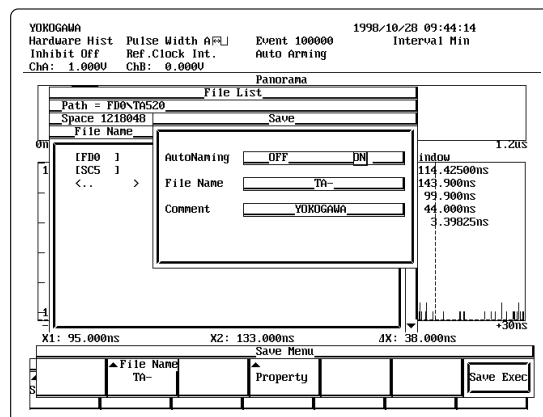

Explanation**File extension**

The File extension .csv is appended to the file name.

Data size**For time stamp mode**

Histogram statistics : 1 KB

Time variation statistics (No block sampling) : 1 KB

Time variation statistics (Block sampling) : 8 KB maximum (when the number of blocks is 100)

For hardware histogram mode

Single window : 1 KB

Multi-window/auto window : 3 KB maximum (when window size is 16)

Entering the file name

See section 11.6.

Note

- You cannot save while the measurement is in progress (START/STOP indicator is ON).
- The statistical calculation results cannot be re-loaded.

Properties

Lists the file size, the date it was saved, the attribute, and the comment.

CAUTION

Removing the medium while the access indicator and  are blinking can damage the magnetic head of the drive and destroy the data on the medium.

11.9 Deleting Files

Procedure

Displaying the Delete menu

1. Press the SHIFT+UTILITY(FILE) key to display the File menu.
2. Press the [File Item] soft key to display the File Item menu.

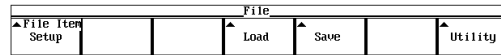

3. Press the [Function] soft key to display the Function menu.

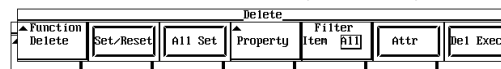

4. Press the [Delete] soft key to display the File List and Delete menu.

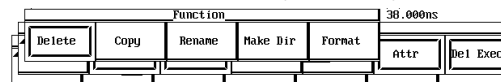

Specifying the files to list

5. Press the [Filter] soft key to select [Item] or [All].

Displaying the files

6. Select the medium and directory according to the steps given in "Selecting the directory in which to save the information" in 11.6.

Selecting the file to delete

7. Turn the rotary knob to select the file you wish to delete and press the [Set/Reset] soft key. The [*] mark appears in front of the file name. If you press the same key again, the [*] mark disappears.

Selecting all files to be deleted

8. Press the [All Set] soft key to place [*] marks in front of all file names (the name of the soft key changes to [All Reset]). If you press the [All Reset] key, the [*] marks disappear.

Deleting the files

9. Pressing the [Del Exec] soft key deletes all files that have [*] marks.

Setting the file attributes

- Turn the rotary knob to select the desired file and press the [Attr] soft key to select [R] or [R/W].

Mark the files to delete

File List

Path = F00
Space 1164800 byte

File Name	Size	Date	Attr
[F00]			
[SCS]			
* DUD-DC01.WVF	399012	1998-01-05 07:08	R/W
* DUD-DC01.HDR	1729	1998-01-05 07:08	R/W
* DUD-DC02.HDR	1259	1998-01-05 07:11	R/W
* DUD-DC02.WVF	85784	1998-01-05 07:11	R/W
* DUD-DB01.HDR	1117	1998-01-05 07:01	R/W
* DUD-DB01.WVF	138628	1998-01-05 07:01	R/W
HH_PER .HDR	1113	1998-10-21 18:12	R/W
HH_PER .WVF	138628	1998-10-21 18:12	R/W
TR520000.HDR	1117	1998-01-05 06:11	R/W
TS_BLK1 .HDR	1255	1998-10-21 18:02	R/W
TS_BLK1 .WVF	85784	1998-10-21 18:02	R/W

Window

X1: 95.000ns X2: 133.000ns ΔX: 38.000ns

Delete

Function: Delete Set/Reset All Set Property Filter Item [Attr] Del Exec

ESC

Note

If the WVF file is deleted when [Filter] is set to [Item], the HDR file is also deleted.

Explanation

Deletes the files that are saved on the floppy disk, internal hard disk, or external SCSI device.

Selecting the files to list (Filter)

You can specify the type of files to list.

- Item : Displays only the files that are specified in the [File Item] menu (Setup, Measure, or Statistics)
- All : Displays all files on the medium.

Setting the file attribute

You can set the attribute for each file. The following two attributes can be specified.

- R/W : Read and write possible
- R : Read only

Changing the attribute to [R] prohibits the file from being deleted. For files you do not wish to delete, set the attribute to [R].

Selecting the files to delete

Deletes all files that have [*] marks in front of them.

Properties

Lists the file size, the date it was saved, the attribute, and the comment.

Note

- You cannot delete files while the measurement is in progress (START/STOP indicator is ON).
 - Files that are deleted cannot be recovered. Make sure not to delete files by mistake.
 - Directories can be deleted if they do not contain files.
 - If an error occurs while deleting multiple files, the files after the error are not deleted.
 - Directory attributes cannot be changed.
-

CAUTION

Removing the medium while the access indicator and  are blinking can damage the magnetic head of the drive and destroy the data on the medium.

11.10 Copying Files

Procedure

Displaying the copy menu

1. Press the SHIFT+UTILITY(FILE) key to display the File menu.
2. Press the [File Item] soft key to display the File Item menu.

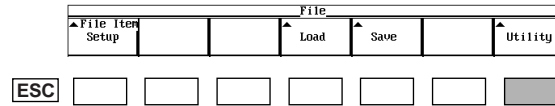

3. Press the [Function] soft key to display the Function menu.

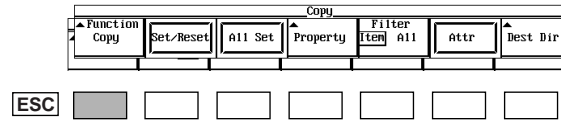

4. Press the [Copy] soft key to display the File List and Copy menu.

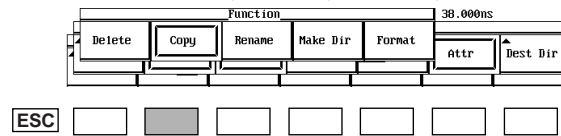

Specifying the files to list

5. Press the [Filter] soft key to select [Item] or [All].

Displaying the files

6. Select the medium and directory according to the steps given in "Selecting the directory in which to save the information" in 11.6.

Selecting the file to copy

7. Turn the rotary knob to highlight the file you wish to copy and press the [Set/Reset] soft key. The [*] mark appears. If you press the same key again, the [*] mark disappears.

Selecting all files to be copied

8. Press the [All Set] soft key to place [*] marks in front of all file names (the name of the soft key changes to [All Reset]). If you press the [All Reset] key, the [*] marks disappear.

Selecting the destination medium and directory

- Press the [Dest Dir] soft key to display the File List and Copy menu.

Mark the files to be copied

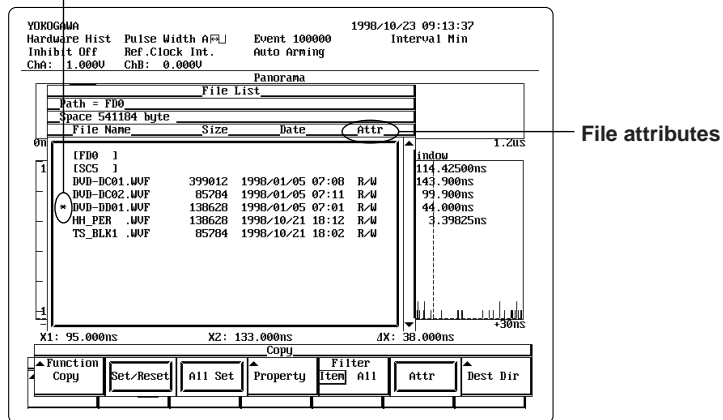

- Select the destination medium and directory according to the steps given in "Selecting the directory in which to save the information" in 11.6.

Copying the files

- Pressing the [Copy Exec] soft key copies the files.

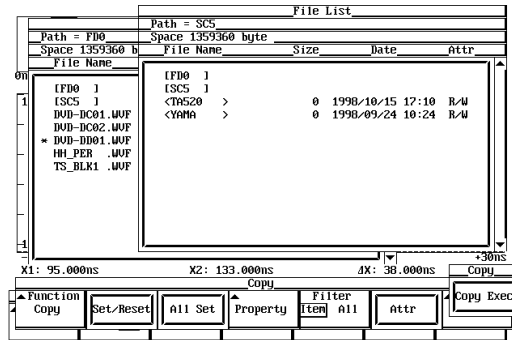

Setting the file attributes

- Turn the rotary knob to highlight the desired file and press the [Attr] soft key to select [R] or [R/W].

Explanation

Copies the files that are saved on the floppy disk, internal hard disk, or external SCSI device to the specified medium.

Selecting the files/properties to list (Filter)

See section 11.9.

File attribute

You can set the attribute for each file. The following two attributes can be specified.

- R/W : Read and write possible
- R : Read only

Note

- You cannot copy files while the measurement is in progress. Press the START/STOP key to stop the measurement.
- If an error occurs while copying multiple files, the files after the error are not copied.
- Directory attributes cannot be changed.
- If a file with the same name exists at the destination, copying is not allowed.
- You cannot copy the same files to another directory immediately after copying those files. You must again select the files you wish to copy.
- If the WVF file is copied when [Filter] is set to [Item], the HDR file is also copied.

11.11 Changing the File Name and Creating Directories

Procedure

Changing the file name

Display the Rename menu

1. Press the SHIFT+UTILITY(FILE) key to display the File menu.
2. Press the [File Item] soft key to display the File Item menu.

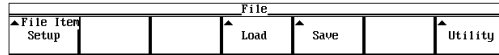

3. Press the [Function] soft key to display the Function menu.

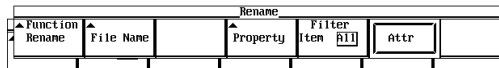

4. Press the [Rename] soft key to display the File List and Rename menu.

Specifying the files to list

5. Press the [Filter] soft key to select [Item] or [All].

Displaying the files

6. Select the medium and directory according to the steps given in "Selecting the directory in which to save the information" in 11.6.

Selecting the file to rename

7. Turn the rotary knob to highlight the file you wish to rename.

Setting the new file name

8. Press the [File Name] soft key to display the keyboard screen.
Enter the file name according to the steps given in 4.2.
Pressing the [Enter] key changes the file name.

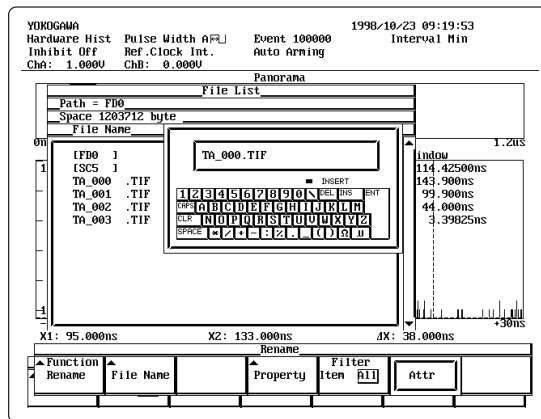

Creating a directory

Display the Make dir menu

- After step 3, press the [Make Dir] soft key to display the File List and Make Dir menu.

Selecting the directory

- Select the medium (directory) according to the steps given in "Selecting the directory in which to save the information" in 11.6.

Setting the directory name

- Press the [Dir Name] soft key to display the keyboard screen. Enter the file name according to the steps given in 4.2. Pressing the [Enter] key changes the file name.

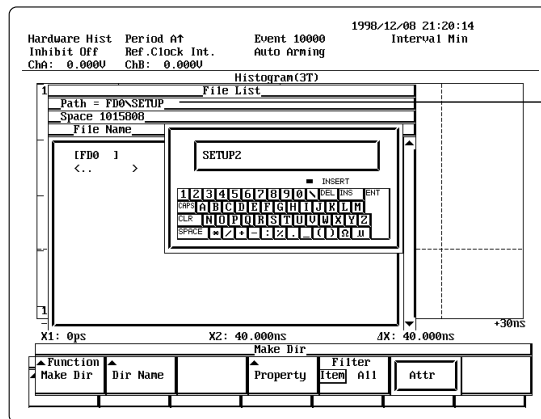

Create <SETUP2> directory in the F00/SETUP directory.



Explanation

Changing the file name

You can change the file name.

Creating directories

Creates a directory on the floppy disk, internal hard disk, or external SCSI device.

Note

- You cannot create directories while the measurement is in progress. Press the START/STOP key to stop the measurement.
- If a file with the same name exists in the directory, you cannot change to that file name.
- If a directory with the same name exists in the directory, you cannot create it.
- If the name of the WVF file is changed when [Filter] is set to [Item], the name of the HDR file is also changed.

11.12 Connecting the Instrument to a PC

A PC will be able to access the internal hard disk (option) of the instrument if a SCSI cable is used to connect the PC to the SCSI (option) of the instrument.

Necessities for connection

SCSI cable (50-pin half pitch, pin type)

Use a commercially sold cable that is 3 m or less in length, that has a ferrite core on each end of the cable, and that has a characteristic impedance between 90 and 132 Ω .

Connection procedure

Changing the ID number of the instrument or the internal hard disk

Before connecting to a PC, change the SCSI ID numbers of the instrument and the internal hard disk so that they do not overlap with the ID numbers of other SCSI devices and the PC.

1. Press the UTILITY key to display the Utility menu.
2. Press the [SCSI] soft key to display the SCSI Setting menu.
3. Press the [Own ID] or [HD ID] soft key.
Turn the rotary knob to set the ID number.
4. Press the [SCSI Init] soft key to change the ID number.



CAUTION

Make sure to follow the connection procedures given below ("Connecting the instrument and PC"). Otherwise, the media of other SCSI devices connected to the PC can be damaged.

Connecting the instrument and PC

1. Turn OFF the instrument and PC.
2. Connect the instrument and PC with the SCSI cable.
3. Turn ON the instrument first.
4. Check that the internal hard disk can be accessed. (Press the [Utility] soft key of the FILE key and display the file list.)
5. Turn ON the PC.

Precautions during connection

- **Files that should not be deleted**

When the internal hard disk is formatted with the instrument, the following files are created in the root directory. Do not delete these files.

If you delete these files, reformat the disk with the instrument.

/AUTORUN.INF

/TA520.ICO

- **Newly created files during connection**

Sometimes when a new file is created with the instrument while the instrument and PC are connected, the PC does not recognize the new file.

In such cases, reconnect the instrument and PC according to the steps given in [Connecting the instrument and PC].

However, if you are running Windows 95, the following steps can be taken so that the file is recognized.

1. On Windows 95, open the [Settings] tab of the drive's properties and check the removable* box.

2. Reboot Windows 95.

3. After creating a new file with the instrument, select [Refresh] from the Explorer's view menu.

* Select the connected drive in the drive list that appears by selecting [My Computer] – [Control Panel] – [System] – [Device Manager] – [Disk drives]. Double-clicking the drive and clicking the [Settings] tab displays the [Removable] check box. You can also check the drive letter at the [Current drive letter assignment].

- **Drive letters**

If multiple hard disks are connected to the PC or if one hard disk is partitioned into multiple drives, connecting the instrument may change the drive letters (D:, E:, etc.) of those drives. For details, see the instruction manual for the PC or of the drive.

You cannot change the drive letter of the instrument.

Example

- PC has one internal HDD

Before connecting the instrument C : (HDD)

After connecting the instrument C : (HDD)

D : (the instrument)

- PC has two internal HDDs

Before connecting the instrument C : (HDD)

D : (HDD)

After connecting the instrument C : (HDD)

D : (the instrument)

E : (HDD)

In actuality, the letter assignments vary depending on the way the hard disks are partitioned, the interface types (IDE, SCSI, etc.), and the drive types.

Note

The instrument can only be connected to the end of the SCSI chain. The internal hard disk of the instrument has a built-in terminator.

12.1 Attaching the Paper Roll for Printing

Paper Roll for Printing

The printer uses a dedicated roll of paper provided by YOKOGAWA. Do not use any other type of paper roll. When using the printer for the first time, use the roll of paper that is included in the package. Order extra rolls from your nearest YOKOGAWA dealer as listed on the back cover of this manual.

Part No. : B9850NX
Specifications : Thermal-sensitive paper, 30 m
Sold in Packs of : 5 rolls

Handling the Roll of Paper

The paper is a thermal-sensitive paper that changes color with the application of heat. Take note of the following points.

Storage precautions

The paper starts changing color at around 70°C. It is affected by heat, humidity, light, and chemicals regardless of whether the paper has been used or not. Note the following points.

- Store the paper in a cool, dry, and dark place.
- After opening the package, use it quickly.
- If the paper is left in contact for long periods of time with plastic film (such as a vinyl chloride film or Scotch tape) containing plasticizers, the paper will lose some of its ability to reproduce color. As a result, for example, if you are going to store the paper in a folder, use a folder made of polypropylene.
- When using glue on the paper, do not use a glue containing organic solvents such as alcohol or ether, as they will change the color of the paper.
- For prolonged storage, we suggest you copy the roll chart. Due to the characteristics of the thermal-sensitive paper, the recording section may lose color over time.

Precautions on use

- Use only rolls of paper provided by YOKOGAWA.
- Touching the paper with sweaty hands can leave finger print marks or blur the printing.
- Rubbing the surface with a hard object can cause the paper to change color due to the heat caused by friction.
- If chemicals, oil, or other liquids come in contact with the paper, the paper may change color or the printing may fade.

12.1 Attaching the Paper Roll for Printing

Installing the Paper Roll

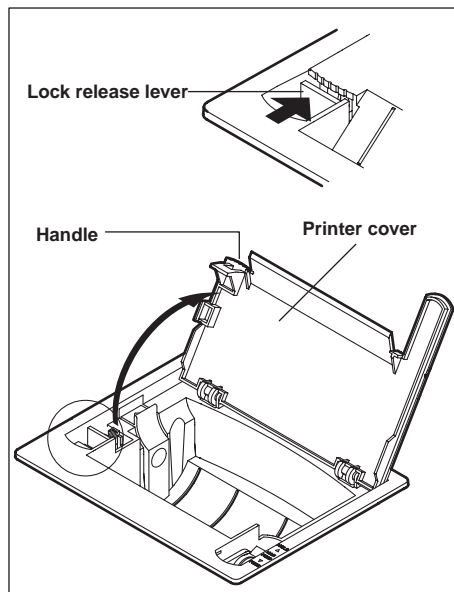

While pressing the lock release lever towards [OPEN], pull up on the handle on the left side of the printer cover to open it.

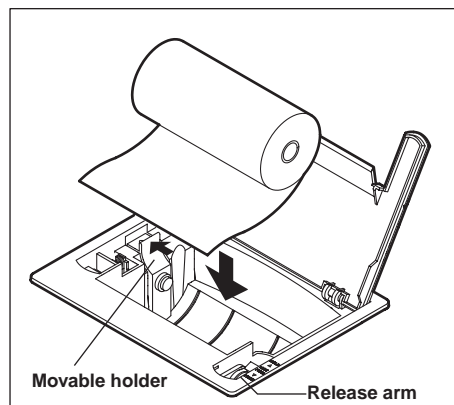

Move the release arm located near the right front to the [MAN FEED] position. Hold the roll of paper so that the inside of the paper (not the glossy side) is facing up. While pressing the movable holder on the left side of the roll storage space to the left, set the core in the right holder. Then, release the movable holder.

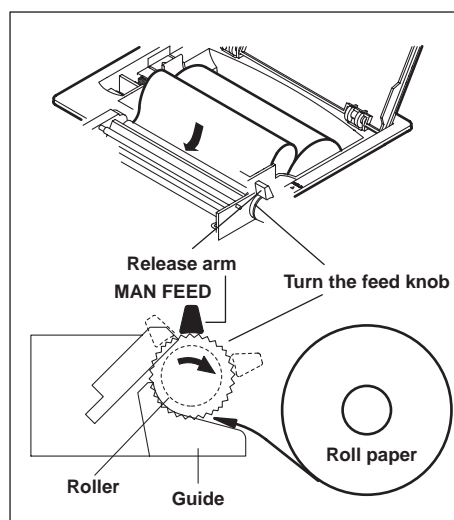

Insert the tip of the roll paper in the space between the roller and the black guide and turn the feed knob away from you until 10 cm of the roll paper is showing at the top of the roller.

12.1 Attaching the Paper Roll for Printing

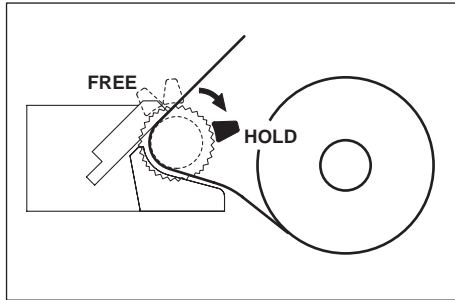

Move the release arm to the [Free] position and straighten the roll paper. Then, move the release arm to the [HOLD] position.

If the release arm is not in the [HOLD] position, an error message will be displayed at the time of printing. In this case, you will not be able to print.

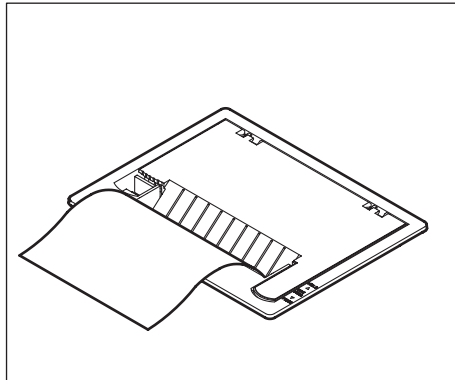

Move the printer cover from the back to the front and close the cover. Make sure that the tip of the roll sheet is showing from the opening in the printer cover. When closing the printer cover, press the cover firmly until it clicks.

Note

After the paper roll is installed, follow the steps on the next page to check that the paper is feeding properly. If it is not feeding evenly, continue to feed the paper for another 30 cm. The paper will straighten out.

12.2 Printing

Procedure

Selecting the printer

1. Press the SHIFT+COPY(COPY MENU) key to display the Copy menu.
2. Press the [Copy to] soft key to display the Copy Destination menu.

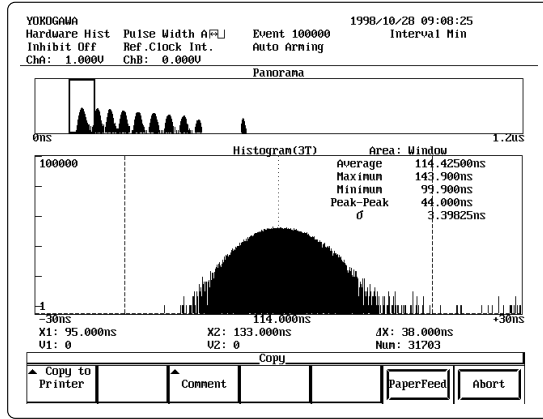

3. Press the [Printer] soft key to set the output destination to the printer.

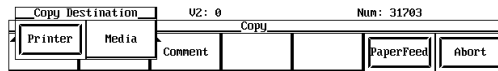

Feeding the chart

4. Press the [Paper Feed] soft key to feed the chart.

Setting comments

5. Press the [Comment] soft key to display the keyboard screen.
6. Enter a comment according to the steps given in "Setting the file name" in 11.6.

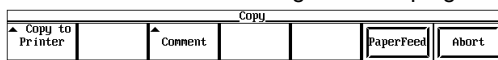

Printing

7. Display the screen that you wish to print.
8. Press the START/STOP key to stop the data acquisition.
Data acquisition is in progress while the indicator on the key is blinking.
9. Pressing the COPY key makes a hard copy of the screen.
To cancel the printing, press the [Abort] soft key in the Copy menu.

Explanation**Comments**

Comments (25 characters or less) are displayed in the top left section of the screen. They can be printed along with the waveform.

Paper feed

You can feed the paper when checking to see whether the roll of paper is properly installed or when you want to skip over a dirty section.

Note

-
- You cannot print while the measurement is in progress (START/STOP indicator is ON).
 - You cannot feed the chart while the measurement is in progress.
 - When the waveforms are overlapped, the color of the waveform on the screen temporarily changes during printing.
-

12.3 Saving Screen Images to Floppy Disk, Internal Hard Disk (Option), and External SCSI Device

Procedure

Selecting the medium

1. Press the SHIFT+COPY(COPY MENU) key to display the Copy menu.
2. Press the [Copy to] soft key to display the Copy Destination menu.

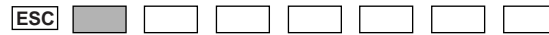
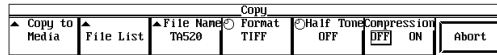

3. Press the [Printer] soft key to set the output destination to media.

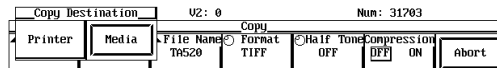

Selecting the destination directory

4. Press the [File List] soft key to display the File List.
Select the directory according to the steps given in "Selecting the directory in which to save the information" in 11.6.

Setting the file name and comment

5. Press the [File Name] soft key to display the Save menu.
6. Enter characters in [Auto Naming], [File Name], and [Comment] according to the steps given in "Setting the file name" in 11.6.

Selecting the output data format

7. Press the [Format] soft key.
Turn the rotary knob to select [TIFF], [BMP], or [PostScript].

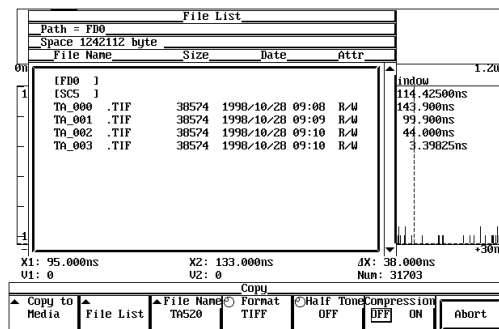

Selecting half tone (only for TIFF and BMP)

- 8. Press the [Half Tone] soft key.
Turn the rotary knob to select [ON(Gray)], [ON(Color)], [ON(ColorR)], or [OFF].

Compressing the data (only for TIFF and BMP)

- 9. Press the [Compression] soft key to select [ON] or [OFF].

Saving

- 10. Set the screen to the screen you wish to save.
- 11. Press START/STOP to stop the measurement. The measurement is stopped when the indicator on the key is turned OFF.
- 12. Pressing the COPY key saves the image to the specified medium. To cancel the save operation, click the [Abort] soft key in the Copy menu.

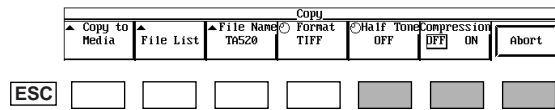

12.3 Saving Screen Images to Floppy Disk, Internal Hard Disk (Option), and External SCSI Device

Explanation

The screen image can be saved to the floppy disk, the internal hard disk (option), or to an external SCSI device.

Selecting the output destination

For the procedure to select the medium and directory, see "Selecting the directory to save the information" in section 11.6.

Output data format

The following formats are available for saving the image data to the medium. The file extension that is automatically appended to the file and the file size (half tone OFF, no compression) are indicated below.

Data format	Extension	File Size
TIFF	*.TIF	Approx. 38 KB (Approx. 302 KB)
BMP	*.BMP	Approx. 38 KB (Approx. 302 KB)
PostScript	*.PS	Approx. 78 KB

The file size inside parentheses is the size when half tone is turned ON.

Half tone (for TIFF and BMP)

On(Gray) gives 16 grades of shading. ON(Color) gives 256 colors. There is no gradation if it is tuned OFF.

Comments

If a comment up to 25 characters in length is displayed beforehand in the upper left section of the screen, it is saved along with the waveform image.

Data compression (for TIFF and BMP)

For TIFF and BMP formats the data can be compressed using LZW and RLE, respectively.

However, compression is not possible when the half tone is OFF.

Auto naming function

When [Auto Naming] is turned ON, files with three digit numbers from 000 to 999 are automatically created. Specify the common name (maximum of five characters, specify at the File Name item) that is placed before the three digit number.

Note

- You cannot save screen image data while the measurement is in progress (START/STOP indicator is ON).
 - When saving the image data with the half tone set to OFF or saving to the Postscript format and the waveforms are overlapped, the color of the waveform on the screen temporarily changes during saving.
-

13.1 Initializing the Setup Information

≒For a functional description, see 1.8.≒

Procedure

1. Press the SHIFT+MARKER(INIT) key to display the Initialize menu.
2. Press the [Execute] soft key.

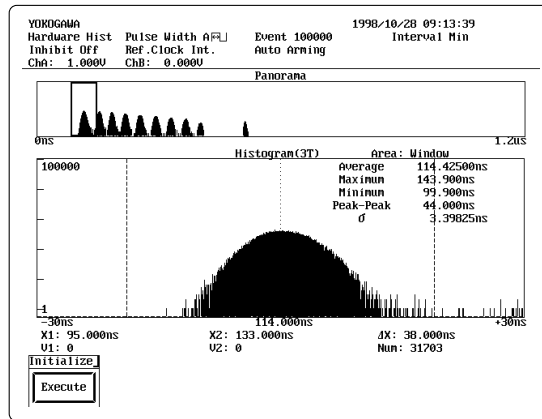

Initializing

3. An Alert!! menu is displayed. Turning the rotary knob to select [OK] and pressing the SELECT key executes the initialization.

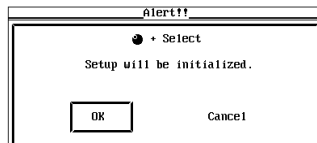

Canceling the initialization

3. An Alert!! menu is displayed. Turning the rotary knob to select [Cancel] and pressing the SELECT key cancels the initialization.

13.1 Initializing the Setup Information

Explanation

Initial settings

When the setup information is initialized, the parameters are reset to the following settings.

Item	Setting
MODE key	Hard Hist
FUNCTION key	
Function	Period
Channel/Slope	A↑ (Period)
	A ↑ B ↑ (TI)
	 (Pulse Width)
SAMPLE key	
Gate Mode	Event Gate
Event Num	100
Gate Time	1 μs
Gate Polarity	Positive
Sample Interval	0 μs
Arming	Auto
Ext Arm Slope	↑
Arming Delay	OFF
Delay Event	1
Delay Time	1 μs
Block	OFF
Block Size	1
Rest Mode	OFF
Rest Event	1
Rest Time	1 μs
Inhibit	OFF
Ref.Clock	Internal
INPUT key	
(CHA and CHB)	
Impedance	1 M
Coupling	DC
Trigger Mode	Manual
Manual Level	0V
Auto Level	50%
(EXT ARM/EXT GATE and INHIBIT)	
Impedance	1 M (fixed)
Coupling	DC (fixed)
Trigger Level	TTL

Items that cannot be initialized

The following items are not initialized. They are also not stored.

Item	Factory default settings
Setup information stored in the internal memory	Initial settings on page 13-2
Date/time	Date and time of shipment
Beep sound	ON
Click sound	ON
HDD Motor	ON
Brightness of the LCD monitor	4
Warning display	ON
Store/recall Number	0
SCSI device settings	
Own ID	6
HD ID	5
GP-IB settings	
Gpib Address	1
Endian	LSBFirst
Start Data	1
End Data	1
Data Type	Ascii
Data Select	Time Stamp
File	
File Item	Setup
Data Type	Ascii
Stat Item	Hist
Auto Naming	OFF
File Name	"TA520"
Comment	""
UTILITY key	
Function	Delete
Filter	All
FD Format	2HD 1.44 M
Format Type	Quick
Partition Num	1
Copy	
Copy to	Printer
Image	Copy
Image Format	TIFF
Half Tone	OFF (Black and white)
Compression	OFF
Calibration data	Values calibrated in standard operating conditions.

Note

- When initialization is executed, operations in progress such as measurement and calculation stop.
- To reset all the settings (reset to factory default), turn ON the power while pressing the RESET key. Note that when the power is turned ON while pressing the RESET key, the setup information stored in the internal memory is also reset.

13.2 Calibrating the Instrument

≡For a functional description, see 1.8.≡

Procedure

1. Press the UTILITY key to display the Utility menu.
2. Press the [Next] soft key to display the [Next 1/2] menu.
3. Press the [Calibration] soft key to display the Calibration menu.

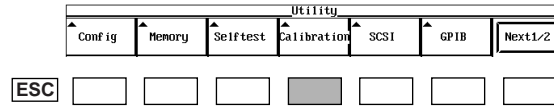

4. Press the [Exec] soft key.
The calibration results are listed.

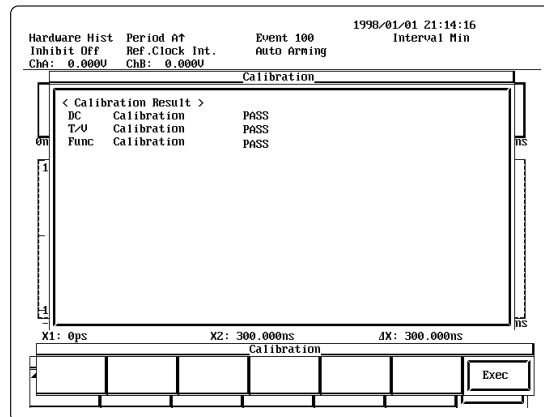

Explanation

Calibrated items

Using the internal calibration signal, the offset voltage of the input amplifier (DC Calibration), the conversion factor for the time/voltage converter (T/V Calibration), and the measurement function (Function Calibration) are automatically calibrated.

Executing the calibration

Execute calibration when the operating environment (temperature, humidity) of the instrument changes drastically.

When the power is turned OFF, the calibration data are reset to their factory default values (see page 13-3).

Calibration results

If the calibration is successful, [PASS] is displayed. If it is not, [FAIL] is displayed. If [FAIL] is displayed, do a self-test (see section 14.4) to inspect the instrument.

13.3 Outputting Monitor Signals

≒For a functional description, see 1.8.≒

Connection Procedure

Connect BNC cables to the monitor output terminals (for CHA and CHB) on the rear panel of the instrument.

Explanation

The signals corresponding to the input signal of CHA and CHB are output to the CHA and CHB monitor output terminals, respectively. However, how the monitor signal is output varies depending on the measurement function.

- Time interval measurement : Outputs the signals input to both CHA and CHB.
- Period/pulse width measurement : Outputs only the signals input to the selected channels.
- Output impedance : 50Ω (Typical value*)
- Output level : Approx. one fourth the amplitude of the input signal (within +/- 5 V) when the monitor device receives the signal with an input impedance of 50 Ω.

* Typical values represent typical or average values. They are not strictly guaranteed.



CAUTION

Do not externally apply voltage to the monitor output terminals. It can damage the instrument.

13.4 Checking the Setup Conditions of the Instrument and the ROM Version

Procedure

1. Press the UTILITY key to display the Utility menu.
2. Press the [Next] soft key to display the [Next 2/2] menu.

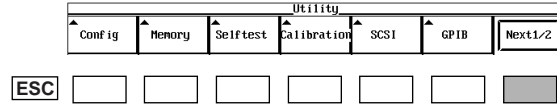

Checking the setup conditions of the instrument

3. Pressing the [Setup Info] soft key displays the Setup Information menu. You can scroll the list by turning the rotary knob.

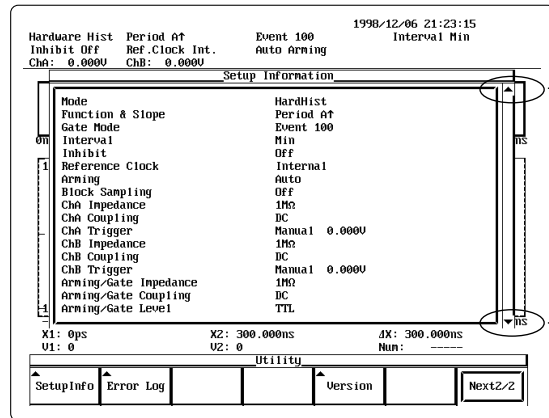

Use the rotary knob to scroll through the list



Checking the ROM version

3. Pressing the [Version] soft key displays the Version Information menu.

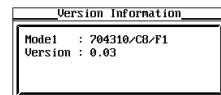

Explanation

Setup Conditions that are displayed

The measurement conditions and display parameters set with the following keys can be displayed.

MODE key, FUNCTION key, INPUT key, DISPLAY key, SCALE key, MARKER key, UTILITY key

ROM version

The model name and suffix code of the instrument and the software version can be displayed.

13.5 Turning ON/OFF the Click Sound, Beep Sound, and Warning Display, Setting the Brightness of the LCD Monitor

Procedure

1. Press the UTILITY key to display the Utility menu.
2. Press the [Next] soft key to display the [Next 1/2] menu.
3. Press the [Config] soft key to display the Configuration menu.

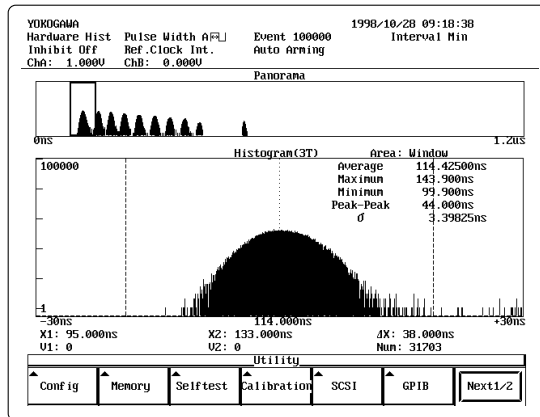

Turn ON/OFF the beep sound

4. Press the [Beep] soft key to select [ON] or [OFF].

Turn ON/OFF the click sound

4. Press the [Click Sound] soft key to select [ON] or [OFF].

Setting the brightness of the LCD monitor

4. Press the [LCDBright] soft key.
 Turn the rotary knob to set the brightness.

Turning ON/OFF the warning display

4. Press the [Warning] soft key to select [ON] or [OFF].

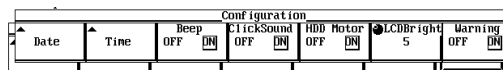

13.5 Turning ON/OFF the Click Sound, Beep Sound, and Warning Display, Setting the Brightness of the LCD Monitor

Explanation

Turning ON/OFF the beep sound

You can set whether or not to sound a beep when a warning message is displayed on the screen. The default setting is ON.

Turning ON/OFF the click sound

You can select whether or not to sound clicks when turning the rotary knob. The default setting is ON.

Setting the brightness of the LCD monitor

The brightness of the LCD monitor can be adjusted. The darkest setting is [0] and the brightest setting is [7].

Turning ON/OFF the warning display

You can set whether or not to display warning messages. The default setting is ON.

Note

- Even if the warning display is turned OFF, the warning message is recorded to the error log if a warning occurs.
 - Regardless of its ON/OFF setting, clicks no longer sound, if the beep sound is turned OFF.
-

14.1 Troubleshooting

For corrective actions when a message appears on the screen, see section 14.2 “Messages.”

If servicing is required or if the instrument does not operate properly after taking the following corrective actions, contact your nearest YOKOGAWA dealer.

Problem	Possible Cause	Corrective Action	Reference Sections
The power does not turn ON.	The source voltage is outside of the allowed range.	Use a proper voltage source.	3.3
	The fuse is blown.	Check for the cause, and if there is no problem replace it with a new fuse.	14.7
Nothing is displayed.	The screen brightness is set extremely dark.	Adjust the brightness of the LCD monitor.	13.5
	The screen is extremely cold.	The ambient temperature should be 5°C or higher.	–
The display is odd.	The system is not operating properly.	Reboot the instrument.	–
Keys do not operate.	The instrument is in remote mode.	Set it to local mode.	*
Cannot make measurements.	Incorrect trigger level.	Set a proper trigger level.	6.6
	Measurement channel is not selected.	Check the channel.	5.2 to 5.4
	Exceeding measurement range.	Check the measurement range.	5.2 to 5.4
	Incorrect arming setting.	Check the arming setting.	6.4
	Incorrect inhibit setting.	Check the inhibit setting.	6.5
Cannot save to the specified medium	Incorrect reference signal.	Check the reference signal.	6.7
	The medium is not formatted.	Format the medium.	11.5
	The medium is not properly inserted.	Insert the medium properly.	11.1
	The medium is write-protected.	Remove the write-protection.	–
	Insufficient space on the medium.	Delete unneeded files or use another medium.	11.9
	Attempted to save while the measurement is in progress.	Save after the measurement completes or stop the measurement.	–
Cannot load from the specified medium	The medium is not properly inserted.	Insert the medium properly.	11.1
	Attempted to load while the measurement is in progress.	Load after the measurement completes or stop the measurement.	11.6, 11.7, 11.8
 is blinking in the top right corner of the screen.	The lithium battery is dead. The system is not operating properly.	Do a self-test.	14.4
Cannot print to the built-in printer.	The paper roll is not installed.	Install the roll of paper.	12.1
	The position of the release arm is not correct.	Move the release arm to the [HOLD] position.	12.1
	The printer head is damaged or has worn out.	Servicing is necessary.	–
	Attempted to print while the measurement is in progress.	Print after the measurement completes or stop the measurement.	12.2, 12.3
A medium cannot be recognized.	The cable is not connected.	Connect the cable.	11.3
	Incorrect SCSI ID number.	Set a correct ID number.	11.4
	Incorrect format.	Format the medium.	11.5
	Medium is damaged.	–	–
Cannot control via the GP-IB interface.	The GP-IB address is not correct.	Use the correct address.	*
	Using the interface in a way that does not comply with the electrical and mechanical specifications (IEEE St'd 488-1978).		

* See the GP-IB Interface User's Manual (IM704310-12E)

14.2 Messages

The following three types of messages can appear in the center of the screen.

- Error messages
Displayed when an invalid operation is attempted or when the instrument is behaving abnormally.
- Warning messages
Displayed when the instrument is in a state in which the user needs to be warned (for example when the measurement data overflows).
- Alert messages
Displayed in cases such as before formatting a disk.

This section describes the meanings of the error messages (except for communication related error messages) and warning messages.

For communication related error messages (100 to 299, 400 to 499, 912 to 915) see the GP-IB Interface User's Manual (IM704310-12E).

Execution Errors(600 to 799)

Code	Message	Description	Page
601	Invalid path name or SCSI ID.	The path name or the SCSI ID is not correct.	11-4, 11-11
602	No floppy disk inserted.	No floppy disk is inserted in the floppy disk drive.	11-1
603	No SCSI device.	The SCSI device could not be detected.	11-3
604	Media failure.	The medium is abnormal.	–
605	File not found.	The specified file does not exist.	Chapter 11
606	Media is protected.	The medium is write-protected.	–
607	Media was removed while accessing.	The medium was removed while it was being accessed.	–
609	File already exists.	A file with the same name already exists.	–
610	Contains invalid characters.	Invalid characters are being used.	4-3
611, 612	Media full.	There is not enough free space on the medium.	11-11, 11-14, 11-17
613	Directory is not empty.	The directory is not empty.	11-20
614	File is protected.	The file is set to read-only.	11-20, 11-23
615	Physical format error.	The medium could not be physically formatted.	11-7
616-620	File system failure.	The file system is abnormal.	–
621	File is damaged.	The file is damaged	–
622 to 641	File system failure.	The file system is abnormal	–
642	No media exists in SCSI device.	There is no medium in the SCSI device	–
646 to 654	Media failure.	The medium is abnormal	–
656 to 663	File system failure.	The file system is abnormal	–
657, 665	Cannot load this file format.	The file was saved on another device. The file cannot be loaded.	–
666	File is now being accessed. Wait a moment.	The file is being accessed. Wait until it finishes.	–
668	Cannot find .HDR file.	There is no .HDR file.	11-14
671	Stop measurement before accessing file.	The file cannot be accessed while the measurement is in progress.	11-11, 11-15, 11-17
672	Data to be saved do not exist.	There are no data to be saved.	–
673	SCSI controller failure.	The SCSI controller is abnormal.	–
680	Illegal printer head position.	Move the release arm to the [HOLD] position	12-3
681	Paper empty.	The paper roll is empty	12-2
682	Printer over heat.	The printer has overheated	–
683	Printer too cool.	The printer temperature is abnormal.	–
685	Printer time out.	The printer temperature is abnormal.	–
686	Printer circuit failure.	The printer circuit has malfunctioned	–
687	Printer aborted.	Printer operation has been aborted.	–

Code	Message	Description	Page
701	Stop measurement before using internal printer.	Obtaining a hard copy is not possible while the measurement is in progress.	12-5
708	Cannot output data while measuring.	The data cannot be output while the measurement is in progress.	12-8
710	Internal printer in use. Wait a moment.	A hard copy is in progress. Wait until it finishes.	–
711	Image data failure.	The image data are not correct.	–
712	Cannot compress this image.	This screen image cannot be compressed.	–

Setting Errors (800 to 899)

Code	Message	Description	Page
800	Incorrect date-time.	The set date and time are not correct.	3-10
801	Illegal file name.	The file name is not correct	4-3
802	Cannot use identical SCSI ID.	Found duplicate SCSI IDs	11-4
810	Cannot change window-mode	The window mode cannot be changed while performing inter-symbolic interference analysis.	9-2
811	Setting incomplete to use ISI. Set polarity to Both in Pulse Width function.	Inter-symbolic interference analysis cannot be used with the current settings. Set the polarity to Both in the pulse width measurement.	9-2

System Error (900 and higher)

Code	Message	Description	Page
906	Fan stopped. Turn OFF the power immediately.	The cooling fan has stopped. Turn OFF the power immediately.	–
908	Inside temperature is too high.	The temperature inside the instrument is too high.	–
912	Fatal error in Communication-driver.	Communication driver error.	–
914	A communication time-out has occurred.	Communication time-out error.	–
918	Turn ON the internal hard disk motor.	Turn ON the internal hard disk motor.	11-2

Warning (0 to 99)

Code	Message	Description	Page
50	Sample number overflow.	The maximum number of samples that can be measured has been exceeded.	15-1
51	Time stamp data overflow.	The time stamp data have exceeded the longest sampling period.	1-4, 15-1
52	Measurement data overflow.	The measured data have exceeded the measurement range.	15-2, 15-3
53	Measured T failure.	Failed to measure the value of T for the auto window.	15-6
54	Estimated T failure.	Failed to estimate the value of T for the auto	15-6
55	Rest time is too short.	The pause time is too short.	6-6

Warning Mark

The following warning mark is displayed at the top of the screen when there is an error message or warning message.

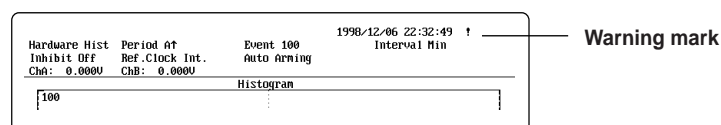

When you see a warning mark, the error and warning messages can be listed by pressing the [Error Log] soft key of the UTILITY key to display the error log. If there are many messages that they do not fit in the window, the rotary knob can be turned to scroll through the list. For details related to the procedures, see section 14.3.

14.3 Using the Error Logging Function

Procedure

1. Press the UTILITY key to display the Utility menu.
2. Press the [Next] soft key to display the [Next2/2] menu.

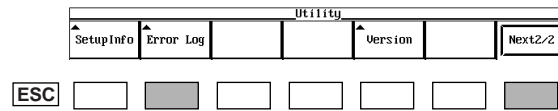

Displaying the error log

3. Press the [Error Log] soft key to display the error log.
If there are many messages and they do not fit in the window, the rotary knob can be turned to scroll through the messages.
4. Pressing the [Clear] soft key clears the messages and the ! mark disappears.

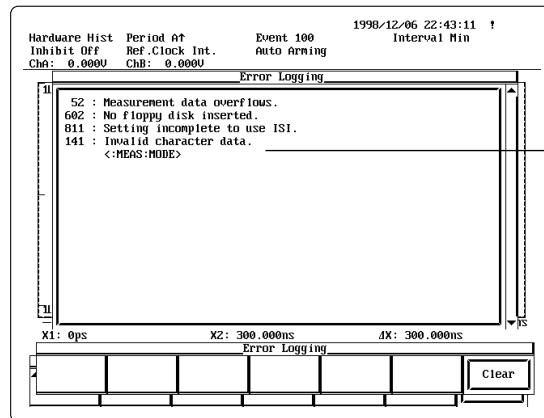

Error and the command that caused the error



Explanation

When an operation error, a communication error, or a warning occurs, the instrument creates an error message list and displays a ! mark in the top right corner of the screen. The details of the message can be checked by displaying the error log. The ! mark remains on the screen until you press the [Clear] soft key in the [Error Logging] menu to clear the message list.

Note

Warning messages cannot be cleared using the [Clear] key. The message will automatically disappear when the problem is resolved such as by restarting the measurement.

14.4 Performing a Self-test

Procedure

1. Press the UTILITY key to display the Utility menu.
2. Press the [Next] soft key to display the [Next1/2] menu.
3. Press the [Selftest] soft key to display the Self-test menu.

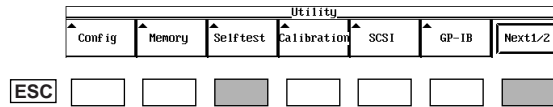

Testing the panel

4. Press the [Selftest] soft key to display the test item selection menu.

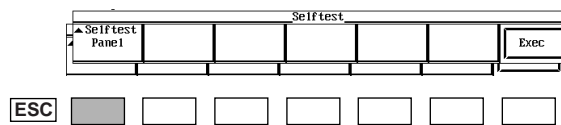

5. Press the [Panel] soft key.
6. Pressing the [Exec] soft key starts the panel test.

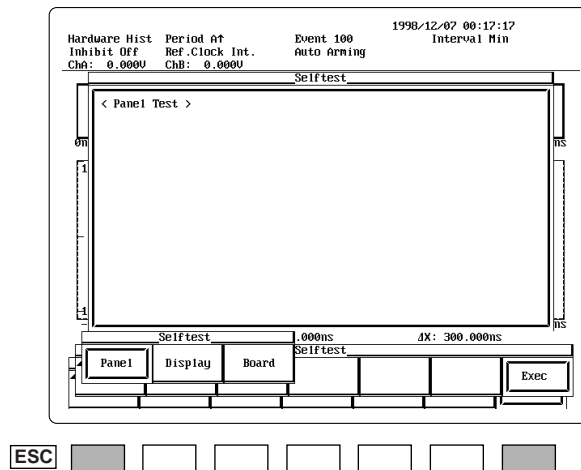

7. Press each key and check that the corresponding key name is displayed on the screen.
8. Turn the rotary knob to the left and right and check that the correct direction is displayed on the screen.
9. Press the ESC key twice to return to the self-test menu.

Testing the display

4. Press the [Selftest] soft key to display the test item selection menu.

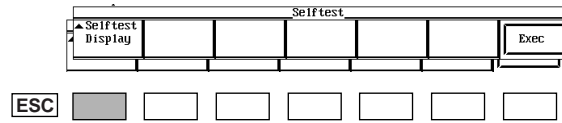

5. Press the [Display] soft key.
6. Pressing the [Exec] soft key starts the display test.

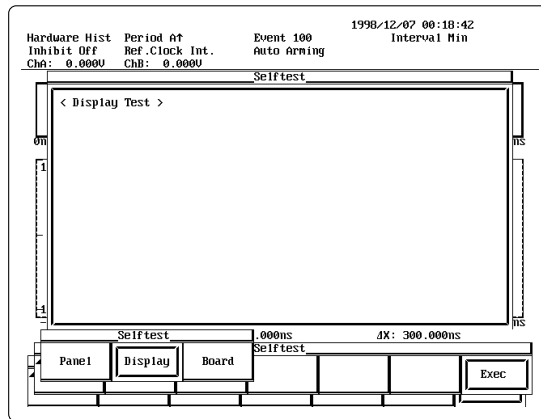

7. Use the arrow keys to alternately display the test item and test information and check that there are no black spots or other abnormalities on the screen.
8. Turn the rotary knob to check that the brightness of the LCD monitor changes.
9. Press the ESC key to return to the self-test menu.

Testing the board

4. Press the [Selftest] soft key to display the test item selection menu.

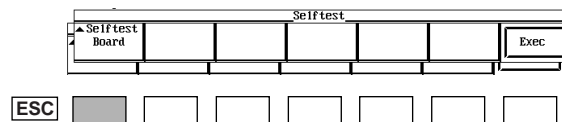

5. Press the [Board] soft key.
6. Pressing the [Exec] soft key starts the board test and the results are displayed. If PASS is not displayed for each test item, the instrument is malfunctioning.

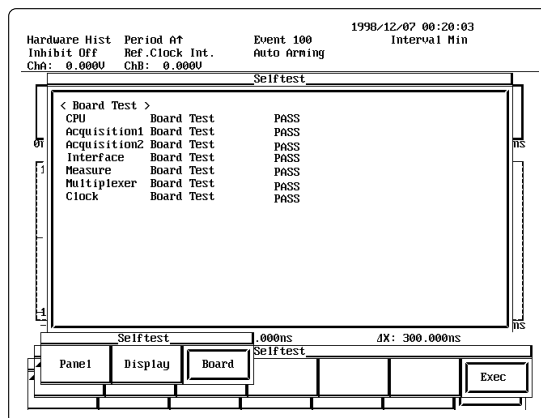

Explanation

Remove all cables that are connected to the terminals on the front and rear panels and stop the measurement.

If abnormalities are found on a test item

The instrument probably has malfunctioned. Contact your nearest YOKOGAWA dealer.

Board test messages

The following messages may appear. If any of these messages appears, servicing is necessary. Contact your nearest YOKOGAWA dealer.

- Low Battery : The battery has died. It must be replaced.
- Calibration Data Lost : The internal calibration values may have been lost. Re-calibration is necessary.
- ROM Error/DRAM Error : Abnormality may have occurred in the internal memory.
/SRAM Error

14.5 Adjusting the Time Base



CAUTION

- Do not apply a voltage exceeding the maximum input voltage to the input terminals. It can damage the input section.
- Do not apply an external voltage to the output terminals. It can damage the internal circuit.

Instruments required

Prepare the following instruments.

Standard frequency generator

- Frequency accuracy : 0.25 ppm or better
- Recommended instrument: 5071A (by HP) or 9500/EN100

Frequency counter

- Frequency resolution : 1 Hz or better
- Recommended instrument: TA1100 Time Interval Analyzer (by YOKOGAWA)

The procedures for adjusting the time base (reference clock) using the recommended instruments are provided below.

Connecting the instruments

- Check that all the instruments are turned OFF, then connect the instruments.
- Connect the output of the standard frequency generator to the REFERENCE IN (rear panel) terminal of the frequency counter (TA1100) and measure using the external reference frequency.
- Connect the REFERENCE OUT (rear panel) terminal of the TA520 to the CHA terminal of the frequency counter (TA1100).

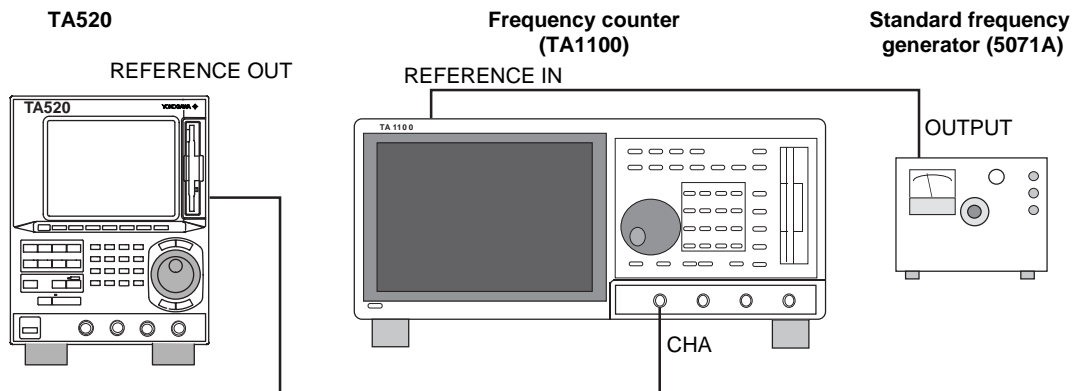

Instrument settings

TA520 : None

TA1100 :

- Function : Frequency A
- Gate time : 1 ms
- Sampling size : 1
- Sampling mode : FREE
- Display : NUMERIC
- Input setting CHA : DC coupling, ATT=OFF, 50 W, trigger level = 0 V
- REFERENCE : EXTERNAL

5071A : None

Adjustment procedure

Adjust the TA520 after a warm-up time of 30 minutes.

Turn the REFERENCE ADJUST on the rear panel of the TA520, and adjust it so that the read-out value of the frequency counter is within the following range.

9.999990 MHz to 10.000010 MHz (10 MHz \pm 10 Hz, within \pm 1 ppm)

14.6 Executing the Performance Test



CAUTION

- Do not apply a voltage exceeding the maximum input voltage to the input terminals. It can damage the input section.
- Do not apply an external voltage to the output terminals. It can damage the internal circuit.

Testing the Trigger Voltage Accuracy

Instruments required

Prepare the following instruments.

DC voltage generator

- Voltage accuracy : 1 mV or better
- Recommended instrument : Programmable DC voltage/current source 7651 (by YOKOGAWA)

The procedures for testing the trigger voltage accuracy using the recommended instruments are provided below.

Connecting the instruments

- Check that all the instruments are turned OFF, then connect the instruments.
- Connect the output of the DC voltage generator to the input terminal (CHA or CHB) of the TA520.

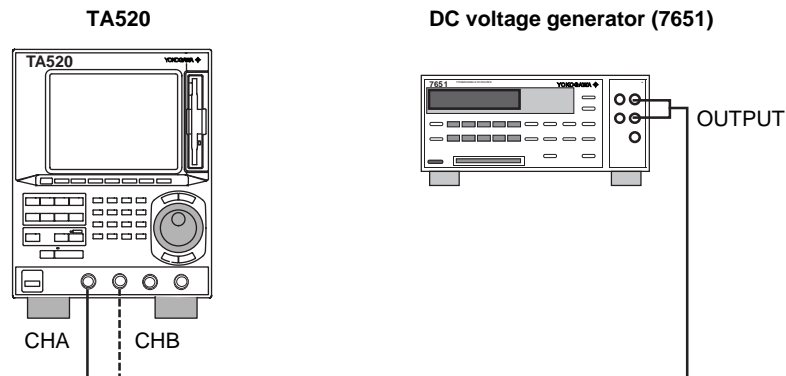

Instrument settings

- TA520 : Input settings : DC coupling, 1 M Ω , trigger level = 0 V
- 7651: Output level : 4.000 V
: 2.000 V
: 0 V
: -2.000 V
: -4.000 V

Note

If there is noise due to the environment, attach a 1 μ F capacitor between the signal cable and ground.

Test method

- Test the TA520 after a warm-up time of 30 minutes.
- This test checks the error in the trigger levels by comparing the input DC voltage to the trigger level set on the TA520.
- The input indicator of the TA520 is monitored to detect the actual trigger levels.

Test procedure

1. Connect the output of the 7651 to CHA of the TA520.
2. Set the output level of the 7651 to 4.000 V.
3. Set the trigger level of the TA520 to 4.100 V.
4. Start the measurement on the TA520.
5. Decrease the trigger level of the TA520 by 5 mV steps. When the input indicator lights up, record the trigger level as VL.
6. Set the trigger level of the TA520 to 3.900 V.
7. Increase the trigger level of the TA520 by 5 mV steps. When the input indicator lights up, record the trigger level as VH.
8. Calculate the mean value of VL and VH and check that the value is within the allowable range.
 $VTRIG=(VL+VH)/2$
9. Set the output of the DC voltage generator to 2.000 V, 0 V, -2.000 V, and -4.000 V and repeat the same test.
10. Repeat steps 1 through 9 for CHB.

Test results

CHA

Voltage of 7651	VL	VH	VTRIG	Allowable Range
4.000 V				3.950 V to 4.050 V
2.000 V				1.970 V to 2.030 V
0.000 V				-0.010 V to 0.010 V
-2.000 V				-2.030 V to -1.970 V
-4.000 V				-4.050 V to -3.950 V

CHB

Voltage of 7651	VL	VH	VTRIG	Allowable Range
4.000 V				3.950 V to 4.050 V
2.000 V				1.970 V to 2.030 V
0.000 V				-0.010 V to 0.010 V
-2.000 V				-2.030 V to -1.970 V
-4.000 V				-4.050 V to -3.950 V

Testing the Input Sensitivity

Instruments required

Prepare the following instruments.

Synthesized signal generator

- Frequency range : 10 MHz to 50 MHz or higher
- Output level : 720 mVrms or higher
- Output level accuracy : ± 0.1 dB or better
- Recommended instrument : 8657B synthesized signal generator (by HP)

The procedures for testing the input sensitivity using the recommended instruments are provided below.

Connecting the instruments

- Check that all the instruments are turned OFF, then connect the instruments.
- Connect the output of the synthesized signal generator to the input terminal (CHA or CHB) of the TA520.

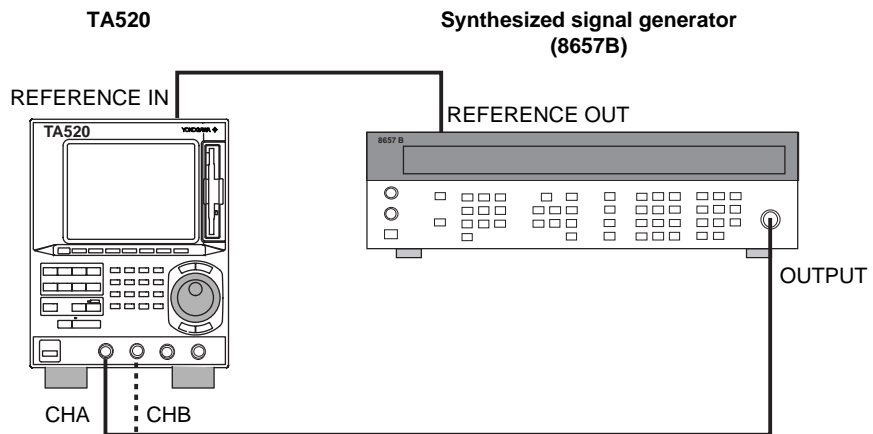

Instrument settings

TA520:

- Sampling mode : Hardware histogram mode
- Input settings : DC coupling, 50 Ω (both CHA and CHB), trigger level = 0 V
- Function : Period A, B
- Gate : Event, 1000000
- Reference : External
- X Center, X Span :

Input Frequency	X Center	X Span
10 MHz	100 ns	15 ns
20 MHz	50 ns	15 ns
40 MHz	25 ns	15 ns

- Y High : 10^6

8657B:

- Frequency : 10 MHz
 : 20 MHz
 : 40 MHz
- Level : 35 mVrms

Test method

- Test the TA520 after a warm-up time of 30 minutes.
- Set the frequency of the 8657B to the values given in the table below, and check that the measured values (mean value and standard deviation) are within the allowable range using the period measurement function on the TA520. Perform the same test on both CHA and CHB.

Test results

CHA↑

Frequency (8657B)	Mean Value		Standard Deviation	
	Measured Value	Allowable Range	Measured Value	Allowable Range
10 MHz		99.7 ns to 100.3 ns		280 ps or less
20 MHz		49.7 ns to 50.3 ns		190 ps or less
40 MHz		24.7 ns to 25.3 ns		140 ps or less

CHA↓

Frequency (8657B)	Mean Value		Standard Deviation	
	Measured Value	Allowable Range	Measured Value	Allowable Range
10 MHz		99.7 ns to 100.3 ns		280 ps or less
20 MHz		49.7 ns to 50.3 ns		190 ps or less
40 MHz		24.7 ns to 25.3 ns		140 ps or less

CHB↑

Frequency (8657B)	Mean Value		Standard Deviation	
	Measured Value	Allowable Range	Measured Value	Allowable Range
10 MHz		99.7 ns to 100.3 ns		280 ps or less
20 MHz		49.7 ns to 50.3 ns		190 ps or less
40 MHz		24.7 ns to 25.3 ns		140 ps or less

CHB↓

Frequency (8657B)	Mean Value		Standard Deviation	
	Measured Value	Allowable Range	Measured Value	Allowable Range
10 MHz		99.7 ns to 100.3 ns		280 ps or less
20 MHz		49.7 ns to 50.3 ns		190 ps or less
40 MHz		24.7 ns to 25.3 ns		140 ps or less

Testing the Frequency Resolution and the Minimum Measured Value

Instruments required

Prepare the following instruments.

Synthesized signal generator

- Frequency range : 10 MHz to 50 MHz or higher
- Output level : 720 mVrms or higher
- Output level accuracy : ± 0.1 dB or better
- Recommended instrument : 8657B synthesized signal generator (by HP)

The procedures for testing the frequency resolution and minimum measured value using the recommended instruments are provided below.

Connecting the instruments

- Check that all the instruments are turned OFF, then connect the instruments.
- Connect the output of the synthesized signal generator to the input terminal (CHA or CHB) of the TA520.

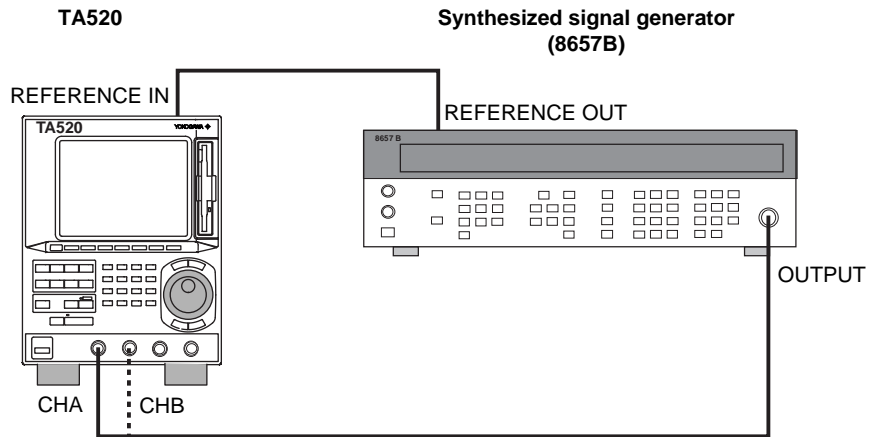

Instrument settings

TA520:

- Sampling mode : Hardware histogram mode
- Input settings : DC coupling, 50 Ω (both CHA and CHB), trigger level = 0 V
- Function : Period A, B
- Gate : Event, 1000000
- Reference : External
- X Center, X Span :

Input Frequency	X Center	X Span
10 MHz	100 ns	15 ns
20 MHz	50 ns	15 ns
40 MHz	25 ns	15 ns
50 MHz	20 ns	15 ns
126 MHz	8 ns	15 ns

- Y High : 10^6

8657B:

- Frequency : 10 MHz
 : 20 MHz
 : 40 MHz
 : 50 MHz
 : 126 MHz
- Level : 360 mVrms

Test method

- Test the TA520 after a warm-up time of 30 minutes.
- Set the frequency of the 8657B to the values given in the table below, and check that the measured values (mean value and standard deviation) are within the allowable range using the period measurement function on the TA520. Perform the same test on both CHA and CHB.

Test results

CHA↑

Frequency (8657B)	Mean Value		Standard Deviation	
	Measured Value	Allowable Range	Measured Value	Allowable Range
10 MHz		99.7 ns to 100.3 ns		120 ps or less
20 MHz		49.7 ns to 50.3 ns		110 ps or less
40 MHz		24.7 ns to 25.3 ns		100 ps or less
50 MHz		19.7 ns to 20.3 ns		100 ps or less
126 MHz		7.63 ns to 8.23 ns		100 ps or less

CHA↓

Frequency (8657B)	Mean Value		Standard Deviation	
	Measured Value	Allowable Range	Measured Value	Allowable Range
10 MHz		99.7 ns to 100.3 ns		120 ps or less
20 MHz		49.7 ns to 50.3 ns		110 ps or less
40 MHz		24.7 ns to 25.3 ns		100 ps or less
50 MHz		19.7 ns to 20.3 ns		100 ps or less
126 MHz		7.63 ns to 8.23 ns		100 ps or less

CHB↑

Frequency (8657B)	Mean Value		Standard Deviation	
	Measured Value	Allowable Range	Measured Value	Allowable Range
10 MHz		99.7 ns to 100.3 ns		120 ps or less
20 MHz		49.7 ns to 50.3 ns		110 ps or less
40 MHz		24.7 ns to 25.3 ns		100 ps or less
50 MHz		19.7 ns to 20.3 ns		100 ps or less
126 MHz		7.63 ns to 8.23 ns		100 ps or less

CHB↓

Frequency (8657B)	Mean Value		Standard Deviation	
	Measured Value	Allowable Range	Measured Value	Allowable Range
10 MHz		99.7 ns to 100.3 ns		120 ps or less
20 MHz		49.7 ns to 50.3 ns		110 ps or less
40 MHz		24.7 ns to 25.3 ns		100 ps or less
50 MHz		19.7 ns to 20.3 ns		100 ps or less
126 MHz		7.63 ns to 8.23 ns		100 ps or less

Testing the Pulse Width Resolution

Instruments required

Prepare the following instruments.

Synthesized signal generator

- Frequency range : 10 MHz to 50 MHz or higher
- Output level : 720 mVrms or higher
- Output level accuracy : ± 0.1 dB or better
- Recommended instrument : 8657B synthesized signal generator (by HP)

The procedures for testing the pulse width resolution using the recommended instruments are provided below.

Connecting the instruments

- Check that all the instruments are turned OFF, then connect the instruments.
- Connect the output of the synthesized signal generator to the input terminal (CHA or CHB) of the TA520.

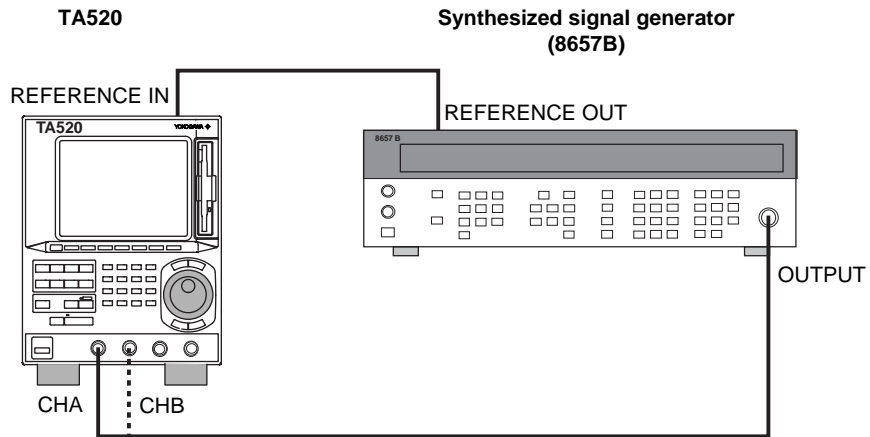

Instrument settings

TA520:

- Sampling mode : Hardware histogram mode
- Input settings : DC coupling, 50 Ω (both CHA and CHB), trigger level = 0 V
- Function : Pulse width A, B
- Gate : Event, 1000000
- Reference : External
- X Center, X Span :

Input Frequency	X Center	X Span
10 MHz	50 ns	15 ns
20 MHz	25 ns	15 ns

- Y High : 10^6

8657B:

- Frequency : 10 MHz
 : 20 MHz
- Level : 360 mVrms

Test method

- Test the TA520 after a warm-up time of 30 minutes.
- Set the frequency of the 8657B to the values given in the table below, and check that the measured values (mean value and standard deviation) are within the allowable range using the pulse width measurement function on the TA520. Perform the same test on both CHA and CHB.

Test resultsCHA 

Frequency (8657B)	Mean Value		Standard Deviation	
	Measured Value	Allowable Range	Measured Value	Allowable Range
10 MHz		48.4 ns to 51.6 ns		120 ps or less
20 MHz		23.7 ns to 26.3 ns		110 ps or less

CHA 

Frequency (8657B)	Mean Value		Standard Deviation	
	Measured Value	Allowable Range	Measured Value	Allowable Range
10 MHz		48.4 ns to 51.6 ns		120 ps or less
20 MHz		23.7 ns to 26.3 ns		110 ps or less

CHB 

Frequency (8657B)	Mean Value		Standard Deviation	
	Measured Value	Allowable Range	Measured Value	Allowable Range
10 MHz		48.4 ns to 51.6 ns		120 ps or less
20 MHz		23.7 ns to 26.3 ns		110 ps or less

CHB 

Frequency (8657B)	Mean Value		Standard Deviation	
	Measured Value	Allowable Range	Measured Value	Allowable Range
10 MHz		48.4 ns to 51.6 ns		120 ps or less
20 MHz		23.7 ns to 26.3 ns		110 ps or less

Testing the A-to-B Interval Resolution

Instruments required

Prepare the following instruments.

Synthesized signal generator

- Frequency range : 10 MHz to 50 MHz or higher
- Output level : 720 mVrms or higher
- Output level accuracy : ± 0.1 dB or better
- Recommended instrument : 8657B synthesized signal generator (by HP)

Power divider

- Characteristic impedance : 50 Ω
- Recommended instrument : 700966 Power divider (by YOKOGAWA)

The procedures for testing the A-to-B interval resolution using the recommended instruments are provided below.

Connecting the instruments

- Check that all the instruments are turned OFF, then connect the instruments.
- Connect the output of the synthesized signal generator to the input terminal (CHA or CHB) of the TA520 via the power divider.
- Use coaxial cables having identical lengths for the connection from the power divider to the two input terminals (CHA and CHB) of the TA520.

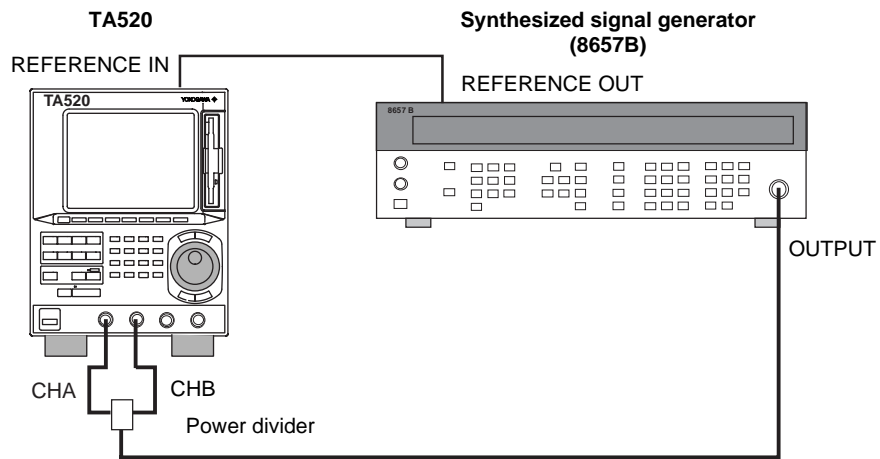

Instrument settings

TA520:

- Sampling mode : Hardware histogram mode
- Input settings : DC coupling, 50 Ω (both CHA and CHB), trigger level = 0 V
- Function : A to B interval
- Gate : Event, 1000000
- Reference : External
- X Center, X Span :
- When **A ↑ B ↑** or **A ↓ B ↓**

Input Frequency	X Center	X Span
10 MHz	0 ns	15 ns
20 MHz	0 ns	15 ns

- When **A ↑ B ↓** or **A ↓ B ↑**

Input Frequency	X Center	X Span
10 MHz	50 ns	15 ns
20 MHz	25 ns	15 ns

- Y High : 10^6

8657B:

- Frequency : 10 MHz
 : 20 MHz
- Level : 720 mVrms

Test method

- Test the TA520 after a warm-up time of 30 minutes.
- Set the frequency of the 8657B to the values given in the table below, and check that the measured values (mean value and standard deviation) are within the allowable range using the time interval measurement function on the TA520. Perform the same test on both CHA and CHB.

Test results**A ↑ B ↓**

Frequency (8657B)	Mean Value		Standard Deviation	
	Measured Value	Allowable Range	Measured Value	Allowable Range
10 MHz		-1 ns to 1.6 ns		120 ps or less
20 MHz		-1 ns to 1.3 ns		110 ps or less

A ↓ B ↓

Frequency (8657B)	Mean Value		Standard Deviation	
	Measured Value	Allowable Range	Measured Value	Allowable Range
10 MHz		-1 ns to 1.6 ns		120 ps or less
20 MHz		-1 ns to 1.3 ns		110 ps or less

A ↑ B ↓

Frequency (8657B)	Mean Value		Standard Deviation	
	Measured Value	Allowable Range	Measured Value	Allowable Range
10 MHz		48.4 ns to 51.6 ns		120 ps or less
20 MHz		23.7 ns to 26.3 ns		110 ps or less

A ↓ B ↑

Frequency (8657B)	Mean Value		Standard Deviation	
	Measured Value	Allowable Range	Measured Value	Allowable Range
10 MHz		48.4 ns to 51.6 ns		120 ps or less
20 MHz		23.7 ns to 26.3 ns		110 ps or less

14.7 Replacing the Power Fuse



WARNING

- To avoid fire, use only a fuse having the specified rating (voltage, current, and type)
Make sure to turn OFF the instrument and unplug the power cord before replacing the fuse.
- Never short the fuse holder.

Specified Rating

The power fuse used on this instrument is specified as follows.

Maximum rated voltage: 250 V

Maximum rated current: 3 A

Type : Time lag

Standard : UL/CSA certified

Part number : A1436EF

Replacement Procedures

Follow the procedures below to replace the power fuse.

1. Turn OFF the power switch.
2. Unplug the power cord from the power outlet.
3. Place the tip of a Philips screwdriver in the dented section of the fuse holder on the power connector side and move the driver in the direction of the arrow to remove the fuse holder.
4. Take out the shortened fuse that is attached to the tip of the fuse holder.
5. Attach a new fuse to the holder and then place the fuse holder back in its original position.

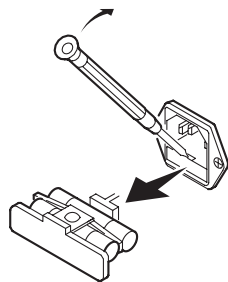

Note

The user cannot replace the fuse that is located inside the case. If you believe the fuse inside the case is blown, contact your nearest YOKOGAWA dealer as listed on the back cover of this manual.

The ratings of the fuse that is used inside the case are shown below.

Location	Maximum Rated Voltage	Maximum Rated Current	Type	Standard
Inlet	250 V	3 A	Time lag	UL/CSA certified
CPU board	250 V	800 mA	Time lag	VDE/SEMKO certified

14.8 Recommended Replacement Parts

The one-year warranty applies only to the main unit of the instrument (starting from the day of delivery) and does not cover any other items nor expendable items (items which wear out). The replacement period for expendable items varies depending on the conditions of use. Refer to the table below as a general guideline. Contact your nearest YOKOGAWA dealer for replacement parts.

Part Name	Recommended Replacement Period
Built-in printer	Under normal usage, 120 rolls of paper
LCD backlight	3 years
Internal hard disk	One year after purchase (data on the disk are not covered)
Cooling fan (front)	3 years
Cooling fan (rear)	3 years
Backup battery (Lithium battery)	3 years

15.1 Measurement Input and Trigger









Item	Specification
Number of input channels	2 (CHA, CHB)
Input coupling	DC/AC
Input connector	BNC connector
Input impedance	50 Ω /1 M Ω , 20 pF (Typical value* ¹)
Frequency characteristics (-3 dB point)	<ul style="list-style-type: none"> When the input coupling is DC: DC to 200 MHz (Typical value*¹) When the input coupling is AC and <ul style="list-style-type: none"> the input impedance is 50 Ω: 680 kHz to 200 MHz (Typical value*¹) the input impedance is 1 MΩ: 35 Hz to 200 MHz (Typical value*¹)
Internal jitter	100 ps rms
Minimum input pulse width	3 ns
Operating voltage range	-5 V to 5 V
Maximum input voltage	<ul style="list-style-type: none"> When the input impedance is 50 Ω: 5 Vrms When the input impedance is 1 MΩ and <ul style="list-style-type: none"> DC<input frequency=""/>≤100 kHz: 40 V (DC+ACpeak) 100kHz<input frequency=""/>≤100 MHz: {3.5/f+5}V(DC+ACpeak), where f is frequency in units of MHz Over voltage category: I and II
Input sensitivity* ²	100 mVp-p
Input amplifier noise	400 μ Vrms (Typical value* ¹)
Trigger	<ul style="list-style-type: none"> Trigger mode: Select from single auto trigger, repeat auto trigger, and manual trigger Trigger level (during manual trigger) <ul style="list-style-type: none"> Range: -5 V to 5 V (Selectable using panel operation during manual trigger) Accuracy*²: $\pm(10 \text{ mV} + 1\% \text{ of specified value})$ Resolution: 1 mV Trigger level (during single auto trigger and repeat auto trigger) <ul style="list-style-type: none"> Range: 0% to 100% Resolution: 1% Input signal conditions during single auto trigger and repeat auto trigger: Continuous signal between 1 kHz and 50 MHz Time to set the single auto trigger and repeat auto trigger: 0.7 s (Typical value*¹)
Sampling	<ul style="list-style-type: none"> Sampling mode: Select time stamp mode or hardware histogram mode Maximum sampling rate <ul style="list-style-type: none"> 43 MS/s continuous sampling (approx. 23 ns intervals) Maximum sampling size (Maximum number of data points) <ul style="list-style-type: none"> During time stamp mode: 512,000 During hardware histogram mode: 10⁹ Sampling interval <ul style="list-style-type: none"> 0 μs, 1 μs to 1s (Resolution: 1 μs) If 0 μs is selected, the sampling interval is set to the interval of the maximum sampling rate (approx. 23 ns). Select only during the time stamp mode. Longest sampling period <ul style="list-style-type: none"> When the sampling interval is set to 0 μs: <ul style="list-style-type: none"> 320 s (Time after arming) When the sampling interval is other than 0 μs or when the mode is set to hardware histogram mode: <ul style="list-style-type: none"> 3200 s (Time after arming)

*1: Typical values represent typical or average values. They are not strictly guaranteed.

*2: A value measured with the input coupling set to DC, input impedance set to 1 M Ω , under standard operating conditions as described in "General Specifications," and after the warm-up time has passed.

15.2 Measurement Functions (Measurement Items)

Item	Specification
Measurement update rate* ¹	400 ms (hardware histogram mode only) Update rate when measuring the period of a 1-MHz sine wave with the sampling size (number of events) set to 1000.
Frequency	<ul style="list-style-type: none"> Measurement range <ul style="list-style-type: none"> Time stamp mode: 8 ns to 20 ms Hardware histogram mode: 8 ns to 3.2 μs Display resolution <ul style="list-style-type: none"> Time stamp mode: 25ps Hardware histogram mode: Larger of the two values, 25 ps or (histogram X-axis span/600) Measurement resolution*¹ <ul style="list-style-type: none"> Time stamp mode: ± 100 ps rms $\pm \sqrt{2}$ x trigger error*² Hardware histogram mode: \pm(Larger of the two values, 100 ps rms or the display resolution) $\pm \sqrt{2}$ x trigger error*² Accuracy*¹ <ul style="list-style-type: none"> \pm measurement resolution \pm(time base frequency stability x measured value) ± 300 ps systematic error Slope: Select \uparrow or \downarrow
Time interval • AtoB interval	<ul style="list-style-type: none"> Measurement range <ul style="list-style-type: none"> Time stamp mode: 0 ns to 20 ms Hardware histogram mode: 0 ns to 3.2 μs Display resolution <ul style="list-style-type: none"> Time stamp mode: 25 ps Hardware histogram mode: Larger of the two values, 25ps or (histogram X-axis span/600) Measurement resolution*¹ <ul style="list-style-type: none"> Time stamp mode and <ul style="list-style-type: none"> the slope is $\mathbf{A \uparrow B \uparrow / A \uparrow B \downarrow / A \downarrow B \uparrow / A \downarrow B \downarrow}$: ± 100 ps rms $\pm A$ input trigger error *² $\pm B$ input trigger error*² the slope is $\mathbf{A \downarrow B \uparrow / A \downarrow B \downarrow}$: ± 100ps rms $\pm A$ input trigger error*² $\pm B$ input trigger error*² \pm trigger level timing error*³ Hardware histogram mode and <ul style="list-style-type: none"> the slope is $\mathbf{A \uparrow B \uparrow / A \uparrow B \downarrow / A \downarrow B \uparrow / A \downarrow B \downarrow}$: \pm(larger of the two values, 100 ps rms or display resolution) $\pm A$ input trigger error*² $\pm B$ input trigger error*² the slope is $\mathbf{A \downarrow B \uparrow / A \downarrow B \downarrow}$: \pm(larger of the two values, 100 ps rms or display resolution) $\pm A$ input trigger error*² $\pm B$ input trigger error*² \pm trigger level timing error*³ Accuracy*¹ <ul style="list-style-type: none"> \pm measurement resolution \pm(time base frequency stability x measured value) ± 1 ns systematic error Slope: Select from $\mathbf{A \uparrow B \uparrow / A \uparrow B \downarrow / A \downarrow B \uparrow / A \downarrow B \downarrow}$ Continuous measurement condition*¹: The time to the next edge of signal A after AtoB measurement is 13 ns or more and the time from the previous edge of signal A is 23 ns or more

Item	Specification
Pulse width	<ul style="list-style-type: none"> • Measurement range <ul style="list-style-type: none"> • Time stamp mode: 8 ns to 20 ms • Hardware histogram mode: 8 ns to 3.2 μs • Display resolution <ul style="list-style-type: none"> • Time stamp mode: 25 ps • Hardware histogram mode: Larger of the two values, 25 ps or (histogram X-axis span/600) • Measurement resolution*¹ <ul style="list-style-type: none"> • Time stamp mode and <ul style="list-style-type: none"> • the polarity is  or  : ±100 ps rms±rising trigger error*²±falling trigger error*² • the polarity is  : ±100 ps rms±rising trigger error*²±falling trigger error*²±trigger level timing error*³ • Hardware histogram mode and <ul style="list-style-type: none"> • the polarity is  or  : ±(Larger of the two values, 100 ps rms or the display resolution)±rising trigger error*² ±falling trigger error*² • the polarity is  : ±(Larger of the two values, 100 ps rms or the display resolution)±rising trigger error*² ±falling trigger error*²±trigger level timing error*³ • Accuracy*¹ <ul style="list-style-type: none"> ±Measurement resolution±(time base frequency stability x measured value)±1 ns systematic error • Polarity: Select from   

*1: A value measured under standard operating conditions as described in "General Specifications" after the warm-up time has passed.

*2: Trigger error, A input trigger error, B input trigger, rising trigger error, and falling trigger error are defined by the following equation

$$\frac{\sqrt{X^2 + E_n^2}}{S.R}$$

X : Input amplifier noise
 E_n : Noise on the measured signal
 S.R : Slew rate of the input signal (V/s)

*3: The trigger level timing error is defined by the following equation.

$$\pm \left(\frac{8 \text{ mV}}{\text{slew rate of the start signal}} - \frac{8 \text{ mV}}{\text{slew rate of the stop signal}} \right) \pm \frac{\text{trigger level setting accuracy}}{\text{slew rate of the start signal}} \pm \frac{\text{trigger level setting accuracy}}{\text{slew rate of the stop signal}}$$

15.3 Gate, Arming, and Inhibit

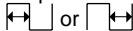
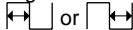







Item	Specification
External arming input (shared with the external gate)	<ul style="list-style-type: none"> • Connector type: BNC • Input coupling: DC • Input impedance: 1 MΩ (Typical value*¹) • Trigger level: TTL (1.4 V), TTL/10 (0.14 V), 0 V • Maximum input voltage: 40 V (DC+ACpeak) • Minimum input pulse width: 30 ns • Setup time: 50 ns (For the arming to become effective, the arming signal must arrive at least 50 ns earlier than the measurement signal.)
Inhibit input	<ul style="list-style-type: none"> • Connector type: BNC • Input coupling: DC • Input impedance: 1 MΩ (Typical value*¹) • Trigger level: TTL (1.4 V), TTL/10 (0.14 V), 0 V • Maximum input voltage: 40 V (DC+ACpeak) • Minimum input pulse width: 30 ns • Setup time: 50 ns (For the inhibit to become effective, the arming signal must arrive at least 50 ns earlier than the measurement signal.)
Gate	<ul style="list-style-type: none"> • Type: Select from EVENT, TIME, and EXTERNAL • Configurable number of events during event gate (except within the longest sampling time) <ul style="list-style-type: none"> • Time stamp mode: 1 to 512,000 • Hardware histogram mode: 1 to 10⁹, accuracy: ± 1 • Configurable gate time range during time gate (except within the maximum number of events of each sampling mode) <ul style="list-style-type: none"> 1 μs \leq gate time \leq 10 s (Resolution: 100 ns) • Allowable time during external gate <ul style="list-style-type: none"> 1 μs to 320 s (except within the maximum number of events of each sampling mode) • Polarity: Select 
Arming	<ul style="list-style-type: none"> • Arming source: Select AUTO or EXT • EXT settings <ul style="list-style-type: none"> • Delay time range during time delay <ul style="list-style-type: none"> 1 μs \leq delay time \leq 1 s (Resolution: 100 ns) • Range during event delay <ul style="list-style-type: none"> 1 to 10⁶ • Slope: Select \uparrow or \downarrow
Inhibit	<ul style="list-style-type: none"> • Effective time: 1 μs to 320 s (1 μs to 3,200 s when the sampling mode is set to other than 0 μs or the sampling mode is set to Hardware histogram mode) • Polarity: Select 

*1: Typical values represent typical or average values. They are not strictly guaranteed.

15.4 Block Sampling

Item	Specification
Range of number of blocks	Time stamp mode: 1 to 100 Hardware histogram mode: 1 to 1000 However, the number of samples that can be measured is determined by the maximum sampling size for each mode.
Block pause mode	Select OFF, Time, or Event
Block pause time	RestTime: OFF, 1 μ s to 1 s (Resolution 100 ns) RestEvent: OFF, 1 to 10 ⁶ (Resolution 1, Except the pause time is 500 ns or more and the frequency is 50 MHz or less)
Conditions on use	Cannot use this function together with the external gate or the inter-symbolic interference analysis function. Event gate must be two or more.

15.5 Display

Item	Specification
Display	<ul style="list-style-type: none"> • Size: 6.4 inch • Resolution: 640 (H)x 480 (V) dots • Defect: 0.01% or less with respect to the total number of pixels
Display format	<ul style="list-style-type: none"> • Time stamp mode: Select from histogram, list, time variation, and statistics • Hardware histogram mode: Select from histogram, list, and statistics
Histogram display, during time stamp mode	
	<ul style="list-style-type: none"> • Scale: X- and Y-axis settings of the histogram <ul style="list-style-type: none"> • X CENTER (center value of X-axis) range -50 ns to 20.000000000 ms • X Span Select from 1.5, 3, 7.5, 15, 30, 60, 150, 300, 600 ns, 1.5, 3, 6, 15, 30, 60, 150, 300, 600 μs, 1.5, 3, 6, 15, and 30 ms • Y Axis (Y-axis scale): Select Lin (linear) or Log (logarithmic) • Y High (Maximum value of Y-axis) <ul style="list-style-type: none"> • When the Y-axis scale is Lin: Select from 10, 20, 40, 100, 200, 400, 1000, 2000, 4000, 10000, 20000, 40000, 100000, 200000, 400000, $1e^6$, $1e^7$, $1e^8$, and $1e^9$ • When the Y-axis scale is Log: Select from 10^1, 10^2, 10^3, 10^4, 10^5, 10^6, 10^7, 10^8, and 10^9 • Readout: Values can be read by placing the X marker over the waveform (Marker display can be turned ON/OFF) <ul style="list-style-type: none"> Y marker: Statistical calculation area can be specified by setting the frequency (Marker display can be turned ON/OFF) • Statistical display (Can be turned ON/OFF) <ul style="list-style-type: none"> • Area: Select the area, Window or Marker, on which to calculate the statistics. Select the polarity, , , or  when measuring . Select the slope, A \uparrow B \uparrow, A \downarrow B \uparrow, or A \uparrow B \downarrow when measuring A \uparrow B \uparrow. Select the slope, A \uparrow B \downarrow, A \downarrow B \downarrow, or A \uparrow B \downarrow when measuring A \uparrow B \downarrow. • T Value: Set the T value of the statistical calculation Range: 1 ns to 250.000 ns
Histogram display, during hardware histogram mode	
	<ul style="list-style-type: none"> • Scale: X- and Y-axis settings of the histogram <ul style="list-style-type: none"> • X CENTER (center value of X-axis) range: -50 ns to 3.2 μs • X Span: Select from 1.5, 3, 7.5, 15, 30, 60, 150, 300, 600ns, 1.5, 3, and 6 μs • Y Axis (Y-axis scale): Select Lin (linear) or Log (logarithmic) • Y High (Maximum value of Y-axis) <ul style="list-style-type: none"> • When the Y-axis scale is Lin: Select from 10, 20, 40, 100, 200, 400, 1000, 2000, 4000, 10000, 20000, 40000, 100000, 200000, 400000, $1e^6$, $1e^7$, $1e^8$, and $1e^9$ • When the Y-axis scale is Log: Select from 10^1, 10^2, 10^3, 10^4, 10^5, 10^6, 10^7, 10^8, and 10^9 • Readout: Values can be read by placing the X marker over the waveform (Marker display can be turned ON/OFF) <ul style="list-style-type: none"> Y marker: Statistical calculation area can be specified by setting the frequency (Marker display can be turned ON/OFF) • Statistical display (Can be turned ON/OFF) <ul style="list-style-type: none"> • Area: Select the area, Window or Marker, on which to calculate the statistics. Select the polarity, , , or  when measuring . Select the slope, A \uparrow B \uparrow, A \downarrow B \uparrow, or A \uparrow B \downarrow when measuring A \uparrow B \uparrow. Select the slope, A \uparrow B \downarrow, A \downarrow B \downarrow, or A \uparrow B \downarrow when measuring A \uparrow B \downarrow. • T Value: Set the T value of the statistical calculation Range: 1 ns to 250.000 ns • Multi-window: The data of multiple histograms can be analyzed. Window size range: 1 to 16 • Auto window: The data of multiple histograms are analyzed automatically. • Panorama display: Enables the user to observe an overall view of the histograms <ul style="list-style-type: none"> • Panorama display can be turned ON/OFF • Panorama area selection: The range of 0 to 3.2 μs can be divided into eight sections • Histogram sum (for multi-window and auto window only) The center values of the X-axis of the histogram of each window are aligned and the frequencies of each bin are summed.

15.5 Display/15.6 Auto Window Function

Item	Specification
Time variation display (during time stamp mode only)	<ul style="list-style-type: none"> Scale: X- and Y-axis settings of time variation displays <ul style="list-style-type: none"> X Min (Minimum value of X-axis) range: 0 to 3200.0000000 s X Span (Maximum value of X-axis): Select from 6, 12, 30, 60, 120, 300, 600 μs, 1.2, 3, 6, 12, 30, 60, 120, 300, 600, 1200, 3000, 6000 s Y Center(Center value of Y-axis) range: -50 ns to 20.000000000 ms Y Span: Select from 500 ps, 1, 2.5, 5, 10, 20, 50, 100, 200, 500 ns, 1, 2, 5, 10, 20, 50, 100, 200, 500 μs, 1, 2, 5, 10, 20 ms Readout: Values can be read by placing the X and Y markers over the waveform Statistical display (Can be turned ON/OFF) <ul style="list-style-type: none"> Area: Select the area, Window, Marker, or Block, on which to calculate the statistics. Display parameter: Grid and interpolation display can be turned ON/OFF Plot marks can be set to Pixel or Mark Time resolution of X-axis (time stamp): 100 ns (When the sampling interval is other than 0 μs, it is 1 μs)
List display, during time stamp mode	<p>Lists the time stamps and the measured values at those times The list can be displayed for each block when block sampling is being used.</p> <ul style="list-style-type: none"> The displayed data can be scrolled. Resolution of time stamps: 100 ns (When the sampling interval is other than 0 μs, it is 1 μs)
List display, during hardware histogram mode	<p>Lists the measured values (histogram class values) and frequencies The displayed data can be scrolled.</p>
Statistics display, during time stamp mode	<p>When calculating statistics on a histogram Statistical parameters: Average, Maximum, Minimum, Peak-Peak, σ, σ/Average, σ/T, E.L.Error, MELE, Median, Mode, and Number</p> <p>When calculating statistics on time variation data Statistical parameters: T.Average, T.Maximum, T.Minimum, T.Peak-Peak, T.σ, T.σ/Average, T.(P-P/Average), T.RF, and T.Num</p>
Statistics display, during hardware histogram mode	<p>Statistical parameters: Average, Maximum, Minimum, Peak-Peak, σ, σ/Average, σ/T, E.L.Error, MELE, Median, Mode, and Number</p>

15.6 Auto Window Function

Item	Specification
Auto window function	A function in which the window size, scale, and area are automatically configured by measuring the T value and considering the modulation method.
Modulation method	EFM modulation, EFM+modulation, and 1-7 modulation
T Value calculation method	<p>Measured T: Automatically measure the value of the constant T from the clock input signal of CHB</p> <p>Estimated T: Estimate the value of the constant T from the input signal and the modulation method</p> <p>Operating conditions Measured T: CHB input 1025 cycles or more Estimated T: Data rate 43 MS/s or less, sampling rate 1.6 s or less</p>
T measurement range	8 ns to 250 ns
T resolution	Measured T: 12.8ps

15.7 Inter-symbol Interference Analysis Function (Option)

Item	Specification
Function	A function in which the data around the specified space or mark are extracted and the histogram and statistics of the data are displayed.
Measurement conditions	In the time stamp mode measuring the pulse width with the polarity set to 
Extraction mode	Select from Single, Combination, and Between
Trigger	Select mark or space
Target	Select the data to be analyzed for the trigger from Prev., Next, and Both

15.8 Rear Panel Input/Output

Item	Specification
Reference input	<ul style="list-style-type: none"> • Connector type: BNC • Input coupling: AC • Input impedance: 1 kΩ or more • Input frequency range: 10 MHz\pm10 Hz • Input level: 1 Vp-p or greater • Maximum input voltage: \pm10 V
Reference output	<ul style="list-style-type: none"> • Connector type: BNC • Output coupling: AC • Output impedance: 50 Ω (Typical value*¹) • Output frequency: 10 MHz (Typical value*¹) • Output level*²: 1 Vp-p or greater
Monitor output (CHA/CHB)	<ul style="list-style-type: none"> • Connector type: BNC • Output impedance: 50 Ω (Typical value*¹) • Output level*²: Approx. one-fourth of the input signal (\pm5 V or less)

*1: Typical values represent typical or average values. They are not strictly guaranteed.

*2: The level when the input impedance of the receiving side is 50 Ω .

15.9 GP-IB Interface

Item	Specification
Interface	GP-IB
Electrical and mechanical specifications	Conforms to IEEE St'd 488-1978(JIS C 1901-1987)
Functional specifications	SH1, AH1, T6, L4, SR1, RL1, PP0, DC1, DT1, C0
Protocol	Conforms to IEEE St'd 488.2-1992
Code	ISO (ASCII) code
Mode	Addressable mode
Address	0 to 30
Remote mode clear	The remote mode can be cleared by pressing the LOCAL (SHIFT+AUTO SCALE) key (except when Local Lockout is in effect)

15.10 SCSI (Option)

Item	Specification
Standard	SCSI(Small Computer System Interface).ANSIX3.131-1986
Connector	50-pin half pitch (pin type)
Connector pin assignments	Unbalanced (single-ended), built-in terminator
Compatible SCSI devices*	HD drive: NEC MS-DOS ver3.3 or later or SCSI HD drives that can be formatted with EZ-SCSI MO drive: 128, 230, and 640 MB drives, MO medium uses semi-IBM format. ZIP drive PD drive

*1 For details on which devices can be connected, ask your YOKOGAWA dealer.

15.11 Time Base

Item	Specification
Internal reference frequency (clock)	10-MHz temperature-compensated crystal oscillator
Frequency stability	Aging rate: ± 1.5 ppm/year Temperature characteristics: ± 2.5 ppm in the range from 5 to 40°C with 25°C as the reference
External adjustment	Possible

15.12 Internal Memory Function

Store and recall 10 sets of setup information in the nonvolatile memory.

15.13 Built-in Printer

Item	Specification
Printing format	Thermal line dot method
Dot density	8 dots/mm
Paper width	112 mm
Recording width	104 mm

15.14 Built-in Floppy Disk Drive

Item	Specification
Drive type	3.5-inch floppy disk
Number of drives	1
Format type	640 KB, 720 KB, 1.2 MB, 1.44 MB (MS-DOS compatible)

15.15 Internal Hard Disk Drive (Option)

Item	Specification
Number of drives	1
Capacity	3.2 GB (IBM format)

* The hard disk can be mounted on a PC (Windows 95 compatible)

15.16 General Specifications

Item	Specification															
Safety standard	Complies with EN61010-1 <ul style="list-style-type: none"> • Overvoltage category I and II • Pollution degree 1 and 2 															
Standard operating conditions	<ul style="list-style-type: none"> • Ambient temperature: 23±2°C • Ambient humidity: 50±10%RH • Power voltage and frequency error: Less than 1% of the ratings 															
Operating altitude	2000 m or less															
Warm-up time	Approx. 30 minutes															
Storage conditions	<ul style="list-style-type: none"> • Temperature: -20 to 60°C • Humidity: 20 to 80%RH (no condensation) 															
Operating conditions	<ul style="list-style-type: none"> • Temperature: 5 to 40°C • Humidity: 20 to 80%RH (no condensation) 															
Rated supply voltage	100 to 120 V AC (suffix code -1) 200 to 240 V AC (suffix code -5)															
Permitted supply voltage range	90 to 132 V AC (suffix code -1) 180 to 264 V AC (suffix code -5)															
Rated supply voltage frequency	50/60 Hz															
Permitted supply voltage frequency range	48 to 63 Hz															
Maximum power consumption	200 VA															
Withstand voltage (between power supply and case)	1.5 kV AC for one minute															
Insulation resistance (between power supply and case)	10 MΩ or more at 500 V DC															
Signal ground	All input/output connectors must be grounded to the case															
External dimensions	Approx. 213 (W)x266 (H)x350 (D) mm, excluding projections															
Weight	Approx. 10 kg (main unit only)															
Cooling method	Forced air cooling															
Installation position	Horizontal (no stacking of instruments)															
Battery backup	Setup and clock information are backed up by internal lithium batteries.															
Fuse*1	<table border="1"> <thead> <tr> <th>Location</th> <th>Maximum Rated Voltage</th> <th>Maximum Rated Current</th> <th>Type</th> <th>Standard</th> </tr> </thead> <tbody> <tr> <td>Inlet</td> <td>250 V</td> <td>3 A</td> <td>Time lag</td> <td>UL, CSA certified</td> </tr> <tr> <td>CPU board</td> <td>250 V</td> <td>800 mA</td> <td>Time lag</td> <td>VDE/SEMKO certified</td> </tr> </tbody> </table>	Location	Maximum Rated Voltage	Maximum Rated Current	Type	Standard	Inlet	250 V	3 A	Time lag	UL, CSA certified	CPU board	250 V	800 mA	Time lag	VDE/SEMKO certified
Location	Maximum Rated Voltage	Maximum Rated Current	Type	Standard												
Inlet	250 V	3 A	Time lag	UL, CSA certified												
CPU board	250 V	800 mA	Time lag	VDE/SEMKO certified												
Standard accessories	<ul style="list-style-type: none"> • Power cord 1 piece • Rubber feet: 2 pieces • 1 roll of printer paper • User's Manual 1 piece (this manual) • GP-IB Interface User's Manual 1 piece 															
Safety standard*2	Complying standard EN61010-1 Overvoltage Category (Installation Category)II*3 Pollution degree 2*4															
Emission*2	Complying standard EN55011-Group1 Class A This is a Class A product(for industrial environment). In a domestic environment this product may cause radio interference in which case the user may be required to take adequate measures.															

Item	Specification
Immunity*2	Complying standard EN61326-1:1995 <ul style="list-style-type: none"> • Cables condition The applied BNC cable, GP-IB cable and SCSI cable must be shorter than 3 meters.
*1	The user cannot replace the fuse that is located inside the case. If you believe the fuse inside the case is blown, contact your nearest YOKOGAWA dealer.
*2	Applies to products manufactured after Aug. 1999 having the CE Mark. For all other products, please contact your nearest YOKOGAWA representative.
*3	Overvoltage Categories define transient overvoltage levels, including impulse withstand voltage levels. Overvoltage Category I : Applies to equipment supplied with electricity from a circuit containing an overvoltage control device.
	Overvoltage Category II : Applies to equipment supplied with electricity from fixed installations like a distribution board.
*4	Pollution Degree : Applies to the degree of adhesion of a solid, liquid, or gas which deteriorates withstand voltage or surface resistivity.
	Pollution Degree 1 : Applies to closed atmospheres (with no, or only dry, non-conductive pollution).
	Pollution Degree 2 : Applies to normal indoor atmospheres (with only non-conductive pollution).

15.17 External Dimensions

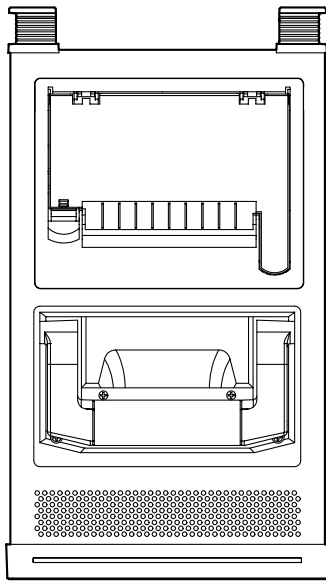

Rear View

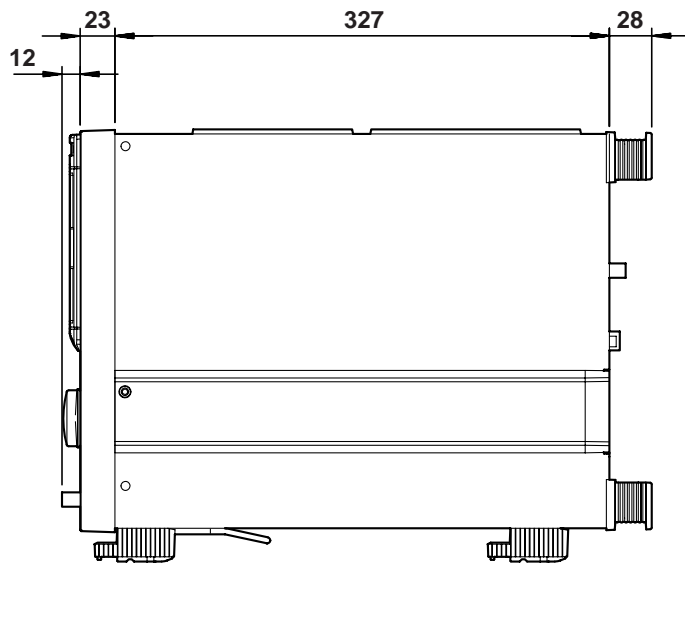
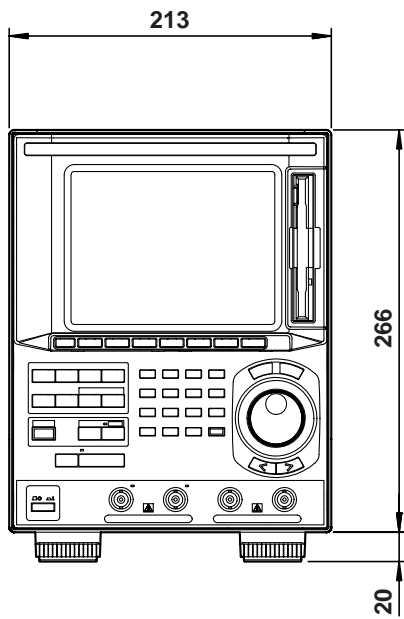
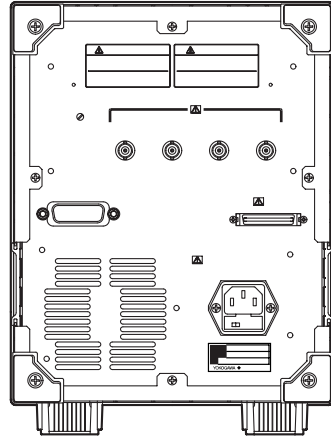

Unless specified otherwise, the tolerance is $\pm 3\%$. However, in cases of less than 10 mm, the tolerance is ± 0.3 mm.

Index

Symbols

1-7 8-14

A

Adjustment function 7-11, 8-9
Alert messages 14-2
Area 7-10
Area Max 8-8
Area Min 8-8
Arrow keys 4-3
Ascii 11-14
Auto Window 8-13
Auto naming 11-11
Auto scaling 7-16, 8-19
Auto window function 1-24
arming 1-9, 6-9
attribute 11-20
auto scaling 1-24

B

Between 9-5
Bin 11-14
Block Diagram 1-1
block number 7-4, 7-6
block sampling 1-7, 6-5
block size 6-6
brightness 13-8

C

Calculation Polarity 7-2, 7-14, 8-2, 8-17
Calculation Slope 7-2, 7-14, 8-2, 8-17
Calibration 1-26
Center value 2-4
Changing the file name 11-24
Combination 9-5
Connect 7-6
Copies the X-axis setting 8-15
Creates a directory 11-25
calculation area 7-13, 8-17
calculation polarity 7-14, 8-17
calibration 13-4
compression 12-8
connecting the power 3-5
copy 11-21

D

Data compression 12-8
Data size 11-11, 11-15, 11-17
Dot Type 7-6
data type 11-14
date 3-10
delete 11-18, 11-20
directory 11-11, 11-25

E

EFM 8-14
EFM+ 8-14
ESC key 4-4
Error Logging 1-26, 14-4
Error messages 14-2
Estimated T 1-24, 8-14
Event gate 1-8
External gate 1-8
extension 11-11, 11-14, 11-17
external arming input terminals 6-9
external gate input terminals 6-2
extracted data 9-5
extraction 9-5

F

Filter 11-11, 11-20
Floppy Disks 11-1
Frequency distribution 1-18
Front Panel 2-1
format 11-6, 11-7

G

Graph Parameter 7-6
Graph Size 7-2, 7-6, 8-2
Grid 7-6
gate 1-8, 6-2

H

HDD Motor 11-2
Half tone 12-8
Hardware histogram mode 1-4, 5-1
Histogram 1-18, 7-1, 8-1

I

ID number 11-4

Index

ISI 1-26, 9-2
Initial settings 13-2
Inter-symbol Interference Analysis Function 1-26, 9-1
Internal Memory 10-1
icon 2-3
inhibit 1-10, 6-12
inhibit input terminals 6-12
input coupling 1-11, 6-14
input impedance 1-11, 6-14

K

keyboard 4-2

L

LCD monitor 13-8
List 1-19, 7-3, 8-3
lithium battery 3-6
load 11-10, 11-13

M

MODEL ii
Manual scaling 1-24, 7-16, 8-19
Manual trigger 1-12
Maximum sampling size 15-1
Measured T 1-24, 8-14
Measurement Functions 1-5
Measurement channel 5-2, 5-6
Measurement range 5-2, 5-3, 5-6
Monitor output 1-25, 13-5
Multi-window function 1-23
main window 1-22
mark 9-5
marker 1-13, 7-19, 8-21
measurement block 1-6
measurement results 11-12
memory number 10-1
messages 14-2
modulation 8-14
movable holder 12-2
multi-window 1-23, 8-10

N

Normal 11-7
Num 1-13
Number 8-6
numerical keys 4-2

O

Output data format 12-8

Overlap 7-2, 8-2
optional accessories iii

P

Panorama display 1-22, 7-10, 8-8
Paper feed 12-5
Partition 11-7
Period Measurement 1-5, 5-2
Power Switch 3-6
Printing 12-4
Properties 11-11
Pulse Width Measurement 1-5, 5-5
panorama window 1-22
pause time 6-6
polarity 5-6, 6-12
position 7-10, 8-8
printer cover 12-3

Q

Quick 11-7

R

RESET key 4-4
ROM version 13-6
Rack mount 3-4
Readout Function 1-13
Rear Panel 2-2
Recalled 10-2
Reference Signal 6-15
Reference input 1-12, 1-25
Reference output 1-12, 1-25
Repeat auto trigger 1-12
RestEvent 6-6
RestTime 6-6
read out 7-19, 8-21
reference input terminal 6-15
release arm 12-2
roll paper 12-1, 12-2
rotary knob 4-2, 4-4

S

SCSI 11-3
SCSI ID number 11-4
SCSI devices 11-3
Scale Value 7-15, 8-18
Selecting the directory 11-8, 11-11
Self-test 1-26, 14-5
Setup Condition 13-6
Single 9-5
Single auto trigger 1-12

Soft key menu	2-4
Stat Item	7-8
Statistical calculation parameters	1-14
Statistical parameter	7-8, 7-13, 8-6, 8-17
Statistics	1-21, 7-7, 8-5
Stored	10-1
Style	7-2, 7-6, 7-8, 8-2, 8-6
Summation	8-12
Summation display	1-23
sampling interval	1-8, 6-4
sampling mode	1-4, 5-1
save	11-8, 11-12, 11-16
screen image	12-8
setup information	11-8
slope	5-2, 5-3
soft key menu	4-4
space	9-5
standard accessories	iii
start the measurement	4-1
statistical calculation	1-14
statistical calculation area	7-13, 8-17
stop the measurement	4-1

T

T.Num	1-13
Time Interval Measurement	1-5, 5-3
Time Variation	1-20, 7-5
Time gate	1-8
Time stamp mode	1-4, 5-1
Trigger Mode	1-12
time	3-10
trigger level	1-12, 6-14

U

Updating the window	8-11
---------------------------	------

W

Warning messages	14-2
WindowNum	8-12
warning display	13-8
window mode	8-11
window size	8-11

Z

zoom box	1-22, 2-4, 8-8
zoom span	7-10, 8-8